Low Voltage

Flameproof motors for explosive gas atmospheres



With expertise, and a comprehensive portfolio of products and life-cycle services, we help value-minded industrial customers improve their energy efficiency and productivity.

Low voltage flameproof motors for explosive atmospheres

04 - 05	General information
06 - 12	Technical data
13	Dimension drawings
14 - 15	Motors in brief



General Information

Introduction

The use of electrical motors in potentially explosive atmospheres is quite frequent these days. These motors have to be constructed in such a way that there is no risk of an explosion. An Explosion occurs when the following situations occur:

- presence of potentially explosive atmosphere
- existence of a source of ignition
- possibility of transmission of the explosion

Classification of Hazardous Environment

According to IS: 5572, Hazardous areas are classified in the following ways depending on the degree of probability of the presence of hazardous atmosphere.

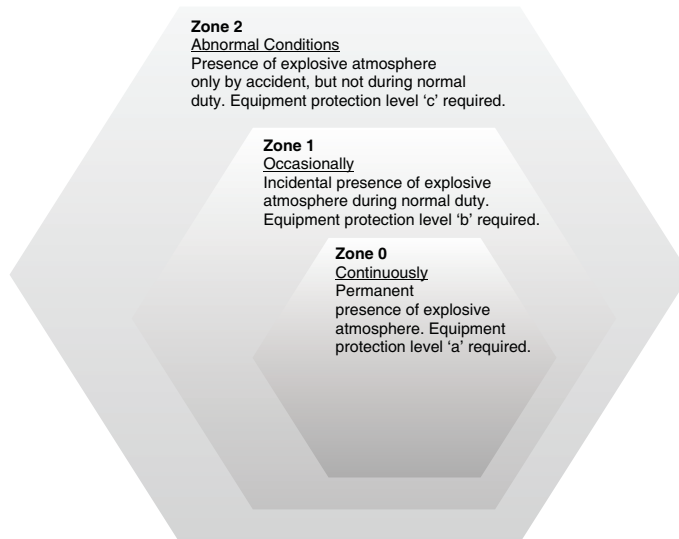

Zone Criteria presence of gas

Zone 0 Continuously or very long period

Zone 1 Present in normal operations

Zone 2 Unlikely, but if present, only for a short time

In Zone 0, no electrical motors can be installed. Most common motor for Zone 1 is the flameproof design, but it can also be used in Zone 2.

Application Groups

Depending on the intended use, explosion-proof electrical operating equipment is divided into two major groups:

Group I Equipment for coal mines (only specially designed motors for mines can be used)

Group II Electrical equipment for use other than mines (surface industry)

Group II motors with flameproof enclosures are still further divided into gas groups:

II A ~120 gases and vapors, e.g. butane / petroleum / propane

II B ~30 gases and vapors, e.g. ethylene / dimethyl ether

II C limited number of gases and vapors, e.g. hydrogen H₂ / acetylene C₂H₂ / carbon disulfide CS₂

Temperature Classes

Combustible gas or vapour and explosion-protected electrical equipment are divided into temperature of the gas up to T6 with regard to the ignition temperature of the gas or vapour and the maximum surface temperature of the component.

Temperature class	Ignition temperature for the gas / vapour °C	Maximum permitted temperature of electrical equipment °C
T1	>450	450
T2	>300 <450	300
T3	>200 <300	200
T4	>135 <200	135
T5	>100 <135	100
T6	>85 <100	15

Flame proof motors, type "db"

ABB motors of flame proof design (type M2JAP) are TEFC, 3 phase squirrel cage induction motor (as per IS/IEC 60079-1:2014) for operation in hazardous location classified as Zone 1 and Zone 2 areas as per IS:5572

The motor enclosure has been designed in such a way that no internal explosion can be transmitted to the explosive atmosphere surrounding the machine. The enclosure must withstand, without damage, any pressure levels caused by an internal explosion, the shape, length and gap of part assembly joints at shaft opening, cable entries, etc., shall be designed to allow for throttling and cooling of hot gases escaping outside. The standard emphasise the impact of an explosive atmosphere (for instance, explosion pressure) over constructional requirements of such apparatus.

Range: 0.18 kW to 55 kW

Frame: M2JAP 80 to 250 frame

Pole: 2 to 8 Pole

Features

- H Motors suitable for high ambient temperature 45°C.
- H Keeps an explosion which takes place inside the enclosure from propagating through gaps to the ambient.
- H Withstands the explosion pressure created inside the enclosures.
- H Benefits when dealing with special operating modes such as heavy starts and special applications.
- H All surface temperatures are selected to comply with the temperature class.
- H Suitability for use in temperature classes T1 to T4.
- H Can be used both in Zone 1 and Zone 2.

Technical data for Ex db IIB/IIC T4 Gb

IE2 Ex db cast iron motors, 3000 r/min

IP 55 - IC 411 - Insulation class F, temperature rise class B, Amb. 45 deg,

IE2 efficiency class according to IEC 60034-30-1:2014

Output KW	Motor Type	Product code	Speed r/min	Efficiency			Power factor cos ϕ	Current		Torque			Moment of inertia J=1/4GD ² kgm ²	Weight kg
				Full load 100%	3/4 load 75%	1/2 load 50%		I _n , A	I _s /I _n	T _n Nm	T _s /T _n	T _b /T _n		
3000 r/min = 2 poles			415V, 50Hz											
0.75	M2JAP80MB2	3GJA081320-CIN	2900	77.4	75.4	70.3	0.68	2.2	6.5	2.47	3.7	4.5	0.00082	45
1.1	M2JAP80MC2	3GJA081330-CIN	2880	81.8	81.6	79.1	0.77	2.33	7.7	3.63	3.7	3.7	0.00101	47
1.5	M2JAP90SLB2	3GJA091020-CIN	2905	83.4	83.6	81.7	0.86	2.84	7.5	4.92	2.9	3	0.00254	55
2.2	M2JAP90SLC2	3GJA091030-CIN	2878	83.2	83.9	82.3	0.87	4.3	6.5	7.3	2.6	3.1	0.0028	56
3.7	M2JAP100LC2	3GJA101530-CIN	2920	85.5	85.1	83	0.87	6.7	9	12.2	3	3.6	0.00728	75
5.5	M2JAP132SMB2	3GJA131220-CIN	2875	87	87.2	85.8	0.86	9.56	7.5	18.13	2.7	2.9	0.0128	102
7.5	M2JAP132SMC2	3GJA131230-CIN	2890	88.1	88.3	87	0.87	13.3	8.4	24.74	2.6	4.1	0.0136	104
9.3	M2JAP160MLJ2	3GJA161490-CIN	2931	88.9	89	87.9	0.89	16.4	7.1	30.3	2.8	3.4	0.043	213
11	M2JAP160MLA2	3GJA161410-CIN	2936	89.9	90.1	88.9	0.86	20	7.1	35.8	2.8	3.4	0.043	213
15	M2JAP160MLB2	3GJA161420-CIN	2934	91.1	91.1	90	0.86	26.9	7.6	48.8	3.1	3.6	0.052	222
18.5	M2JAP160MLC2	3GJA161430-CIN	2939	91.7	92.1	91.5	0.89	31.9	7.9	60.15	3.4	3.6	0.062	233
22	M2JAP180MLA2	3GJA181410-CIN	2943	92	92.4	92	0.89	38	7.4	71.3	2.7	3.5	0.089	265
30	M2JAP200MLA2	3GJA201410-CIN	2958	92.8	93.3	93	0.87	52.3	7.5	97.1	2.6	3.5	0.15	310
37	M2JAP200MLC2	3GJA201430-CIN	2958	93.6	93.9	93.4	0.88	63.1	8	119	2.5	3.3	0.19	340
45	M2JAP225SMB2	3GJA221220-CIN	2970	93.9	94	93.1	0.86	78.1	7.6	144	2.6	3.2	0.26	400
55	M2JAP250SMA2	3GJA251210-CIN	2977	94.2	94.2	93.2	0.86	94	7.7	176.7	2.2	3.3	0.49	460

Efficiency values are measured according to IEC 60034-2-1; 2007, IS 15999(Part 2 Sec 1):2011
Please note that the values are not comparable without knowing the testing method. ABB has calculated the efficiency values according to indirect method, stray load losses (additional losses) determined from measuring.

I_s / I_n = Starting current
T_s / T_n = Locked rotor torque
T_b / T_n = Breakdown

Technical data for Ex db IIB/IIC T4 Gb

IE2 Ex db cast iron motors, 1500 r/min

IP 55 - IC 411 - Insulation class F, temperature rise class B, Amb. 45 deg,

IE2 efficiency class according to IEC 60034-30-1:2014

Output KW	Motor Type	Product code	Speed r/min	Efficiency			Power factor cos ϕ	Current		Torque			Moment of inertia $J=1/4GD^2$ kgm ²	Weight kg
				Full load 100%	3/4 load 75%	1/2 load 50%		I_n , A	I_s/I_n	T_n Nm	T_s/T_n	T_b/T_n		
1500 r/min = 4 poles				415V, 50Hz										
0.55	M2JAP80MA4	3GJA082310-CIN	1445	77.1	75.9	70.9	0.66	1.52	6.4	3.62	3.6	3.7	0.00237	49
0.75	M2JAP80MD4	3GJA082340-CIN	1435	79.6	79	75.7	0.72	1.86	6	4.98	3.6	3.7	0.00287	40
1.1	M2JAP90SLB4	3GJA092020-CIN	1430	81.4	81.7	79.2	0.78	2.34	7.5	7.2	3.9	4.2	0.0039	55
1.5	M2JAP90SLD4	3GJA092040-CIN	1432	82.8	83	80.7	0.78	3.3	6.7	10	3.2	3.5	0.00437	58
2.2	M2JAP100LC4	3GJA102530-CIN	1450	84.3	83.7	80.3	0.75	4.98	7.8	14.5	3.5	4.3	0.00831	69
3.7	M2JAP112MB4	3GJA112320-CIN	1452	86.3	87.1	86.6	0.74	8	7.2	24.33	2.7	3.4	0.0188	81
5.5	M2JAP132SMB4	3GJA132220-CIN	1460	88.7	88.7	87	0.79	10.6	7.1	35.9	2.5	3.4	0.0296	107
7.5	M2JAP132SMC4	3GJA132230-CIN	1460	89	89.3	88	0.78	14.3	7.6	49.3	2.2	3.4	0.0327	110
9.3	M2JAP160MLJ4	3GJA162490-CIN	1460	89.3	89.8	89.3	0.81	17.9	8	60.83	2.7	3.4	0.088	232
11	M2JAP160MLC4	3GJA162430-CIN	1472	91.1	91.2	90.1	0.8	21.3	8.5	71.4	3.4	3.9	0.096	232
15	M2JAP160MLE4	3GJA162450-CIN	1470	92	92.3	91.6	0.82	27.8	8.4	97.52	3.6	3.5	0.13	255
18.5	M2JAP180MLA4	3GJA182410-CIN	1476	91.8	92.1	91.3	0.81	35	7.7	119.7	2.9	3.4	0.19	277
22	M2JAP180MLB4	3GJA182420-CIN	1476	92.2	92.3	91.4	0.8	41.7	8.2	142	3	3.6	0.23	296
30	M2JAP200MLB4	3GJA202420-CIN	1473	92.5	93.1	92.9	0.83	53.6	7.4	193	3	3	0.34	340
37	M2JAP225SMB4	3GJA222220-CIN	1482	93.6	93.5	92.4	0.83	67.2	7.6	238	3.1	3.2	0.42	390
45	M2JAP225SMC4	3GJA222230-CIN	1479	93.8	94.1	93.6	0.85	79.6	7	291	2.8	2.9	0.49	425
55	M2JAP250SMA4	3GJA252210-CIN	1480	94.5	94.8	94.4	0.83	98.8	7.5	355	2.7	3.3	0.72	415

Efficiency values are measured according to IEC 60034-2-1; 2007, IS 15999(Part2 Sec1):2011
 Please note that the values are not comparable without knowing the testing method. ABB has calculated the efficiency values according to indirect method, stray load losses (additional losses) determined from measuring.

I_s / I_n = Starting current
 T_s / T_n = Locked rotor torque
 T_b / T_n = Breakdown

Technical data for Ex db IIB/IIC T4 Gb

IE2 Ex db cast iron motors, 1000 r/min

IP 55 - IC 411 - Insulation class F, temperature rise class B, Amb. 45 deg,

IE2 efficiency class according to IEC 60034-30-1:2014

Output KW	Motor Type	Product code	Speed r/min	Efficiency			Power factor cos ϕ	Current		Torque			Moment of inertia J=1/4GD ² kgm ²	Weight kg
				Full load 100%	3/4 load 75%	1/2 load 50%		I _n , A	I _s /I _n	T _n Nm	T _s /T _n	T _b /T _n		
1000 r/min = 6 poles			415V, 50Hz											
0.25	M2JAP80MJ6	3GJA083390-CIN	941	61.6	58.9	50.9	0.6	0.79	2.6	2.52	1.6	2.1	0.0019	44
0.37	M2JAP80MA6	3GJA083310-CIN	930	67.6	67.4	62.8	0.65	1.11	4.3	3.8	2.5	2.7	0.00187	44
0.55	M2JAP80MB6	3GJA083320-CIN	925	73.1	73.9	70	0.69	1.53	3.9	5.6	2	2.4	0.00239	46
0.75	M2JAP90SLC6	3GJA093030-CIN	942	75.9	75.2	69.8	0.62	2.22	4	7.46	2.9	3.1	0.00392	56
1.1	M2JAP90SLE6	3GJA093050-CIN	940	78.2	78.1	74.5	0.64	2.9	3.9	11.1	2.1	2.5	0.006	59
1.5	M2JAP100L6	3GJA103500-CIN	955	81.4	81.5	79.3	0.68	3.72	4.4	15.04	1.6	2.9	0.00873	67
2.2	M2JAP112MC6	3GJA113330-CIN	952	84.2	85.5	84.9	0.7	5.1	4	21.67	1.3	1.9	0.0196	82
3.7	M2JAP132SMJ6	3GJA133290-CIN	960	84.3	84.3	81	0.69	8.8	7	36.8	1.6	2.2	0.0299	106
5.5	M2JAP132SMF6	3GJA133260-CIN	965	86	85.9	83.9	0.76	11.3	5.8	53.79	1.7	2.5	0.084	106
7.5	M2JAP160MLA6	3GJA163410-CIN	967	87.8	88.3	87.6	0.77	15.4	6.9	74.03	1.9	3.2	0.126	253
9.3	M2JAP160MLJ6	3GJA163490-CIN	970	88.1	88.4	87.2	0.77	21.6	7.4	90.08	2.6	3.5	0.116	253
11	M2JAP160MLB6	3GJA163420-CIN	974	90.1	90.7	89.8	0.79	21.6	7.4	108	2.5	3.9	0.126	253
15	M2JAP180MLB6	3GJA183420-CIN	975	89.8	90.3	89.3	0.8	29.3	7.2	147	2	3.3	0.25	304
18.5	M2JAP200MLA6	3GJA203410-CIN	984	91	91.2	90.2	0.8	35.6	6.7	179	2.6	3.3	0.37	300
22	M2JAP200MLB6	3GJA203420-CIN	984	91.6	91.8	91	0.81	42.3	7.8	213	3.5	3.5	0.43	320
30	M2JAP225SMB6	3GJA223220-CIN	986	92.2	92.4	91.6	0.81	57.3	7.8	290	3	3.2	0.64	385
37	M2JAP250SMA6	3GJA253210-CIN	991	92.2	92.5	91.8	0.81	68.9	6.7	357	2.8	3.3	1.16	455

Efficiency values are measured according to IEC 60034-2-1; 2007, IS 15999(Part 2 Sec 1):2011
Please note that the values are not comparable without knowing the testing method. ABB has calculated the efficiency values according to indirect method, stray load losses (additional losses) determined from measuring.

I_s / I_n = Starting current
T_s / T_n = Locked rotor torque
T_b / T_n = Breakdown

Technical data for Ex db IIB/IIC T4 Gb

IE2 Ex db cast iron motors, 750 r/min

IP 55 - IC 411 - Insulation class F, temperature rise class B, Amb. 45 deg,
IE2 efficiency class according to IEC 60034-30-1:2014

Output KW	Motor Type	Product code	Speed r/min	Efficiency			Power factor cos ϕ	Current		Torque			Moment of inertia J=1/4GD ² kgm ²	Weight kg
				Full load 100%	3/4 load 75%	1/2 load 50%		I _n , A	I _s /I _n	T _n Nm	T _s /T _n	T _b /T _n		
750 r/min = 8 poles			415V, 50Hz											
0.18	M2JAP80MA8	3GJA084310-CIN	685	45.9	44.5	36.8	0.57	0.72	3	2.5	2.1	2.6	0.0019	45
0.25	M2JAP80MB8	3GJA084320-CIN	690	50.6	50.4	44.6	0.59	0.97	3.1	3.47	2.1	2.4	0.0024	46
0.37	M2JAP90SLB8	3GJA094020-CIN	710	56.1	53.9	46.1	0.54	1.5	3	4.9	2	2.4	0.0044	55
0.55	M2JAP90SLC8	3GJA094030-CIN	680	61.7	62.6	58	0.57	2.11	2.7	7.72	1.6	1.9	0.0049	56
0.75	M2JAP100LA8	3GJA104510-CIN	710	72.5	70.9	65.7	0.56	2.56	3.7	10	1.9	2.8	0.0072	64
1.1	M2JAP100LB8	3GJA104520-CIN	705	74.9	74.5	70.8	0.61	3.18	3.5	14.8	1.7	2.4	0.00871	67
1.5	M2JAP112MC8	3GJA114330-CIN	713	79.6	80.7	79.7	0.63	4.1	3.8	19.8	1.4	2.2	0.0198	81
2.2	M2JAP132SMA8	3GJA134210-CIN	720	77.6	76.5	73	0.59	6.69	4.8	29.1	1.7	3	0.0299	106
3.7	M2JAP160MLJ8	3GJA164490-CIN	723	81.4	81.4	79.5	0.67	9.5	6	48.8	1.7	2.7	0.133	251
5.5	M2JAP160MLB8	3GJA164420-CIN	725	86.3	86.5	85	0.69	13.6	6.1	72.5	2	3.4	0.133	251
7.5	M2JAP160MLC8	3GJA164430-CIN	721	85.3	85.3	83.5	0.67	19	6	99.4	1.8	3.1	0.133	251
9.3	M2JAP180MLJ8	3GJA184490-CIN	725	86.3	86.3	83.6	0.62	21.6	5.9	122.5	2.1	2.9	0.226	298
11	M2JAP180MLB8	3GJA184420-CIN	725	88.4	88.4	86.9	0.7	25.3	6.1	145.5	2.2	3.3	0.245	298
15	M2JAP200MLA8	3GJA204410-CIN	735	90	89.4	88.3	0.77	30.2	7.2	194	2.4	3.5	0.45	315
18.5	M2JAP225SMA8	3GJA224210-CIN	735	90	90.1	88.7	0.72	40.2	6.1	240	1.9	3.3	0.61	370
22	M2JAP225SMB8	3GJA224220-CIN	733	90.7	91	90.1	0.75	45	6.8	286	2.1	3.1	0.68	350
30	M2JAP250SMA8	3GJA254210-CIN	736	91.7	91.9	90.9	0.77	60	7	389	2.2	3.1	1.25	420

Efficiency values are measured according to IEC 60034-2-1; 2007, IS 15999(Part2 Sec1):2011
Please note that the values are not comparable without knowing the testing method. ABB has calculated the efficiency values according to indirect method, stray load losses (additional losses) determined from measuring.

I_s / I_n = Starting current
T_s / T_n = Locked rotor torque
T_b / T_n = Breakdown

Technical data for Ex db IIB/IIC T4 Gb

IE3 Ex db cast iron motors, 3000 r/min

IP 55 - IC 411 - Insulation class F, temperature rise class B, Amb. 45 deg,

IE2 efficiency class according to IEC 60034-30-1:2014

Output KW	Motor Type	Product code	Speed r/min	Efficiency			Power factor cos ϕ	Current		Torque			Moment of inertia J=1/4GD ² kgm ²	Weight kg
				Full load 100%	3/4 load 75%	1/2 load 50%		I _n , A	I _s /I _n	T _n Nm	T _s /T _n	T _b /T _n		
3000 r/min = 2 poles			415V, 50Hz											
0.75	M2JAP80MD2	3GJA081340-DIN	2872	80.7	81.6	80.3	0.86	1.58	7.6	2.39	3.3	4	0.0012	49
1.1	M2JAP80MG2	3GJA081370-DIN	2870	82.7	83.2	81.9	0.84	2.31	7.4	3.65	3.3	3.8	0.00121	49
1.5	M2JAP90SLB2	3GJA091020-DIN	2897	84.2	85.8	85.2	0.89	2.83	8	4.94	3.5	3.9	0.0031	60
2.2	M2JAP90LC2	3GJA091530-DIN	2908	85.9	86.4	85.1	0.89	3.9	8.4	7.27	3.4	3.8	0.0044	63
3.7	M2JAP100LKB2	3GJA101820-DIN	2900	87.8	87.6	87	0.89	6.6	9	12.2	2.7	2.9	0.0086	75
5.5	M2JAP132SMF2	3GJA131260-DIN	2909	90.8	91.4	90.8	0.9	9.3	7.8	18.2	2.9	4.5	0.0218	124
7.5	M2JAP132SMG2	3GJA131270-DIN	2914	91.6	92.3	92.1	0.9	12.6	8.7	24.7	3.5	5	0.0218	124
9.3	M2JAP160MLJ2	3GJA161490-DIN	2946	90.7	91	90.2	0.9	15.9	7.7	30.14	2.7	3.7	0.0513	213
11	M2JAP160MLA2	3GJA161410-DIN	2946	91.2	91.8	91.3	0.9	18.5	7.7	35.52	2.8	3.9	0.057	225
15	M2JAP160MLB2	3GJA161420-DIN	2960	91.9	92	91.4	0.86	26.2	8.7	48.54	3.1	4.1	0.063	232
18.5	M2JAP160MLC2	3GJA161430-DIN	2952	92.4	92.9	92.3	0.89	31.1	9.6	59.74	3.6	4.2	0.076	246
22	M2JAP180MLA2	3GJA181410-DIN	2959	92.7	93.1	92.5	0.89	36.7	8.4	70.91	3.6	4.1	0.11	282
30	M2JAP200MLA2	3GJA201410-DIN	2961	93.3	93.6	93.3	0.87	51.1	8.1	96.8	2.8	3.3	0.182	332
37	M2JAP200MLB2	3GJA201420-DIN	2963	93.7	94.1	93.9	0.88	62.1	8.8	119.37	3.3	3.6	0.222	359
45	M2JAP225SMA2	3GJA221210-DIN	2970	94	93.9	92.9	0.85	78.3	7.7	144.69	2.7	3.3	0.296	405
55	M2JAP250SMA2	3GJA251210-DIN	2970	94.3	94.1	93.5	0.89	92.1	7.3	177	2.5	3.1	0.426	470

Efficiency values are measured according to IEC 60034-2-1; 2007, IS 15999(Part2 Sec1):2011
Please note that the values are not comparable without knowing the testing method. ABB has calculated the efficiency values according to indirect method, stray load losses (additional losses) determined from measuring.

I_s / I_n = Starting current
T_s / T_n = Locked rotor torque
T_b / T_n = Breakdown

Technical data for Ex db IIB/IIC T4 Gb

IE3 Ex db cast iron motors, 1500 r/min

IP 55 - IC 411 - Insulation class F, temperature rise class B, Amb. 45 deg,

IE2 efficiency class according to IEC 60034-30-1:2014

Output KW	Motor Type	Product code	Speed r/min	Efficiency			Power factor cos ϕ	Current		Torque			Moment of inertia J=1/4GD ² kgm ²	Weight kg
				Full load 100%	3/4 load 75%	1/2 load 50%		I _n , A	I _s /I _n	T _n Nm	T _s /T _n	T _b /T _n		
1500 r/min = 4 poles				415V, 50Hz										
0.55	M2JAP80MLD4	3GJA082440-DIN	1444	83.3	84.1	83	0.79	1.16	6.6	3.6	2.9	3.5	0.0028	49
0.75	M2JAP80MLG4	3GJA082470-DIN	1445	82.5	82.5	79.9	0.77	1.72	7	4.94	2.8	3.4	0.0033	50
1.1	M2JAP90SLC4	3GJA092030-DIN	1440	84.1	83.9	81.7	0.78	2.34	7.6	7.25	3.9	4.2	0.0067	61
1.5	M2JAP90LD4	3GJA092540-DIN	1446	85.3	86.0	85.0	0.76	3.1	8.2	9.95	3.6	4.8	0.0072	62
2.2	M2JAP100LKA4	3GJA102810-DIN	1455	86.7	86.9	85.5	0.84	4.22	8	14.4	3.5	4.3	0.0146	79
3.7	M2JAP112MF4	3GJA112360-DIN	1458	88.4	88.7	87.8	0.76	7.7	7.9	26.16	2.6	3.3	0.0188	81
5.5	M2JAP132SMF4	3GJA132260-DIN	1462	89.6	89.9	88.8	0.82	10.6	7.3	35.79	2.1	3.4	0.0401	119
7.5	M2JAP132SMG4	3GJA132270-DIN	1460	90.4	90.9	90.2	0.82	14.4	7.3	49	2.2	3.3	0.0401	119
9.3	M2JAP160MLJ4	3GJA162490-DIN	1470	91	90.6	89.1	0.81	17.6	8.2	60.4	2.9	3.6	0.0992	240
11	M2JAP160MLA4	3GJA162410-DIN	1479	91.4	91.6	90.7	0.81	20.5	8.2	71.2	2.9	3.6	0.11	240
15	M2JAP160MLB4	3GJA162420-DIN	1478	92.1	92.1	91.1	0.81	27.3	8.8	96.87	3.3	4	0.135	259
18.5	M2JAP180MLA4	3GJA182410-DIN	1482	92.6	93.1	92.6	0.82	33.8	7.8	119.17	3.1	3.3	0.219	291
22	M2JAP180MLB4	3GJA182420-DIN	1482	93.4	94	93.8	0.8	40.9	8.6	141	3	3.3	0.217	296
30	M2JAP200MLA4	3GJA202410-DIN	1485	93.6	93.8	93.1	0.83	53.6	8	193	2.9	3.5	0.385	360
37	M2JAP225SMA4	3GJA222210-DIN	1483	93.9	93.9	93.4	0.81	67.7	7.6	238.38	3.4	3.4	0.427	394
45	M2JAP225SMB4	3GJA222220-DIN	1483	94.2	94.3	93.8	0.82	81	8.6	290	3.5	3.8	0.525	431
55	M2JAP250SMA4	3GJA252210-DIN	1484	94.6	94.5	93.7	0.82	98.6	7.5	354	3.2	3.6	0.694	442

Efficiency values are measured according to IEC 60034-2-1; 2007, IS 15999(Part2 Sec1):2011
 Please note that the values are not comparable without knowing the testing method. ABB has calculated the efficiency values according to indirect method, stray load losses (additional losses) determined from measuring.

I_s / I_n = Starting current
 T_s / T_n = Locked rotor torque
 T_b / T_n = Breakdown

Technical data for Ex db IIB/IIC T4 Gb

IE3 Ex db cast iron motors, 1000 r/min

IP 55 - IC 411 - Insulation class F, temperature rise class B, Amb. 45 deg,

IE2 efficiency class according to IEC 60034-30-1:2014

Output KW	Motor Type	Product code	Speed r/min	Efficiency			Power factor cos ϕ	Current		Torque			Moment of inertia $J=1/4GD^2$ kgm ²	Weight kg
				Full load 100%	3/4 load 75%	1/2 load 50%		I_n , A	I_s/I_n	T_n Nm	T_s/T_n	T_b/T_n		
1000 r/min = 6 poles				415V, 50Hz										
0.25	M2JAP80MA6	3GJA083310-DIN	941	72.6	70.7	65	0.6	0.79	2.6	2.52	1.5	2.1	0.0019	44
0.37	M2JAP80MD6	3GJA083340-DIN	935	74.4	74.7	71.6	0.68	1	4.7	3.75	3	3.5	0.0028	47
0.55	M2JAP80MLG6	3GJA083470-DIN	941	80.6	80.7	78.6	0.6	1.58	4.6	5.6	2	2.4	0.0044	51
0.75	M2JAP90SLD6	3GJA093040-DIN	945	78.9	79.8	78.2	0.73	1.7	4.7	7.57	2.3	3	0.0056	58
1.1	M2JAP90LF6	3GJA093560-DIN	949	81	82.4	81.8	0.73	2.5	5	11.1	2.3	3.1	0.0068	61
1.5	M2JAP100LE6	3GJA103550-DIN	963	82.5	82.7	80.8	0.65	3.8	5.7	14.9	3	3.7	0.012	74
2.2	M2JAP112MJ6	3GJA113390-DIN	964	84.3	84.2	82	0.66	5.3	6.2	21.8	2.5	3.6	0.0196	82
3.7	M2JAP132SMJ6	3GJA133290-DIN	975	86.5	86.7	86	0.68	8.8	7.5	36.2	1.9	2.7	0.0416	106
5.5	M2JAP132SMH6	3GJA133280-DIN	968	88	88.6	88	0.63	13.5	5.2	54.1	2	2.9	0.0654	118
7.5	M2JAP160MLA6	3GJA163410-DIN	976	89.1	89.7	89.4	0.76	15.4	6.1	73.1	1.5	3.3	0.089	225
9.3	M2JAP160MLJ6	3GJA163490-DIN	970	89.8	90.1	89.3	0.77	18.7	7.1	91.08	2.1	3	0.128	259
11	M2JAP160MLB6	3GJA163420-DIN	977	90.3	91	90.6	0.77	22	6.9	107.29	1.8	3.4	0.138	259
15	M2JAP180MLA6	3GJA183410-DIN	980	91.2	91.7	91.1	0.77	29.6	5.5	146.7	1.7	2.9	0.212	288
18.5	M2JAP200MLA6	3GJA203410-DIN	990	91.7	91.8	90.9	0.81	34.5	7.8	178.6	2.8	3.5	0.496	340
22	M2JAP200MLB6	3GJA203420-DIN	990	92.2	92.2	91	0.79	41.9	7.8	212.2	2.9	3.8	0.585	367
30	M2JAP225SMA6	3GJA223210-DIN	989	92.9	92.6	91	0.73	61.8	8	290.6	3.1	3.7	0.724	419
37	M2JAP250SMA6	3GJA253210-DIN	990	93.3	93.6	93.2	0.79	69.8	7	357	2.6	3.4	1.3	503

Efficiency values are measured according to IEC 60034-2-1; 2007, IS 15999(Part2 Sec1):2011
Please note that the values are not comparable without knowing the testing method. ABB has calculated the efficiency values according to indirect method, stray load losses (additional losses) determined from measuring.

I_s / I_n = Starting current
 T_s / T_n = Locked rotor torque
 T_b / T_n = Breakdown

Dimension drawings

Flameproof motors, Ex db, Sizes 80 - 250

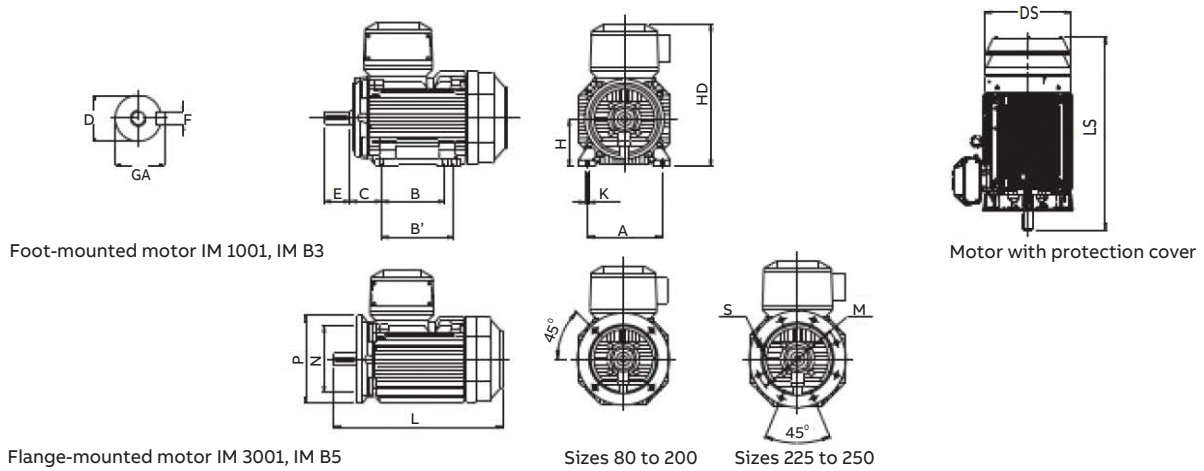

Foot-mounted motor IM 1001, IM B3

Motor with protection cover

Flange-mounted motor IM 3001, IM B5

Sizes 80 to 200

Sizes 225 to 250

Flameproof motors Ex db, foot-mounted IM 1001 / IM B3, flange-mounted IM 3001 / IM B5.

Motor size	IM 1001, IM B3 AND IM 3001, IM B5										IM 1001, IM B3					IM 3001, IM B5					Protective roof				
	D poles		GA poles		F poles		E poles		L max poles		O ¹⁾	A	B	B'	C	HD	K	H	M	N	P	S	DS	LS poles	
	2	4-8	2	4-8	2	4-8	2	4-8	2	4-8													2	4-8	
80	19	19	21.5	21.5	6	6	40	40	409	409	20	125	100	112	50	296	10	80	165	130	200	12	157	444	444
90	24	24	27	27	8	8	50	50	440	440	20	140	100	125	56	315	10	90	165	130	200	12	185	475	475
100	28	28	31	31	8	8	60	60	501	501	25	160	140	160	63	343	12	100	215	180	250	14.5	200	536	536
112	28	28	31	31	8	8	60	60	485	485	25	190	140	-	70	355	12	112	215	180	250	14.5	213	526	526
132	38	38	41	41	10	10	80	80	531 ⁽³⁾	531 ⁽³⁾	30	216	140	178	89	392	12	132	265	230	300	14.5	274	582	582
132 ²⁾	38	38	41	41	10	10	80	80	576	576	30	216	140	178	89	392	12	132	265	230	300	14.5	274	627	627
160	42	42	45	45	12	12	110	110	808	808	45	254	210	254	108	495	14.5	160	300	250	350	18.5	328	852	852
180	48	48	51.5	51.5	14	14	110	110	826	826	50	279	241	279	121	535	14.5	180	300	250	350	18.5	359	876	876
200	55	55	59	59	16	16	110	110	774	774	70	318	267	305	133	616	18.5	200	350	300	400	18.5	414	844	844
200 ²⁾	55	55	59	59	16	16	110	110	824	824	70	318	267	305	133	616	18.5	200	350	300	400	18.5	414	844	844
225	55	60	59	64	16	18	110	140	841	871	80	356	286	311	149	663	18.5	225	400	350	450	18.5	462	921	951
225 ²⁾	55	60	59	64	16	18	110	140	871	901	80	356	286	311	149	663	18.5	225	400	350	450	18.5	462	921	951
250	60	65	64	69	18	18	140	140	875	875	90	406	311	349	168	726	24	250	500	450	550	18.5	506	965	965
250 ²⁾	60	65	64	69	18	18	140	140	895	895	90	406	311	349	168	726	24	250	500	450	550	18.5	506	965	965

¹⁾ Required distance from fan cover air inlet to obstacle behind motor

²⁾ For IE3 version

³⁾ 576 for M2JAPSMF6

Available B14 and B5 flange alternatives

Flange size	Motor Size	Flange dimension			
		P	M	N	S
Ft100	80	120	100	80	M6
Ft115	90	140	115	95	M8
Ft130	100/112	160	130	110	M8
Ft165	132	200	165	130	M10

Above table gives the main dimensions in mm

Motors in brief

Flameproof motors Ex db, Sizes 80-180

Motor size		80	90	100	112	132	160	180
Stator	Material	Cast iron, EN-GJL-200 or better						
	Paint color shade	Blue, Munsell 8B 4.5/3.25						
	Corrosion class	C3						
Feet		Cast iron, EN-GJL-200 or better, integrated with stator						
Bearing end shields	Material	Cast iron, EN-GJL-200 or better						
	Paint colour shade	Blue, Munsell 8B 4.5/3.25						
	Corrosion class	C3						
Bearings	D-end 2-12 poles	6205-2Z/C3	6205-2Z/C3	6206-2Z/C3	6206-2Z/C	6208-2Z/C3	6309/C3	6310/C3
	N-end 2-12 poles	6204-2Z/C3	6204-2Z/C3	6205-2Z/C3	6206-2Z/C3	6208-2Z/C3	6309/C3	6310/C3
Axially locked bearings	Inner bearing cover	As standard, locked at D-end						
Bearing seals		Gamma ring						
Lubrication		Permanent grease lubrication						Regreasable bearings
SPM nipples		-						As option
Rating plate	Material	Stainless steel						
Terminal box	Frame material	Cast iron, EN-GJL-200 or better						
	Cover material	Cast iron, EN-GJL-200 or better						
	Cover screws material	Steel 8.8, zinc electroplated and chromated						
Connections	Cable entries	1 x M25		2 x M32		2 x M40		
	Terminals	6 terminals for connection with cable lugs (not included)						
Fan	Material	Polypropylene. Reinforced with glass fibre.						
Fan cover	Material	Steel						
	Paint color shade	Munsell blue 8B 4.5/3.25						
	Corrosion class	C3						
Stator winding	Material	Copper						
	Insulation	Insulation class F						
	Winding protection	3 pcs thermistors as option						
Rotor winding	Material	Pressure die-cast aluminum						
Balancing		Half-key balancing						
Keyway		Closed						
Heating elements	On request	25 W						
Drain holes		-						Optional
External earthing bolt		As standard						
Enclosure		IP 55						
Cooling method		IC 411						

Motors in brief

Flameproof motors Ex db, Sizes 200-250

Motor size		200	225	250
Stator	Material	Cast iron, EN-GJL-200 or better		
	Paint color shade	Munsell blue 8B 4.5/3.25		
	Corrosion class	C3		
Feet	Material	Cast iron, EN-GJL-200 or better, integrated with stator		
Bearing end shields	Material	Cast iron, EN-GJL-200 or better		
	Paint colour shade	Blue, Munsell 8B 4.5/3.25		
	Corrosion class	C3		
Bearings	D-end 2-8 pole	6312-2Z/C3	6313-2Z/C3	6315-2Z/C3
	N-end 2-8 pole	6310-2Z/C3	6312-2Z/C3	6313-2Z/C3
Axially locked Inner bearing cover bearings		As standard, locked at D-end		
Bearing seals		Gamma ring		
Lubrication		Permanent grease lubrication		
SPM nipples		As option		
Rating plate	Material	Stainless steel		
Terminal box	Frame material	Cast iron, EN-GJL-200 or better		
	Cover material	Cast iron, EN-GJL-200 or better		
	Cover screws material	Steel 8.8, zinc electroplated and chromated		
Connections	Cable-entries	2 x M50		
	Terminals	6 terminals for connection with cable lugs (not included)		
Fan	Material	Polypropylene. Reinforced with glass fibre.		
Fan cover	Material	Steel		
	Paint color shade	Munsell blue 8B 4.5/3.25		
	Corrosion class	C3		
Stator winding	Material	Copper		
	Insulation	Insulation class F		
	Winding protection	3 pcs thermistors as option		
Rotor winding	Material	Pressure die-cast aluminum		
Balancing		Half key balancing		
Keyway		Closed		
Heating elements	On request	25 W	60 W	60 W
Drain holes		Optional		
External earthing bolt		As standard		
Enclosure		IP 55		
Cooling method		IC 411		

ABB India Limited

32, Industrial Area,
N.I.T., Faridabad - 121 001
Tel: +91 129 2448100

www.abb.co.in

We reserve the right to make technical changes or modify the contents of this document without prior notice. With regard to purchase orders, the agreed particulars shall prevail. ABB does not accept any responsibility whatsoever for potential errors or possible lack of information in this document.

We reserve all rights in this document and in the subject matter and illustrations contained therein. Any reproduction, disclosure to third parties or utilization of its content - in whole or in parts - is forbidden without ABB's prior written consent.

11/2021

