

Technical Information

Omnigrad S TR63, TC63

Modular thermometer with thermowell and extension neck

TR63 Resistance thermometer (RTD)
TC63 Thermometer with thermocouple (TC)



Application

- Heavy duty applications
- Oil & Gas processing industry
- Measuring range:
 - TR63 with resistance insert (RTD): -200 to 600 °C (-328 to 1 112 °F)
 - TC63 with thermocouple (TC): -40 to 1 100 °C (-40 to 2 012 °F)
- Static pressure range up to 100 bar dependent on the used process connection
- Protection class: IP66/68

Head transmitter

All Endress+Hauser transmitters are available with enhanced accuracy and reliability compared to directly wired sensors. Easy customizing by choosing one of the following outputs and communication protocols:

- Analog output 4 to 20 mA
- HART®
- PROFIBUS® PA
- FOUNDATION Fieldbus™

Your benefits

- High degree of flexibility thanks to modular design with standard terminal heads as per DIN EN 50446 and customer-specific immersion lengths
- High degree of insert compatibility and design as per DIN 43772
- Extension neck, nipple union version, to protect the head transmitter from overheating
- Variable selection of process connections: thread, compression fitting or flange
- Optionally fast response time with tapered tip form
- Types of protection for use in hazardous locations:
 - Intrinsic Safety (Ex ia)
 - Flameproof (Ex d)
 - Non-sparking (Ex nA)

Function and system design

Measuring principle

Resistance thermometer (RTD)

These resistance thermometers use a Pt100 temperature sensor according to IEC 60751. The temperature sensor is a temperature-sensitive platinum resistor with a resistance of 100 Ω at 0 °C (32 °F) and a temperature coefficient $\alpha = 0.003851 \text{ } ^\circ\text{C}^{-1}$.

There are generally two different kinds of platinum resistance thermometers:

- **Wire wound (WW):** Here, a double coil of fine, high-purity platinum wire is located in a ceramic support. This is then sealed top and bottom with a ceramic protective layer. Such resistance thermometers not only facilitate very reproducible measurements but also offer good long-term stability of the resistance/temperature characteristic within temperature ranges up to 600 °C (1 112 °F). This type of sensor is relatively large in size and it is comparatively sensitive to vibrations.
- **Thin film platinum resistance thermometers (TF):** A very thin, ultrapure platinum layer, approx. 1 μm thick, is vaporized in a vacuum on a ceramic substrate and then structured photolithographically. The platinum conductor paths formed in this way create the measuring resistance. Additional covering and passivation layers are applied and reliably protect the thin platinum layer from contamination and oxidation, even at high temperatures.

The primary advantages of thin film temperature sensors over wire wound versions are their smaller sizes and better vibration resistance. A relatively low principle-based deviation of the resistance/temperature characteristic from the standard characteristic of IEC 60751 can frequently be observed among TF sensors at high temperatures. As a result, the tight limit values of tolerance category A as per IEC 60751 can only be observed with TF sensors at temperatures up to approx. 300 °C (572 °F). For this reason, thin-film sensors are generally only used for temperature measurements in ranges below 400 °C (932 °F).

Thermocouples (TC)

Thermocouples are comparatively simple, robust temperature sensors which use the Seebeck effect for temperature measurement: if two electrical conductors made of different materials are connected at a point, a weak electrical voltage can be measured between the two open conductor ends if the conductors are subjected to a thermal gradient. This voltage is called thermoelectric voltage or electromotive force (emf.). Its magnitude depends on the type of conducting materials and the temperature difference between the "measuring point" (the junction of the two conductors) and the "cold junction" (the open conductor ends). Accordingly, thermocouples primarily only measure differences in temperature. The absolute temperature at the measuring point can be determined from these if the associated temperature at the cold junction is known or is measured separately and compensated for. The material combinations and associated thermoelectric voltage/temperature characteristics of the most common types of thermocouple are standardized in the IEC 60584 and ASTM E230/ANSI MC96.1 standards.

Measuring system

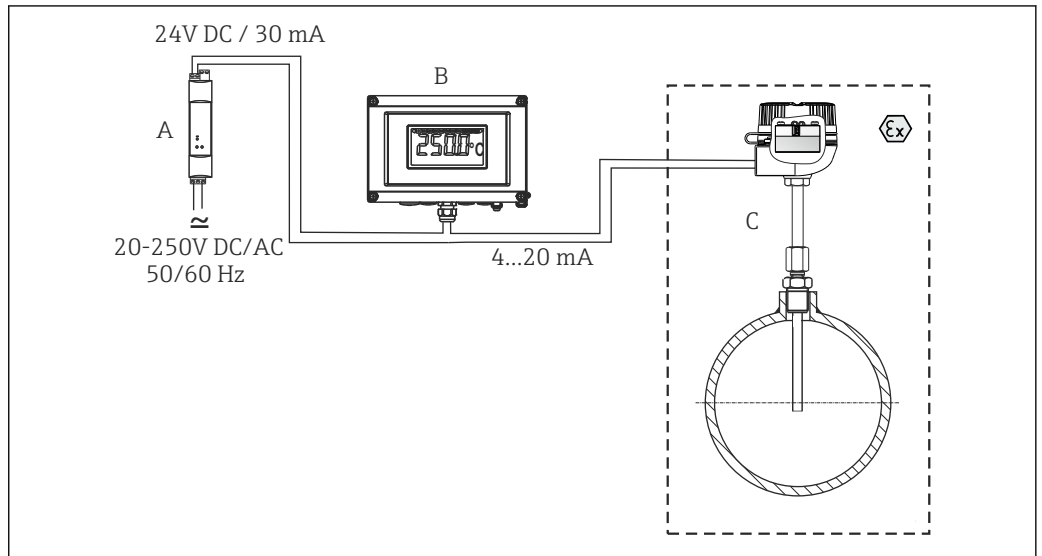

A0017701

- A Active barrier RN221N - The RN221N (24 V DC, 30 mA) active barrier has a galvanically isolated output for supplying voltage to loop-powered transmitters. The universal power supply works with an input supply voltage of 20 to 250 V DC/AC, 50/60 Hz, which means that it can be used in all international power grids. More information on this can be found in the Technical Information (see "Documentation").
- B RIA16 field display unit - The display unit records the analog measuring signal from the head transmitter and shows this on the display. The LC display shows the current measured value in digital form and as a bar graph indicating a limit value violation. The display unit is looped into the 4 to 20 mA circuit and gets the required energy from there. More information on this can be found in the Technical Information (see "Documentation").
- C Mounted thermometer with head transmitter installed.

Design

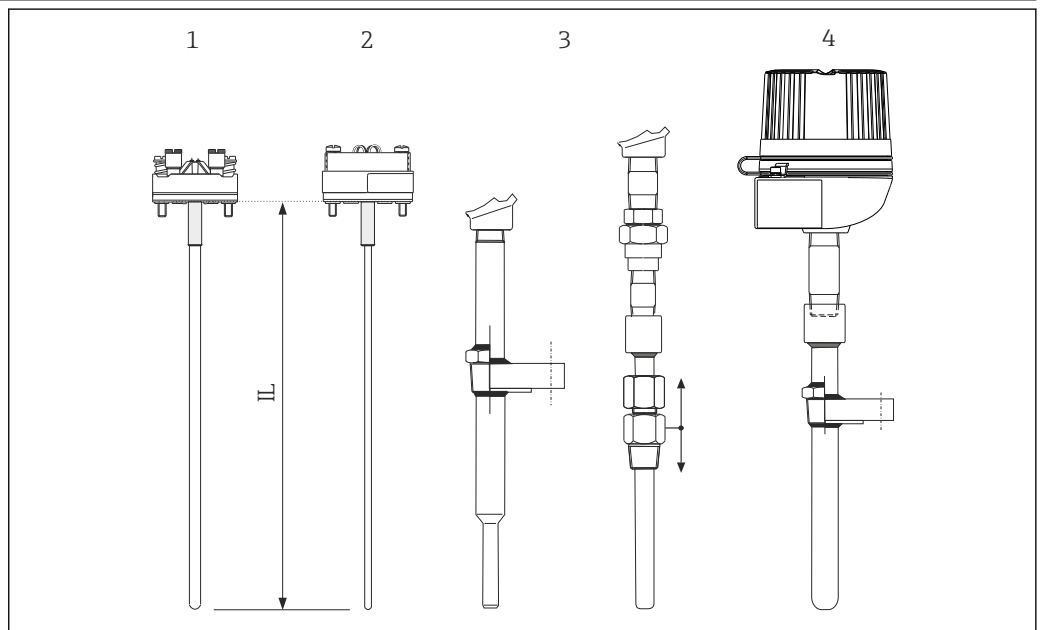

A0017699

- 1 Thermometer design
- 1 Insert with mounted ceramic connection socket (example)
- 2 Insert with mounted head transmitter (example)
- 3 Thermometer with firmly welded and sliding process connections
- 4 Complete thermometer with terminal head and firmly welded thread or flange
- IL Total length of insert

Thermometers from the Omnigrad S TR63 and TC63 series have a modular design. The terminal head is used as a connection module for the mechanical and electrical connection of the insert. The position of the actual thermometer sensor in the insert ensures that it is mechanically protected. The insert can be exchanged and calibrated without interrupting the process. The insert has flying leads, a ceramic connection socket or mounted temperature transmitter.

- Measurement range**
- RTD: -200 to 600 °C (-328 to 1 112 °F)
 - TC: -40 to 1 100 °C (-40 to 2 012 °F)

Performance characteristics

Operating conditions

Ambient temperature

Terminal head	Temperature in °C (°F)
Without mounted head transmitter	Depends on the terminal head used and the cable gland or fieldbus connector, see 'Terminal heads' section (→ 10)
With mounted head transmitter	-40 to 85 °C (-40 to 185 °F)
With mounted head transmitter and display	-20 to 70 °C (-4 to 158 °F)

Process pressure

Process connection	According to standard	Max. process pressure
Thread	ANSI B1.20.1 JIS B 0203	75 bar (1088 psi)
Compression fitting	-	40 bar with metal clamping ring
Flange	ASME B16.5 JIS B 2220	Depending on flange pressure stage 150, 300 or 600 psi

Permitted flow velocity depending on the immersion length

The highest flow velocity tolerated by the thermometer diminishes with increasing immersion length exposed to the stream of the fluid. In addition it is dependent on the diameter of the thermometer tip, on the kind of measuring medium, on the process temperature and on the process pressure. The following figures exemplify the maximum permitted flow velocities in water and superheated steam at a process pressure of 5 MPa (50 bar).

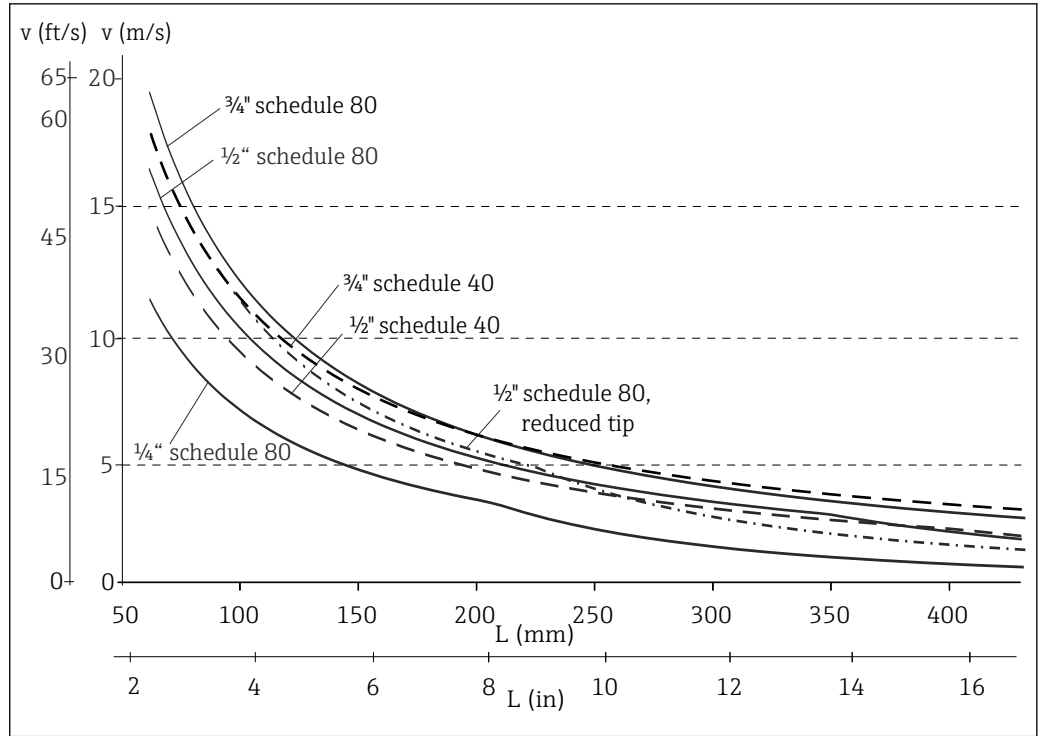

A0017374

2 Permitted flow velocity with different thermometer diameters in the process medium water at $T = 50\text{ }^{\circ}\text{C}$ ($122\text{ }^{\circ}\text{F}$)

L Unsupported immersion length of the thermowell, material 1.4401 (316)
 v Flow velocity

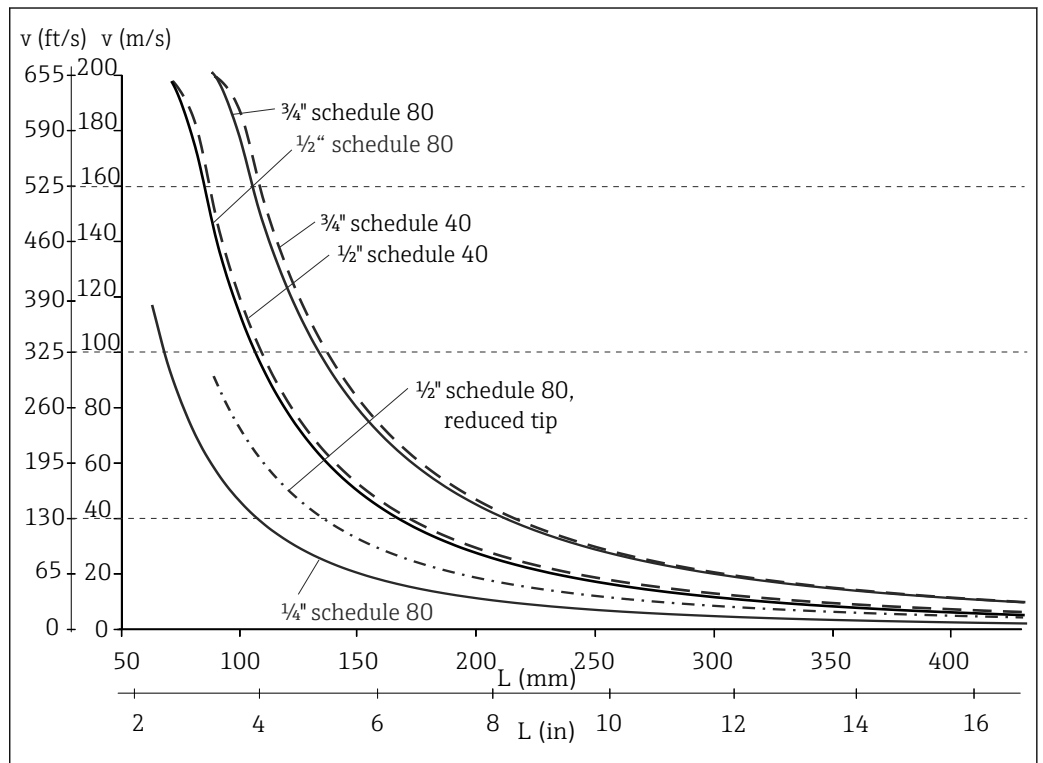

A0017438

3 Permitted flow velocity with different thermometer diameters in the process medium superheated steam at $T = 400\text{ }^{\circ}\text{C}$ ($752\text{ }^{\circ}\text{F}$)

L Unsupported immersion length of the thermowell, material 1.4401 (316)
 v Flow velocity

Shock and vibration resistance

- RTD: 3G / 10 to 500 Hz according to IEC 60751
- TC: 4G / 2 to 150 Hz according to IEC 60068-2-6

Accuracy

RTD resistance thermometer as per IEC 60751

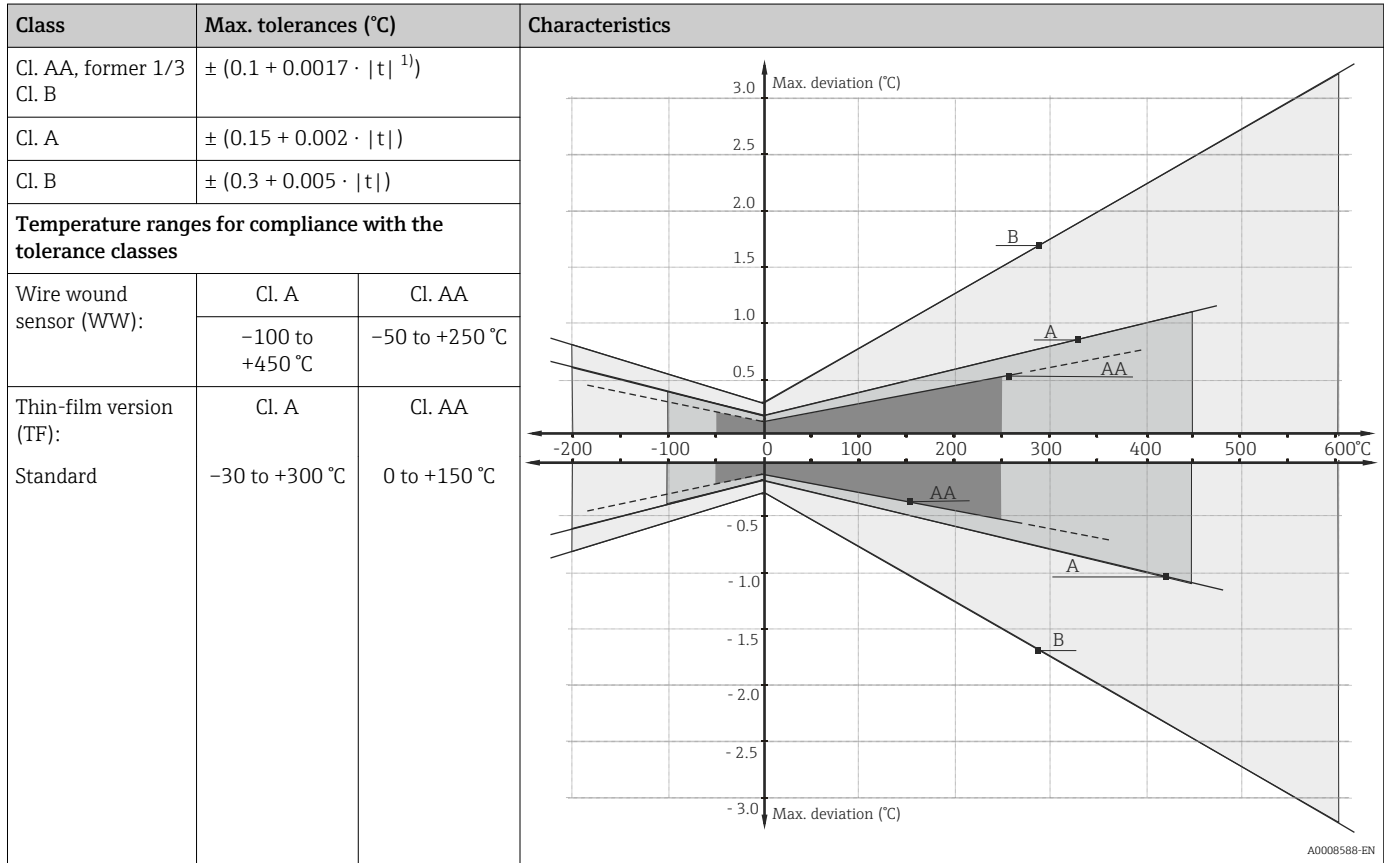

1) |t| = absolute value °C

i In order to obtain the maximum tolerances in °F, the results in °C must be multiplied by a factor of 1.8.

Permissible deviation limits of thermoelectric voltages from the standard characteristic for thermocouples as per IEC 60584 or ASTM E230/ANSI MC96.1:

Standard	Type	Standard tolerance		Special tolerance	
		Class	Deviation	Class	Deviation
IEC 60584	J (Fe-CuNi)	2	$\pm 2.5 \text{ °C } (-40 \text{ to } 333 \text{ °C})$	1	$\pm 1.5 \text{ °C } (-40 \text{ to } 375 \text{ °C})$
			$\pm 0.0075 t ^{1.1} (333 \text{ to } 750 \text{ °C})$		$\pm 0.004 t ^{1.1} (375 \text{ to } 750 \text{ °C})$
		2	$\pm 2.5 \text{ °C } (-40 \text{ to } 333 \text{ °C})$	1	$\pm 1.5 \text{ °C } (-40 \text{ to } 375 \text{ °C})$
K (NiCr-NiAl)	2	2	$\pm 2.5 \text{ °C } (-40 \text{ to } 333 \text{ °C})$	1	$\pm 1.5 \text{ °C } (-40 \text{ to } 375 \text{ °C})$
			$\pm 0.0075 t ^{1.1} (333 \text{ to } 1200 \text{ °C})$		$\pm 0.004 t ^{1.1} (375 \text{ to } 1000 \text{ °C})$

1) |t| = absolute value °C

Standard	Type	Standard tolerance	Special tolerance
ASTM E230/ANSI MC96.1		Deviation, the larger respective value applies	
	J (Fe-CuNi)	$\pm 2.2 \text{ K or } \pm 0.0075 t ^{1)}$ (0 to 760 °C)	$\pm 1.1 \text{ K or } \pm 0.004 t ^{1)}$ (0 to 760 °C)
	K (NiCr-NiAl)	$\pm 2.2 \text{ K or } \pm 0.02 t ^{1)}$ (-200 to 0 °C) $\pm 2.2 \text{ K or } \pm 0.0075 t ^{1)}$ (0 to 1260 °C)	$\pm 1.1 \text{ K or } \pm 0.004 t ^{1)}$ (0 to 1260 °C)

1) |t| = absolute value °C

Response time

The specifications correspond to typical values. The actual response time is dependent on the combination of insert and thermowell. The slightest differences in geometry may result in significant changes.

Calculated at an ambient temperature of approx. 23 °C by immersing in running water (0.4 m/s flow rate, 10 K excess temperature):

Thermometer type	ØQ1 thermowell tip	Response time $t_{(x)}$	RTD WW	RTD TF	TC
Measuring probe Pt100 (TF/WW)	14 mm (0.55 in) ¹⁾	t_{90}	125	90	95
	¼" schedule 80	t_{90}	165	100	115
	½" schedule 80	t_{90}	365	250	335
	½" schedule 40	t_{90}	570	395	450
	¾" schedule 80	t_{90}	795	465	610
	¾" schedule 40	t_{90}	940	540	640

1) reduced tip

 Response time for insert without transmitter.

Insulation resistance

Insulation resistance $\geq 100 \text{ M}\Omega$ at ambient temperature.

Insulation resistance between the terminals and the mineral insulated cable is measured with a voltage of 100 V DC.

Self heating

RTD elements are passive resistances that are measured using an external current. This measurement current causes a self-heating effect in the RTD element itself which in turn creates an additional measurement error. In addition to the measurement current, the size of the measurement error is also affected by the temperature conductivity and flow velocity of the process. This self-heating error is negligible when an Endress+Hauser iTEMP® temperature transmitter (very small measurement current) is connected.

Calibration

Endress+Hauser provides comparison temperature calibration from -80 to +1400 °C (-110 to +2552 °F) based on the International Temperature Scale (ITS90). Calibrations are traceable to national and international standards. The calibration certificate is referenced to the serial number of the thermometer. Only the insert is calibrated.

Insert: Ø6 mm (0.24 in) and 3 mm (0.12 in)	Minimum insertion length of insert in mm (in)	
	without head transmitter	with head transmitter
-80 to -40 °C (-110 to -40 °F)	200 (7.87)	
-40 to 0 °C (-40 to 32 °F)	160 (6.3)	
0 to 250 °C (32 to 480 °F)	120 (4.72)	150 (5.91)

Insert: Ø6 mm (0.24 in) and 3 mm (0.12 in)	Minimum insertion length of insert in mm (in)	
	without head transmitter	with head transmitter
Temperature range		
250 to 550 °C (480 to 1020 °F)	300 (11.81)	
550 to 1400 °C (1020 to 2552 °F)	450 (17.72)	

Material

Extension neck, thermowell, insert.

The temperatures for continuous operation specified in the following table are only intended as reference values for use of the various materials in air and without any significant compressive load. The maximum operation temperatures are reduced considerably in some cases where abnormal conditions such as high mechanical load occur or in aggressive media.

Material name	Short form	Recommended max. temperature for continuous use in air	Properties
AISI 316/1.4401	X5CrNiMo 17-12-2	650 °C (1202 °F) ¹⁾	<ul style="list-style-type: none"> ■ Austenitic, stainless steel ■ High corrosion resistance in general ■ Particularly high corrosion resistance in chlorine-based and acidic, non-oxidizing atmospheres through the addition of molybdenum (e.g. phosphoric and sulfuric acids, acetic and tartaric acids with a low concentration)
AISI 316L/ 1.4404 1.4435	X2CrNiMo17-12-2 X2CrNiMo18-14-3	650 °C (1202 °F)	<ul style="list-style-type: none"> ■ Austenitic, stainless steel ■ High corrosion resistance in general ■ Particularly high corrosion resistance in chlorine-based and acidic, non-oxidizing atmospheres through the addition of molybdenum (e.g. phosphoric and sulfuric acids, acetic and tartaric acids with a low concentration) ■ Increased resistance to intergranular corrosion and pitting ■ Compared to 1.4404, 1.4435 has even higher corrosion resistance and a lower delta ferrite content
AISI A105/1.0460	C22.8	450 °C (842 °F)	<ul style="list-style-type: none"> ■ Heat-resistant steel ■ Resistant in nitrogen-containing atmospheres and atmospheres that are low in oxygen; not suitable for acids or other aggressive media ■ Often used in steam generators, water and steam pipes, pressure vessels

Material name	Short form	Recommended max. temperature for continuous use in air	Properties
AISI 446/1.4749	X18CrNi24	1 100 °C (2 012 °F)	<ul style="list-style-type: none"> ■ A ferritic, heat resistant, high-chromium stainless steel ■ very high resistance to reducing sulphurous gases and salts with low content of oxygen ■ very good resistance to constant as well as cyclical thermal stress, to incineration ashcorrosion and to melts of copper, lead and tin ■ Poorly resistant to gases containing nitrogen
Inconel600/ 2.4816	NiCr15Fe	1 100 °C (2 012 °F)	<ul style="list-style-type: none"> ■ A nickel/chromium alloy with very good resistance to aggressive, oxidizing and reducing atmospheres, even at high temperatures ■ Resistance to corrosion caused by chlorine gases and chlorinated media as well as many oxidizing mineral and organic acids, sea water etc. ■ Corrosion from ultrapure water ■ Not to be used in sulfur-containing atmospheres

- 1) Can be used to a limited extent up to 800 °C (1472 °F) for low compressive loads and in non-corrosive media. Please contact your Endress+Hauser sales team for further information.

Components

Family of temperature transmitters

Thermometers fitted with iTEMP® transmitters are an installation-ready complete solution to improve temperature measurement by significantly increasing accuracy and reliability, when compared to direct wired sensors, as well as reducing both wiring and maintenance costs.

PC programmable head transmitters

They offer a high degree of flexibility, thereby supporting universal application with low inventory storage. The iTEMP® transmitters can be configured quickly and easily at a PC. Endress+Hauser offers free configuration software which can be downloaded from the Endress+Hauser Website. More information can be found in the Technical Information.

HART® programmable head transmitters

The transmitter is a 2-wire device with one or two measuring inputs and one analog output. The device not only transfers converted signals from resistance thermometers and thermocouples, it also transfers resistance and voltage signals using HART® communication. It can be installed as an intrinsically safe apparatus in Zone 1 hazardous areas and is used for instrumentation in the terminal head (flat face) as per DIN EN 50446. Swift and easy operation, visualization and maintenance by PC using operating software, Simatic PDM or AMS. For more information, see the Technical Information.

PROFIBUS® PA head transmitters

Universally programmable head transmitter with PROFIBUS® PA communication. Conversion of various input signals into digital output signals. High accuracy over the complete ambient temperature range. Swift and easy operation, visualization and maintenance using a PC directly from the control panel, e. g. using operating software, Simatic PDM or AMS. For more information, see the Technical Information.

FOUNDATION Fieldbus™ head transmitters

Universally programmable head transmitter with FOUNDATION Fieldbus™ communication. Conversion of various input signals into digital output signals. High accuracy over the complete ambient temperature range. Swift and easy operation, visualization and maintenance using a PC directly from the control panel, e.g. using operating software such as ControlCare from Endress +Hauser or NI Configurator from National Instruments. For more information, see the Technical Information.

Advantages of the iTEMP® transmitters:

- Dual or single sensor input (optionally for certain transmitters)
- Unsurpassed reliability, accuracy and long-term stability in critical processes
- Mathematical functions
- Monitoring of the thermometer drift, sensor backup functionality, sensor diagnostic functions
- Sensor-transmitter matching for dual sensor input transmitters, based on Callendar/Van Dusen coefficients

Terminal heads

All terminal heads have an internal shape and size in accordance with DIN EN 50446, flat face and a thermometer connection of M24x1.5, G1/2" or 1/2" NPT thread. All dimensions in mm (in). The cable glands in the diagrams correspond to M20x1.5 connections. Specifications without head transmitter installed. For ambient temperatures with head transmitter installed, see "Operating conditions" section.

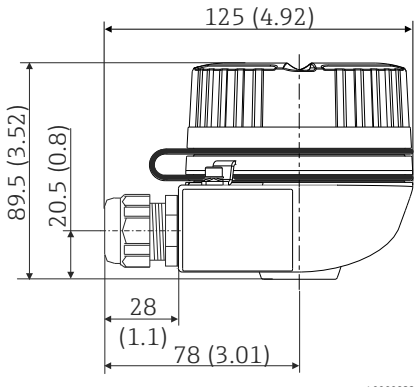
TA30H	Specification
 <p style="text-align: right; font-size: small;">A0009832</p>	<ul style="list-style-type: none"> ▪ Flameproof (XP) version, explosion-protected, captive screw cap, available with one or two cable entries ▪ Protection class: IP 66/68 ▪ Temperature: -50 to +150 °C (-58 to +302 °F) for rubber seal without cable gland (observe max. permitted temperature of cable gland!) ▪ Material: aluminum; polyester powder coated ▪ Thread: ½" NPT, ¾" NPT, M20x1.5, G½" ▪ Extension neck/thermowell connection: ½" NPT ▪ Color of head: blue, RAL 5012 ▪ Color of cap: gray, RAL 7035 ▪ Weight: approx. 640 g (22.6 oz)

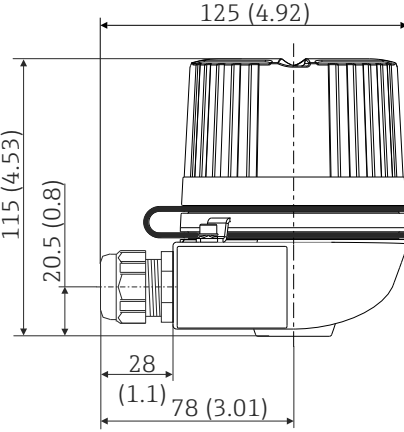
TA30H with display window in cover	Specification
 <p style="text-align: right; font-size: small;">A0009831</p>	<ul style="list-style-type: none"> ▪ Flameproof (XP) version, explosion-protected, captive screw cap, available with one or two cable entries ▪ Protection class: IP 66/68 ▪ Temperature: -50 to +150 °C (-58 to +302 °F) or rubber seal without cable gland (observe max. permitted temperature of cable gland!) ▪ Material: aluminum; polyester powder coated ▪ Thread: ½" NPT, ¾" NPT, M20x1.5, G½" ▪ Extension neck/thermowell connection: ½" NPT ▪ Color of head: blue, RAL 5012 ▪ Color of cap: gray, RAL 7035 ▪ Weight: approx. 860 g (30.33 oz) ▪ Head transmitter optionally available with TID10 display

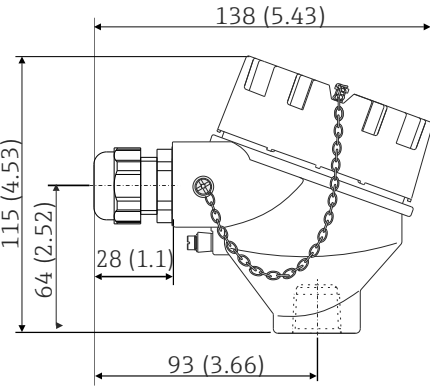
TA21H, DIN B	Specification
 <p style="text-align: right; font-size: small;">A0010194</p>	<ul style="list-style-type: none"> ▪ Head with captive screw cap and safety chain ▪ Protection class: IP 66/68 ▪ Max. temperature: 100 °C (212 °F) for rubber seal without cable gland (observe max. permitted temperature of cable gland!) ▪ Material: aluminum alloy, stainless steel; rubber seal under the cover ▪ Double threaded cable entry: ½" NPT, ¾" NPT, M20 or G½" ▪ Extension neck / thermowell connection: M24x1.5, G½" or ½" NPT ▪ Head color: blue ▪ Cap color: gray ▪ Weight: approx. 600 g (21.16 oz)

Design

All dimensions in mm (in).

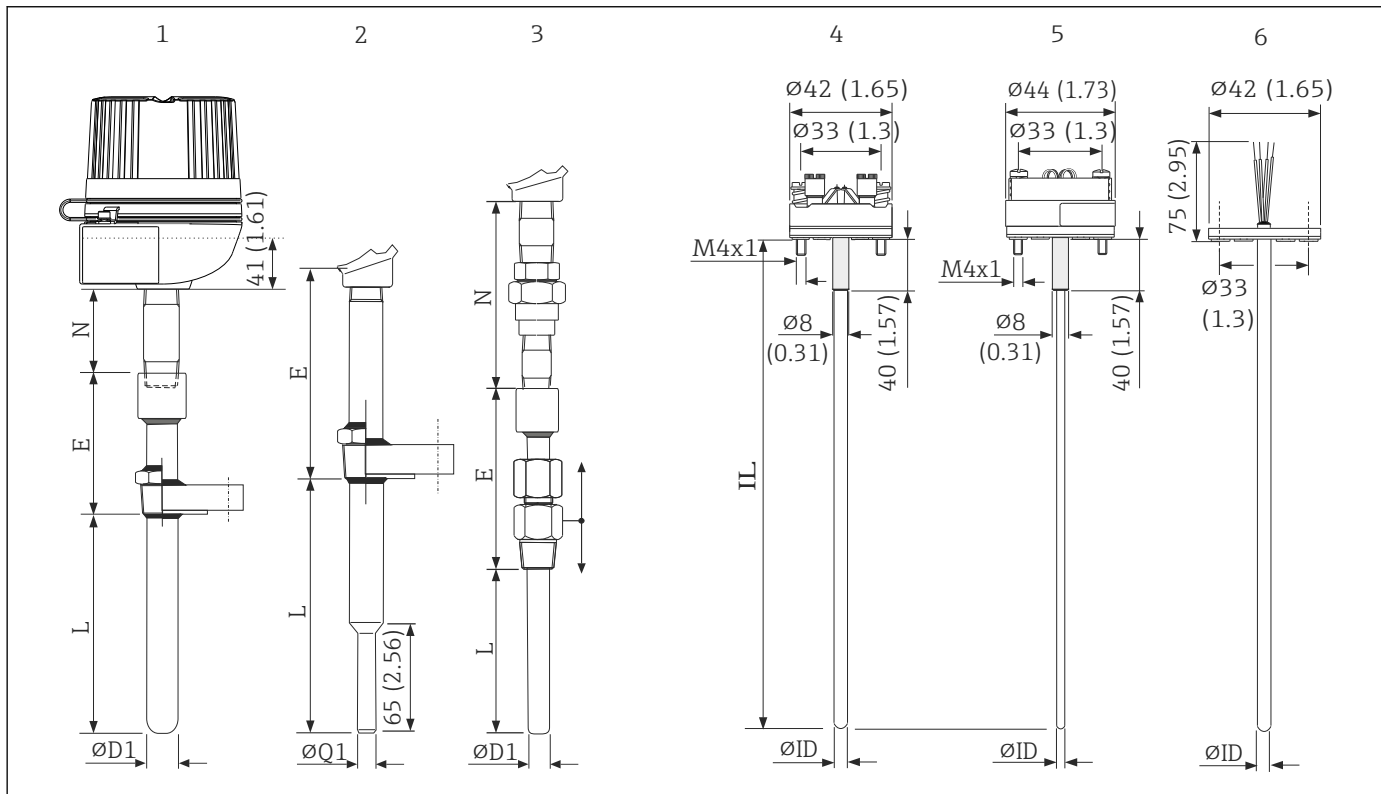

A0017682

4 Dimensions of the Omnigrad S TR63 and TC63

- 1 Complete thermometer with terminal head and firmly welded thread or flange
- 2 Thermometer with firmly welded process connections
- 3 Thermometer with sliding process connection
- 4 Insert with terminal block mounted
- 5 Insert with head transmitter mounted
- 6 Insert with flying leads
- E Thermowell shaft length
- L Immersion length
- N Extension neck length
- IL Total length of insert
- $\phi D1$ Thermowell diameter
- $\phi Q1$ Diameter of reduced tip (14 mm (0.55 in))
- ϕID Insert diameter

Weight

0.5 to 2.5 kg (1 to 5.5 lbs) for standard options.

Process connection

The standard process connections are available as thread, flange or compression fitting. When the process connection is threaded, the connection material is the same as that of the thermowell. Standard material flange: SS 316/1.4401 or ASTM A446 and Inconel600 (RTD).

On request, it is possible to select different materials, finishings and connections.

Type and dimension of the process connections (ASME B16.5, ANSI B1.20.1). All dimensions in mm (in).

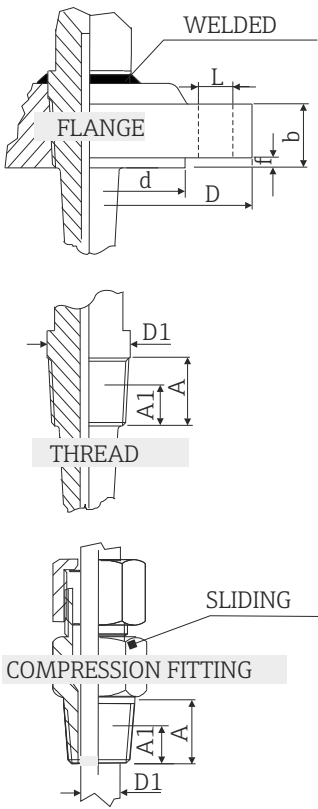
Type		ϕd	ϕD	ϕL	Number of drillings	f	b	$\phi D1$	A	A1		
	Flange	1" ANSI 150 RF SO ¹⁾	50.8 (2)	107.9 (4.25)	15.7 (0.62)	4	1.6 (0.06)	14.2 (0.56)	-	-	-	
		1" ANSI 300 RF SO		124 (4.9)	19.1 (0.75)				17.5 (0.69)	-	-	-
		1" ANSI 600 RF SO						6.4 (0.25)	-	-	-	
		1½" ANSI 150 RF SO	73 (2.9)	127 (5)	15.7 (0.62)	4	1.6 (0.06)	17.5 (0.69)	-	-	-	
		1½" ANSI 300 RF SO		155.4 (6.1)	22.4 (0.85)				20.6 (0.81)	-	-	-
		1½" ANSI 600 RF SO						6.4 (0.25)	-	-	-	
		2" ANSI 300 RF SO	92.1 (3.6)	165.1 (6.5)	19.1 (0.75)	8	1.6 (0.06)	22.4 (0.88)	-	-	-	
		2" ANSI 600 RF SO						6.4 (0.25)	25.4 (1)	-	-	-
		Thread	½" NPT	-	-	-	-	-	-	≥ 21.4 (0.84)	19.9 (0.78)	8.1 (0.32)
			¾" NPT	-	-	-	-	-	-	≥ 26.7 (1.1)	20.2 (0.79)	8.6 (0.34)
1" NPT	-		-	-	-	-	-	≥ 33.4 (1.31)	25.0 (0.98)	10.1 (0.40)		
Compression fitting	1½" NPT	-	-	-	-	-	-	26.70 (1.05)	26 (1.02)	10.6 (0.42)		

1) RF SO: Raised Face Slip On flange (flat flange with sealing face).

Spare parts

- The thermowells (TA540 and TA541) are available as spare parts (→ 19)
- The RTD insert is available as spare part TPR100/TPR300 (→ 19)
- The TC insert is available as spare part TPC100/TPC300 (→ 19)

The inserts are made from mineral insulated cable (MgO) with a sheath in AISI316/1.4401 or Inconel600. The insertion length (IL) of the insert can be chosen within a standard range from 50 to 1000 mm (1.97 to 39.4 in). Inserts with an insertion length of > 1000 mm (39.4 in) can be supplied after a technical verification of the specific application by a Endress+Hauser service

organization. When replacing the insert it is necessary to refer to the following table to obtain the correct insertion length IL (applicable only to thermowells with standard bottom thickness).

Universal or EX certification					
Insert	∅ mm	Connection type	Extension neck lengths in mm (in)	Material	IL in mm (in)
TPx100 / TPx300	3 or 6	N	69 (2.72)	RTD: 316/1.4401	$IL = L + E + 69 (2.72) + 41 (1.61)$
			109 (4.29)	or A105/1.046	$IL = L + E + 109 (4.29) + 41 (1.61)$
TPx100 / TPx300	3 or 6	NU	96 (3.78)	0 TC: Inconel600/ 2.4816 or	$IL = L + E + 96 (3.78) + 41 (1.61)$
TPx100 / TPx300	3 or 6	NUN	148 (5.83)	316L/ 1.4404	$IL = L + E + 148 (5.83) + 41 (1.61)$

Wiring

Wiring diagrams for RTD

Type of sensor connection

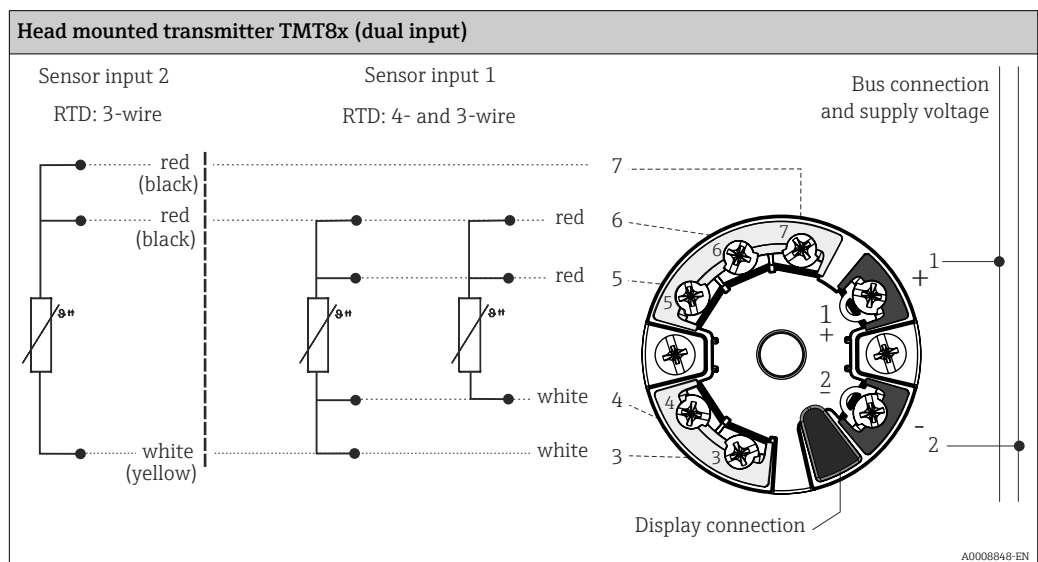
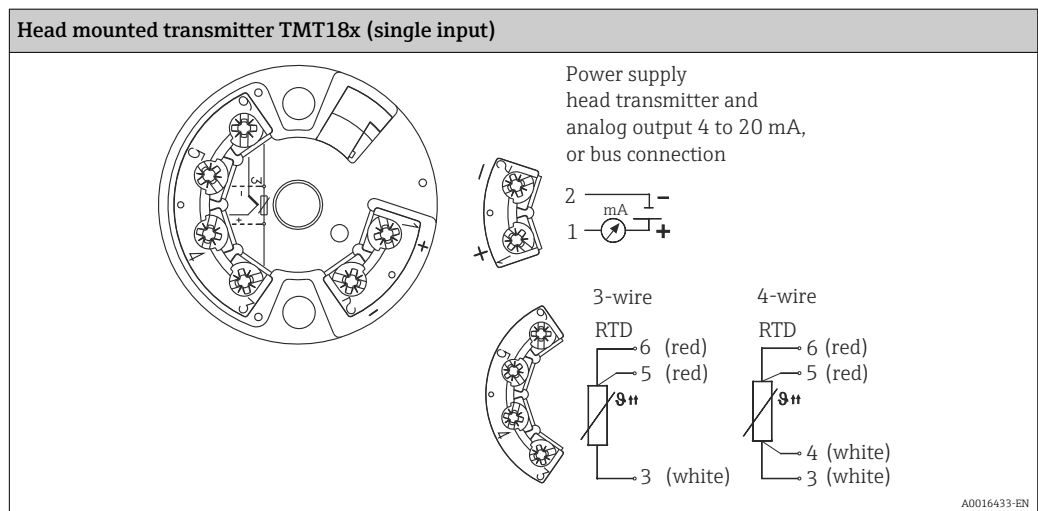

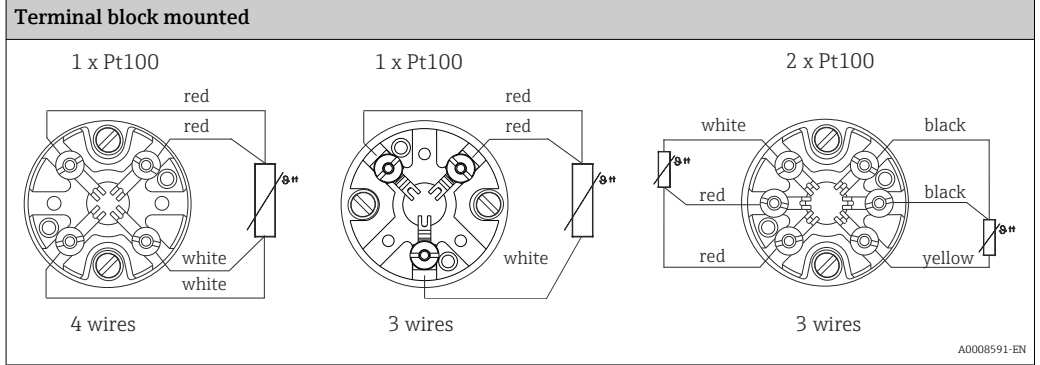

Wiring diagrams for TC

Thermocouple wire colors

As per IEC 60584	As per ASTM E230
<ul style="list-style-type: none"> Type J: black (+), white (-) Type K: green (+), white (-) 	<ul style="list-style-type: none"> Type J: white (+), red (-) Type K: yellow (+), red (-)

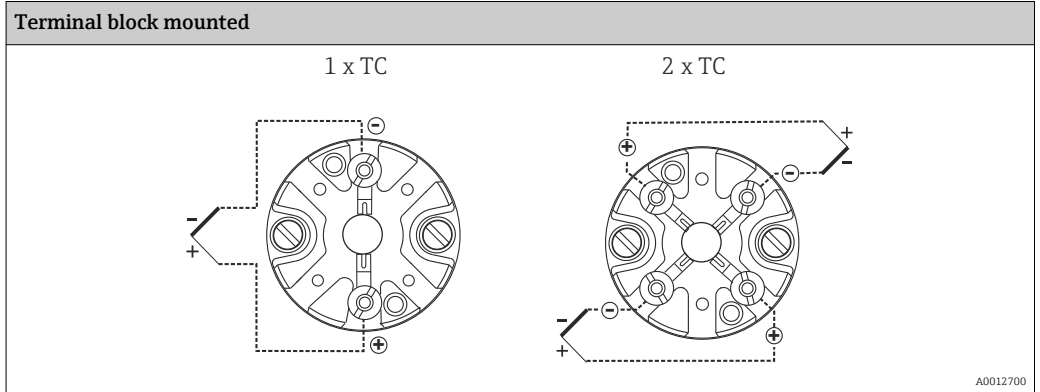
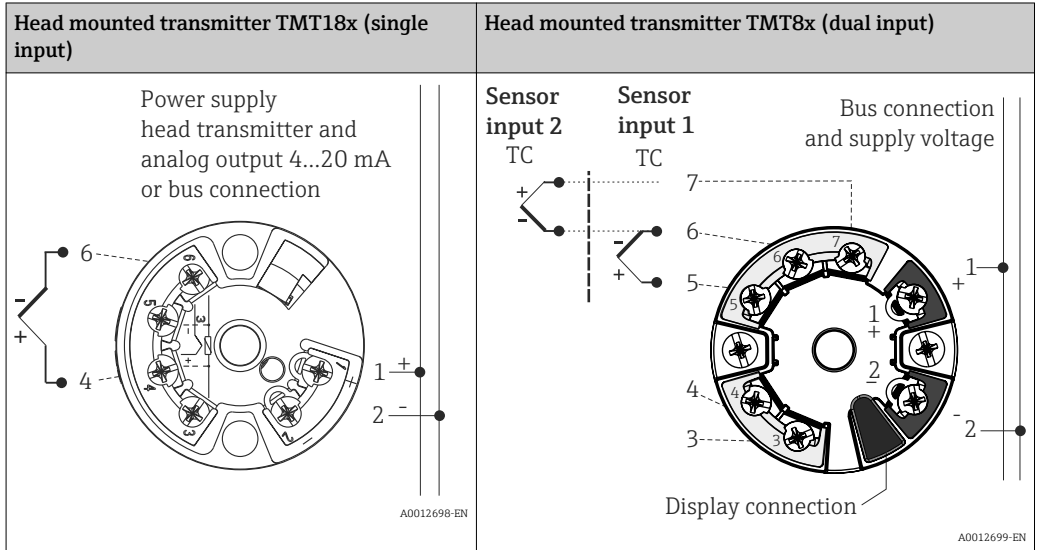

Installation conditions

Orientation

No restrictions.

Installation instructions

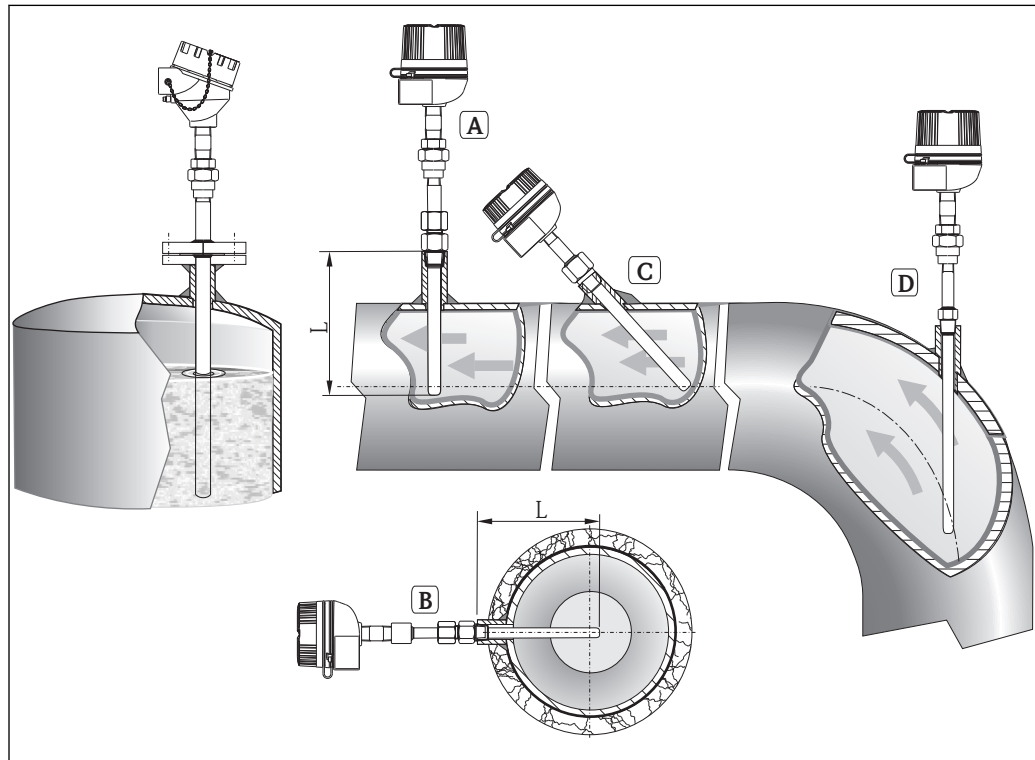

5 Installation examples

A-B In pipes with a small cross section the thermowell tip should reach or extend slightly past the center line of the pipe ($=L$).

C-D Angled installation.

The immersion length of the thermometer influences the accuracy. If the immersion length is too small then errors in the measurement are caused by heat conduction via the process connection and the container wall. If installing into a pipe then the immersion length must be at least half of the pipe diameter (see figure A and B). A further solution could be an angled (tilted) installation (see figure C and D). When determining the immersion length all thermometer parameters and the process to be measured must be taken into account (e.g. flow velocity, process pressure).

As far as corrosion is concerned, the base material for parts in contact with the fluid is able to withstand the most common corrosive agents up to the highest temperatures. For further information on specific applications, contact a Endress+Hauser service organization.

i The counterparts for process connections and gaskets, when required, are not supplied with the sensor and must be purchased separately.

- Installation possibilities: Pipes, tanks or other plant components
- Recommended minimum immersion length = 80 to 100 mm (3.15 to 3.94 in). The immersion length should correspond to at least 8 times of the thermowell diameter. Example: Thermowell diameter 12 mm (0.47 in) x 8 = 96 mm (3.8 in). A standard immersion length of 120 mm (4.72 in) is recommended.
- ATEX certification: Always take note of the installation regulations!

Extension neck

The extension neck is the part between the process connection and the terminal head. The neck is constituted by a tube assembled to hydraulic hardware (nipples or joints) that is suitable to allow the adjustment of the sensor to the thermowell. In addition to the standard versions listed below, it is also possible to order the extension neck by specifying the desired length (see Product Configurator, chapter "Ordering information"). (→  18)

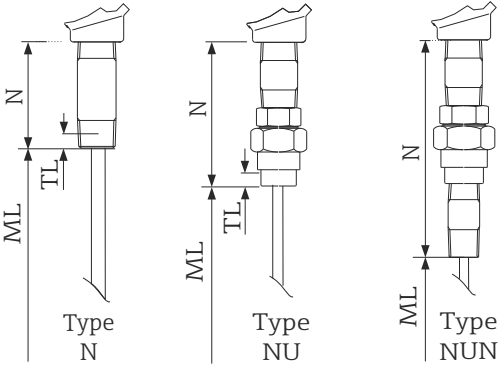
Type	Thermowell connection	Extension neck length in mm (in)
	Type N	½" NPT external thread
	Type NU	½" NPT internal thread
	Type NUN	½" NPT external thread
		69 mm (2.72 in) 109 mm (4.3 in) 96 mm (3.8 in) 148 mm (5.83 in)

As illustrated in the following figure, the extension neck length may influence the temperature in the terminal head. This temperature must remain within the limit values defined in the "Operating conditions" section. (→  4)

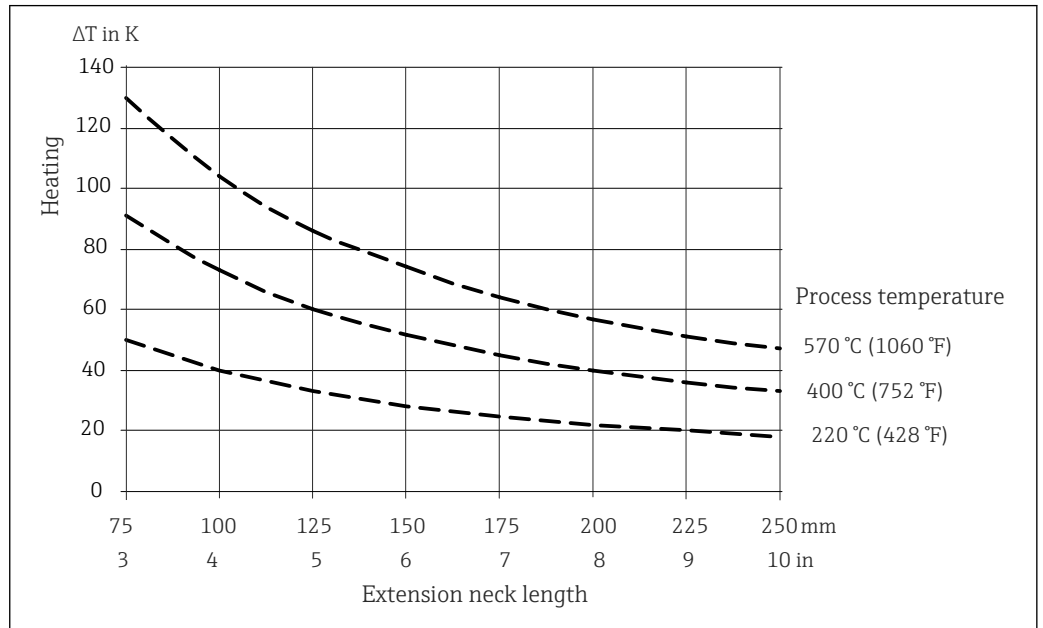

 6 Heating of the terminal head consequent to the process temperature. Temperature in terminal head = ambient temperature 20 °C (68 °F) + ΔT

Certificates and approvals

CE Mark	The device meets the legal requirements of the EC directives if applicable. Endress+Hauser confirms that the device has been successfully tested by applying the CE mark.
Hazardous area approvals	For further details on the available Ex versions (ATEX, CSA, FM etc.), please contact your nearest Endress +Hauser sales organization. All relevant data for hazardous areas can be found in separate Ex documentation.
Other standards and guidelines	<ul style="list-style-type: none"> ▪ EN 60079: ATEX certification for hazardous areas ▪ IEC 60529: Degree of protection of housing (IP code) ▪ IEC 61010-1: Protection Measures for Electrical Equipment for Measurement, Control, Regulation and Laboratory Procedures ▪ IEC 60751: Industrial platinum resistance thermometers ▪ IEC 60584 and ASTM E230/ANSI MC96.1: Thermocouples ▪ EN 50014/18: Electrical equipment for hazardous areas - General regulations/Flameproof enclosure "d" ▪ DIN 43772: Thermowells ▪ DIN EN 50446: Terminal heads ▪ IEC 61326-1: Electromagnetic compatibility (EMC requirements)
PED approval	The thermometer complies with paragraph 3.3 of the Pressure Equipment Directive 97/23/CE and is not marked separately.
Test on thermowell	Thermowell pressure tests are carried out in accordance with the specifications in DIN 43772. With regard to thermowells with tapered or reduced tips that do not comply with this standard, these are tested using the pressure of corresponding straight thermowells. Sensors for use in hazardous areas are also always subjected to a comparative pressure during the tests. Tests according to other specifications can be carried out on request. The liquid penetration test verifies that there are no cracks in the welded seams of the thermowell.
Test report and calibration	The "Factory calibration" is carried out according to an internal procedure in a laboratory of Endress +Hauser accredited by the European Accreditation Organization (EA) according to ISO/IEC 17025. A calibration which is performed according to EA guidelines (SIT/Accredia or DKD/DAKks calibration) may be requested separately. The calibration is performed on the replaceable insert of the thermometer. In the case of thermometers without a replaceable insert, the entire thermometer - from the process connection to the tip of the thermometer - is calibrated.

Ordering information

Detailed ordering information is available from the following sources:

- In the Product Configurator on the Endress+Hauser website: www.endress.com → Select country → Instruments → Select device → Product page function: Configure this product
- From your Endress+Hauser Sales Center: www.endress.com/worldwide



Product Configurator - the tool for individual product configuration

- Up-to-the-minute configuration data
- Depending on the device: Direct input of measuring point-specific information such as measuring range or operating language
- Automatic verification of exclusion criteria
- Automatic creation of the order code and its breakdown in PDF or Excel output format
- Ability to order directly in the Endress+Hauser Online Shop

Documentation

Technical Information:

- Temperature head transmitter:
 - iTEMP[®] TMT180, PC programmable, single-channel, Pt100 (TI00088R/09/en)
 - iTEMP[®] PCP TMT181, PC programmable, single-channel, RTD, TC, Ω, mV (TI00070R/09/en)
 - iTEMP[®] HART[®] TMT182, single-channel, RTD, TC, Ω, mV (TI078R/09/en)
 - iTEMP[®] HART[®] TMT82, two-channel, RTD, TC, Ω, mV (TI01010T/09/en)
 - iTEMP[®] PROFIBUS[®] PA TMT84, two-channel, RTD, TC, Ω, mV (TI00138R/09/en)
 - iTEMP[®] FOUNDATION Fieldbus[™] TMT85, two-channel, RTD, TC, Ω, mV (TI00134R/09/en)
- Application example:
 - RN221N Active barrier, for supplying loop-powered transmitters (TI073R/09/en)
 - RIA16 Field display unit, loop-powered (TI00144R/09/en)
- Thermowells
 - Industrial thermowell Omnigrad TA540, threaded or flanged weld type (TI00166T/09/en)
 - Industrial thermowell Omnigrad TA541, threaded or flanged weld type (TI188T/02/en)

Hazardous area (ATEX) supplementary documentation:

- RTD/TC Thermometer Omnigrad TRxx, TCxx, TxCxxx, ATEX II 1GD or II 1/2GD Ex ia IIC T6...T1 (XA00072R/09/a3)
- RTD/TC Thermometer Omnigrad S TR/TC6x, ATEX II1/2, 2GD or II2G (XA014T/02/a3)
- RTD/TC Thermometer Omnigrad S TR/TC6x, ATEX II 1/2 or 2G; II 1/2 or 2D; II 2G (XA00084R/09/a3)

www.addresses.endress.com
