

# Technical Information

## RTD Insert TPR100

Mineral insulated insert thermoresistance sensing element



### Applications

- For universal use
- RTD measuring range: -200 to +600 °C (-328 to +1112 °F)
- For installation in thermometers

### Head transmitter

All Endress+Hauser transmitters are available with enhanced accuracy and reliability compared to directly wired sensors. Easy customizing by choosing one of the following outputs and communication protocols:

- Analog output 4 to 20 mA
- HART®
- PROFIBUS® PA
- FOUNDATION Fieldbus™

### Your benefits

- High degree of flexibility thanks to customized immersion lengths
- Different kinds of Pt100 and classes of tolerance (IEC 60751):
  - wire wound type, class A or 1/3 DIN B, single or double
  - thin film type, class A or 1/3 DIN B
- 4 wires connection for single Pt100, 3 wires connection for double Pt100
- Factory calibration certificate
- Approvals for use in hazardous areas

## Table of contents

<b>Function and system design</b> . . . . .	<b>3</b>
Measuring principle . . . . .	3
Equipment architecture . . . . .	3
<b>Input</b> . . . . .	<b>3</b>
Measuring range . . . . .	3
<b>Output</b> . . . . .	<b>3</b>
Output signal . . . . .	3
Family of temperature transmitters . . . . .	3
<b>Performance characteristics</b> . . . . .	<b>5</b>
Maximum measured error . . . . .	5
Calibration . . . . .	6
Maximum process pressure . . . . .	6
Process temperature . . . . .	6
Maximum flow velocity . . . . .	7
Self heating . . . . .	7
Response time . . . . .	7
Insulation resistance . . . . .	7
<b>Installation</b> . . . . .	<b>7</b>
Installation instructions . . . . .	7
<b>Environment</b> . . . . .	<b>9</b>
Vibration and shock resistance . . . . .	9
<b>Mechanical construction</b> . . . . .	<b>9</b>
Design, dimensions . . . . .	9
Weight . . . . .	10
Material . . . . .	10
<b>Certificates and approvals</b> . . . . .	<b>10</b>
CE mark . . . . .	10
Ex approvals . . . . .	10
EAC mark . . . . .	10
Other standards and guidelines . . . . .	10
Inspection certificates . . . . .	10
MID . . . . .	10
<b>Ordering information</b> . . . . .	<b>10</b>
<b>Supplementary documentation</b> . . . . .	<b>11</b>

## Function and system design

### Measuring principle

In RTD (Resistance Temperature Detector) inserts the sensing element consists of an electrical resistance with value of 100 Ω at 0 °C (called Pt100, in compliance with standard IEC 60751), which increases at higher temperatures according to a coefficient characteristic of the resistor material (Platinum). In industrial thermometers compliant with IEC 60751 standard, the value of that coefficient is  $\alpha=3.85 \cdot 10^{-3} \text{ } ^\circ\text{C}^{-1}$ , calculated between 0 and 100 °C.

### Equipment architecture

The TPR100 is made up of a MgO cable sheathed in SS 316L/1.4404 with 6 or 3 mm diameter; the sensing element (Pt100) is positioned close to the tip of the probe. A tapered tip is also available and it's obtained from a 6 mm sheath reduced in the last 50 mm to a 3 mm outer diameter. At the opposite extremity the insert has a washer, which is crimped on the stem. The function of the washer is to stop the insert at the right insertion length, when assembled with a connection head.

The version having the flying leads as terminals, is indicated if the insert has to be connected directly to a head transmitter, otherwise there is the alternative with the terminal block, which is permanently fixed to the washer.

When a TPR100 is mounted into a sensor with thermowell, it is fixed by means of two spring-loaded screws, which allow the tip of the insert to go properly in contact with the bottom of the thermowell, ensuring in this way a better thermal contact. The springs are useful also to compensate the thermal expansion.

The electrical structure of the instrument always complies with IEC 60751 standard rules.

The sensing element is supplied in the two versions thin film (TF) or wire wound (WW), the last having an extended range of measurement and accuracy.

## Input

### Measuring range

Sensor type	Measuring range	Connection type	Temperature-sensitive length
Pt100 thin-film sensor (TF)	-50 to 400 °C (-58 to 752 °F)	3- or 4-wire	10 mm (0.39 in)
Pt100 wire-wound sensor (WW)	-200 to 600 °C (-328 to 1112 °F)	3- or 4-wire	10 mm (0.39 in)

## Output

### Output signal

Generally, the measured value can be transmitted in one of two ways:

- Directly-wired sensors - sensor measured values forwarded without a transmitter.
- Via all of the usual protocols by selecting an appropriate Endress+Hauser iTEMP temperature transmitter. All the transmitters listed below are mounted directly in the washer of the insert and wired with the sensory mechanism. This part of the insert is later placed in the terminal head of the thermometer..

### Family of temperature transmitters

Thermometers fitted with iTEMP transmitters are an installation-ready complete solution to improve temperature measurement by significantly increasing accuracy and reliability, when compared to direct wired sensors, as well as reducing both wiring and maintenance costs.

#### 4 to 20 mA head transmitters

They offer a high degree of flexibility, thereby supporting universal application with low inventory storage. The iTEMP transmitters can be configured quickly and easily at a PC. Endress+Hauser offers free configuration software which can be downloaded from the Endress+Hauser Website. More information can be found in the Technical Information.

#### HART® head transmitters

The transmitter is a 2-wire device with one or two measuring inputs and one analog output. The device not only transfers converted signals from resistance thermometers and thermocouples, it also transfers resistance and voltage signals using HART® communication. Swift and easy operation,

visualization and maintenance using universal device configuration tools like FieldCare, DeviceCare or FieldCommunicator 375/475. Integrated Bluetooth® interface for the wireless display of measured values and configuration via E+H SmartBlue (app), optional. For more information, see the Technical Information.

**PROFIBUS® PA head transmitters**

Universally programmable head transmitter with PROFIBUS® PA communication. Conversion of various input signals into digital output signals. High accuracy over the complete ambient temperature range. The configuration of PROFIBUS PA functions and of device-specific parameters is performed via fieldbus communication. For more information, see the Technical Information.

**FOUNDATION Fieldbus™ head transmitters**

Universally programmable head transmitter with FOUNDATION Fieldbus™ communication. Conversion of various input signals into digital output signals. High accuracy over the complete ambient temperature range. All transmitters are released for use in all important process control systems. The integration tests are performed in Endress+Hauser's "System World". For more information, see the Technical Information.

Advantages of the iTEMP transmitters:

- Dual or single sensor input (optionally for certain transmitters)
- Pluggable display (optionally for certain transmitters)
- Unsurpassed reliability, accuracy and long-term stability in critical processes
- Mathematical functions
- Monitoring of the thermometer drift, sensor backup functionality, sensor diagnostic functions
- Sensor-transmitter matching for dual sensor input transmitters, based on Callendar/Van Dusen coefficients

## Performance characteristics

### Maximum measured error

RTD resistance thermometers as per IEC 60751:

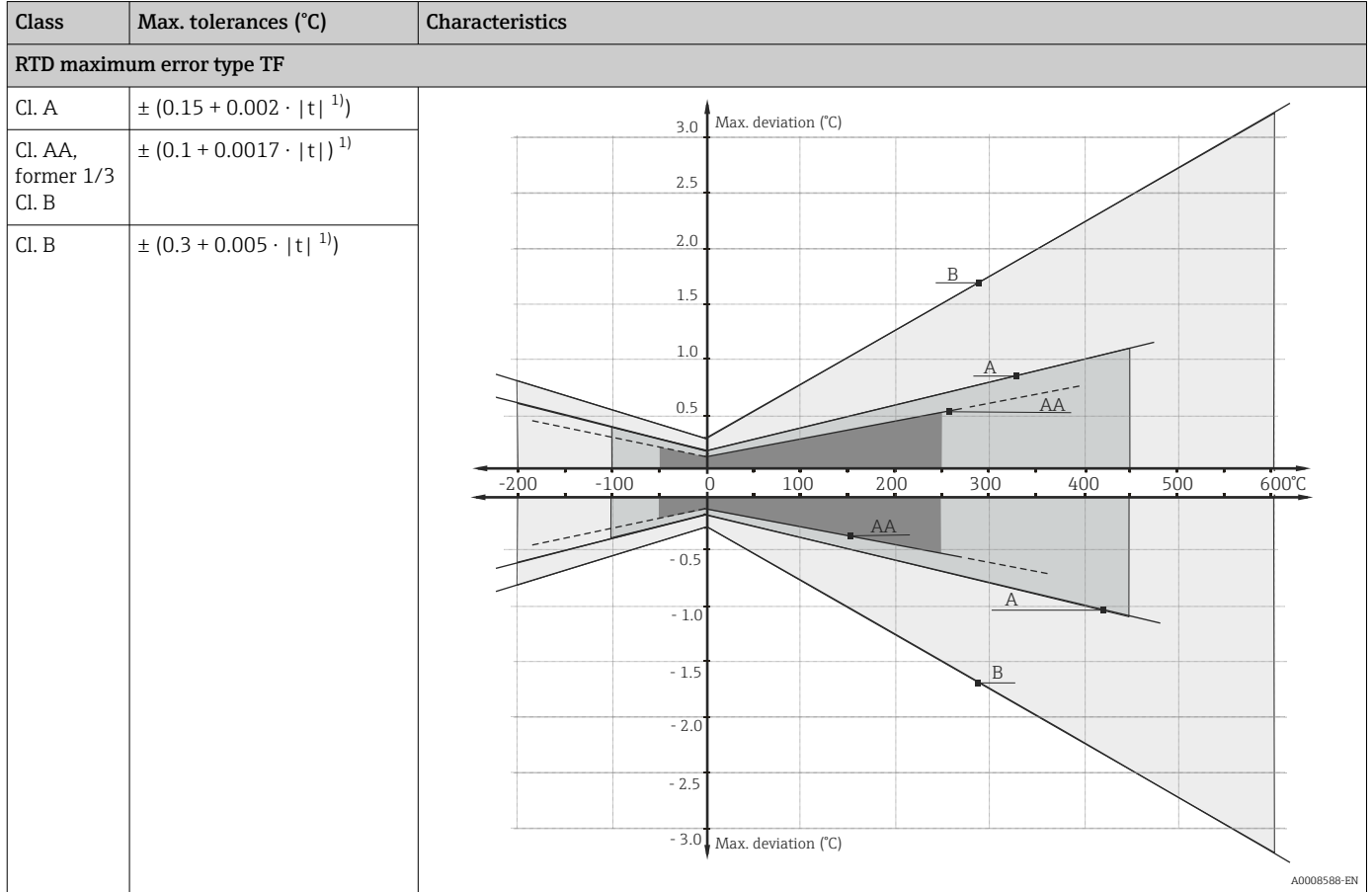

1) |t| = absolute temperature value in °C

In order to obtain the maximum tolerances in °F, the results in °C must be multiplied by a factor of 1.8.

### Temperature ranges

Sensor type	Operating temperature range	Class A	Class AA
Thin-film sensor (TF)	-50 to +400 °C (-58 to +752 °F)	-50 to +250 °C (-58 to +482 °F)	0 to +100 °C (+32 to +212 °F)
Wire wound sensor (WW)	-200 to +600 °C (-328 to +1112 °F)	-200 to +600 °C (-328 to +1112 °F)	-50 to +250 °C (-58 to +482 °F)

## Calibration

### Calibration of thermometers

Calibration involves comparing the measured values of a device under test (DUT) with those of a more precise calibration standard using a defined and reproducible measurement method. The aim is to determine the deviation of the DUT's measured values from the true value of the measured variable. Two different methods are used for thermometers:

- Calibration at fixed-point temperatures, e.g. at the freezing point of water at 0 °C,
- Calibration compared against a precise reference thermometer.

The thermometer to be calibrated must display the fixed point temperature or the temperature of the reference thermometer as accurately as possible. Temperature-controlled calibration baths with very homogeneous thermal values, or special calibration furnaces are typically used for thermometer calibrations. The measuring uncertainty may increase due to heat conduction errors and short immersion lengths. The existing measuring uncertainty is recorded on the individual certificate of calibration. For accredited calibrations in accordance with ISO17025, a measuring uncertainty that is twice as high as the accredited measuring uncertainty is not permitted. If this limit is exceeded, only a factory calibration is possible.

### Sensor transmitter matching

The resistance/temperature curve of platinum resistance thermometers is standardized but in practice it is rarely possible to keep to the values precisely over the entire operating temperature range. For this reason, platinum resistance sensors are divided into tolerance classes, such as Class A, AA or B as per IEC 60751. These tolerance classes describe the maximum permissible deviation of the specific sensor characteristic curve from the standard curve, i.e. the maximum temperature-dependent characteristic error that is permitted. The conversion of measured sensor resistance values to temperatures in temperature transmitters or other meter electronics is often susceptible to considerable errors as the conversion is generally based on the standard characteristic curve.

When using E+H temperature transmitters, this conversion error can be reduced significantly by sensor-transmitter matching:

- Calibration at three temperatures at least and determination of the actual temperature sensor characteristic curve,
- Adjustment of the sensor-specific polynomial function using Calendar-van Dusen (CvD) coefficients,
- Configuration of the temperature transmitter with the sensor-specific CvD coefficients for resistance/temperature conversion, and
- another calibration of the reconfigured temperature transmitter with connected resistance thermometer.

For the device, Endress+Hauser offers standard calibrations at a reference temperature of -80 to +600 °C (-112 to +1 112 °F) based on the ITS90 (International Temperature Scale). Calibrations in other temperature ranges are available from your Endress+Hauser sales center on request. Calibrations are traceable to national and international standards. The calibration certificate is referenced to the serial number of the device. Only the insert is calibrated.

### Minimum insertion length (IL) for inserts required to perform a correct calibration

 Due to the limitations of furnace geometries, the minimum insertion lengths must be observed at high temperatures to enable a calibration to be performed with an acceptable degree of measuring uncertainty. The same applies when using a head transmitter. Due to heat conduction, minimum lengths must be observed in order to guarantee the functionality of the transmitter -40 to +85 °C (-40 to +185 °F)

Calibration temperature	Minimum insertion length IL in mm without head transmitter
-196 °C (-320.8 °F)	120 mm (4.72 in) <sup>1)</sup>
-80 to 250 °C (-112 to 482 °F)	No minimum insertion length required <sup>2)</sup>
251 to 550 °C (483.8 to 1022 °F)	300 mm (11.81 in)
551 to 600 °C (1023.8 to 1112 °F)	400 mm (15.75 in)

1) Min. 150 mm (5.91 in) required with TMT

2) At a temperature of +80 to +250 °C (+176 to +482 °F) and with TMT, min. 50 mm (1.97 in) is required

**Maximum process pressure** 2 MPa (20 bar) at 20 °C

**Process temperature** -200 to +600 °C (-328 to +1 112 °F)

**Maximum flow velocity** When in direct contact with process fluid, the highest flow velocity tolerated by the insert diameter diminishes with increasing lengths exposed to the stream of fluid.

**Self heating** Negligible when an Endress+Hauser iTEMP temperature transmitter is used.

**Response time** *Test in water at 0.4 m/s (according to IEC 60751; 23 to 33 °C step changes):*

Insert				
Sensor type	Diameter ID	Number of sensors	Response time	
Wire wound sensor (WW)	3 mm (1/8 in)	single sensor	t <sub>50</sub> t <sub>90</sub>	<2 s <5 s
	6 mm (1/4 in)	single sensor	t <sub>50</sub> t <sub>90</sub>	<4 s <10.5 s
	3 mm (1/8 in)	double sensor	t <sub>50</sub> t <sub>90</sub>	<2 s <5 s
	6 mm (1/4 in)	double sensor	t <sub>50</sub> t <sub>90</sub>	<4.5 s <12 s
Thin-film sensor (TF)	3 mm (1/8 in)	single sensor	t <sub>50</sub> t <sub>90</sub>	<2.5 s <5.5 s
	6 mm (1/4 in)	single sensor	t <sub>50</sub> t <sub>90</sub>	<5 s <13 s

**Insulation resistance** Insulation resistance as per IEC 60751 with a minimum test voltage of 100 V DC:  
> 100 MΩ at 25 °C

## Installation

**Installation instructions** TPR100 is normally mounted into thermometer assemblies where a thermoresistance is required. The installation inside an assembly is very easy: it's enough to insert the TPR100 into a housing and to screw down in the appropriate holes the two spring-loaded screws, in order to fix the washer to the internal base of the housing.

The insertion length (IL) of an insert has a considerable role, since the tip of the probe must be in contact with the bottom of the host thermowell. In this way the thermal transfer from the wall of the thermowell to the sensing element is assured, and the response time will be surely reduced. Moreover it should be a good rule to leave less empty space as possible between insert and thermowell, in order to enhance the heat transmission; therefore the right insert diameter must be chosen with regard to the well bore diameter.

TPR100 can be also used directly for the temperature measurement, avoiding the employment of a protection well; for this solution a process connection (usually an adjustable one like a compression fitting) will fix the insert to the pipe or vessel, and define the right immersion length.

Thanks to the construction with mineral insulated cable, the insert can be easily bended up to a radius of 3 times the insert diameter.

In case of vibrations, the thin film (TF) sensing element may offer some advantages, but the behaviour depends on intensity, direction and dominant frequency in the vibrational motion.

On the contrary the wire wound (WW) Pt100, besides a wider range of measurement and accuracy, assures a better long term stability.

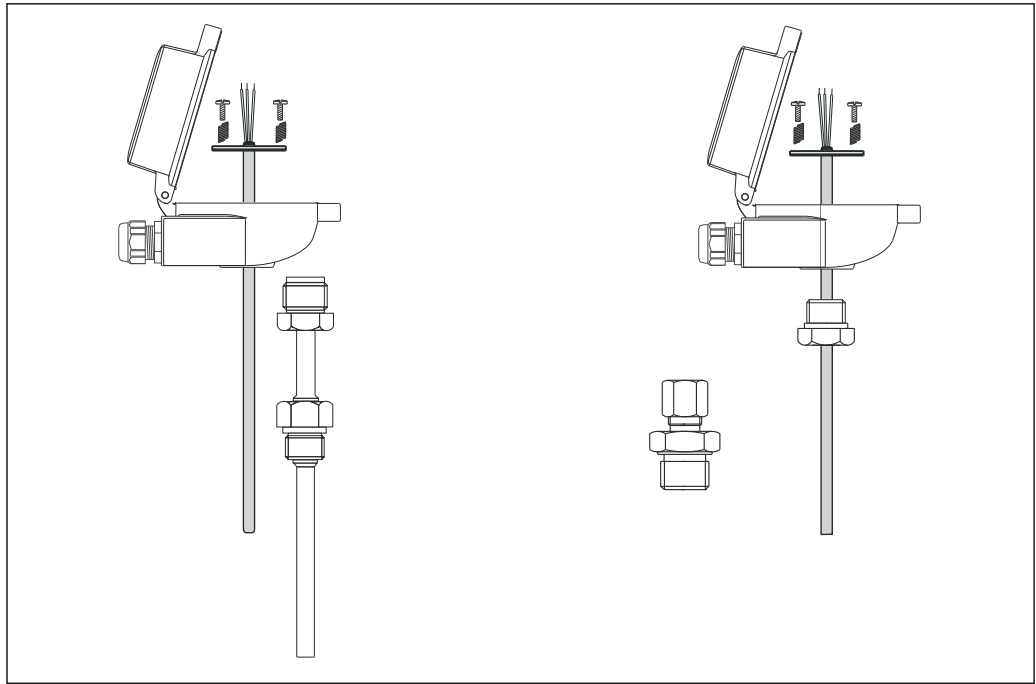

A0019385

1 General installation options: in an assembly with thermowell (left), direct measurement (right)

**Possible bending radius**

Shape of tip for RTD resistance thermometers:

Sensor type	Shape of tip	Insert diameter ID	Non-flexible length (tip) NL
Pt100 thin-film sensor (TF)	Even	Ø3 mm (1/8 in) Ø6 mm (1/4 in)	30 mm (1.18 in)
Pt100 wire-wound sensor (WW)	Even	Ø3 mm (1/8 in) Ø6 mm (1/4 in)	30 mm (1.18 in)

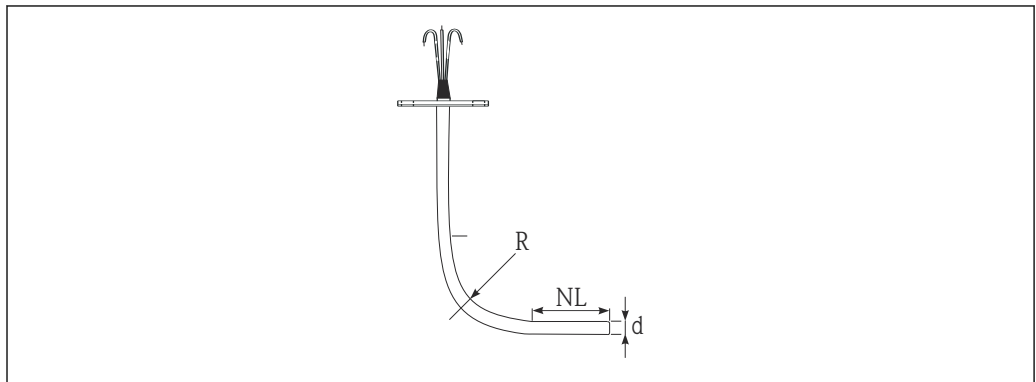

A0019386



## Environment

### Vibration and shock resistance

The inserts exceed the requirements of IEC 60751, which specify shock and vibration resistance of 3 g in the range from 10 to 500 Hz.

## Mechanical construction

### Design, dimensions

All dimensions in mm (in).

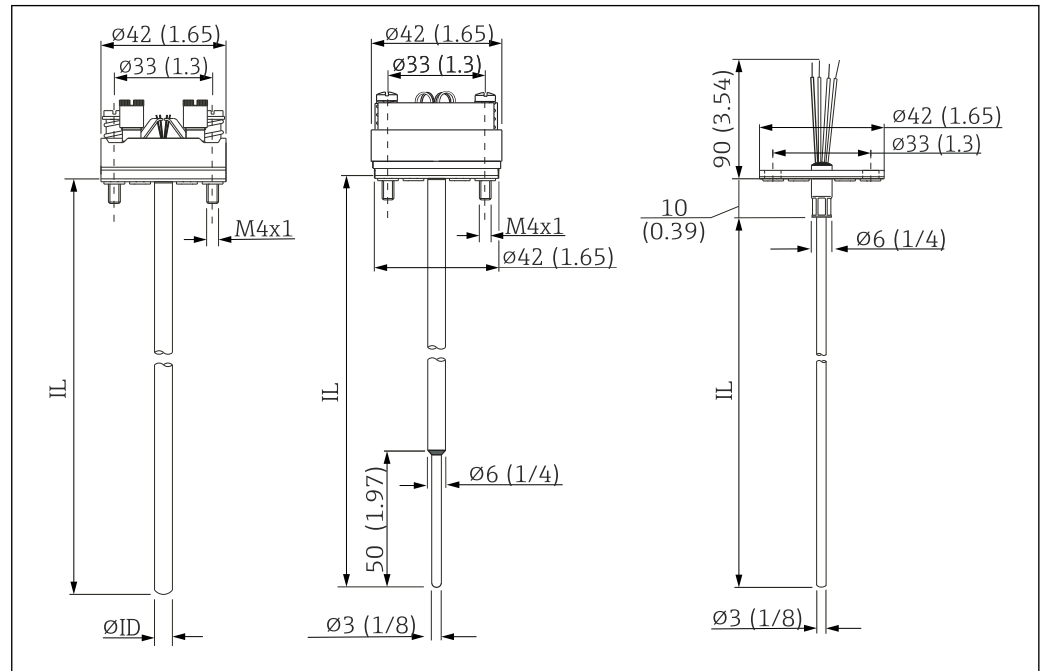

2 Design and dimensions of the TPR100

$\varnothing ID$  Insert diameter  $\varnothing 3$  mm ( $1/8$  in) or  $\varnothing 6$  mm ( $1/4$  in)

IL Insert length

TPR100 is a measuring probe itself, constituted by a mineral insulated (MgO) cable, usually positioned inside a thermowell. The outer diameter of the mineral insulated cable can be 6 mm ( $1/4$  in) or 3 mm ( $1/8$  in) in the straight version, or 6 mm ( $1/4$  in) tapered to 3 mm ( $1/8$  in) in the last 50 mm (1.97 in). The tapered version is used for a fast response time in reduced tip thermowells; for this version an immersion length of at least 80 mm (3.15 in) is required. The sensing element is placed in the ending part of the insert in order to go strict in contact with the bottom of the hosting thermowell; at the opposite side of the insert a washer is crimped.

Its function is to stop the insert at the right position when it has to be assembled into a terminal head and to be the support base of a transmitter or the ceramic block. The flying leads allow the connection to the head transmitter, while the ceramic terminal block (fixed onto the washer) is suggested where no head transmitter is employed.

For its replacement, the insert length (IL) must be chosen depending on the kind of sensor (with or without extension neck) and the related immersion length (U) of the thermowell. Should a spare part be required, please refer to the technical information of the thermometer assembly.

The immersion length is available in some standard values or it can be supplied in a "customized" version within a range. Although the wiring diagram of single Pt100 is always supplied with 4 wires configuration, the connection of a transmitter can be executed with 3 wires as well, by avoiding to connect whichever of the terminals.

The double Pt100 version with 2 wires connection is available only for TPR100 with certification for the application in hazardous areas. The use of standard lengths allows the customer to obtain short

delivery times and so to reduce the necessity of big stocks. Standard lengths moreover, facilitate the exchangeability of inserts in standard length thermowells.

**Weight** 0.1 to 0.3 kg (0.5 to 1.4 lb) for standard options.

**Material** Insert diameter in SS 316L/1.4404, terminal block in ceramics.

## Certificates and approvals

**CE mark** The product meets the requirements of the harmonized European standards. As such, it complies with the legal specifications of the EC directives. The manufacturer confirms successful testing of the product by affixing to it the CE-mark.

**Ex approvals** More information on the hazardous area versions currently available (ATEX, FM, CSA, etc.) is available from your Endress+Hauser sales center. Separate Ex documentation contain all the data relevant for explosion protection.

**EAC mark** The product meets the legal requirements of the EEU guidelines. The manufacturer confirms the successful testing of the product by affixing the EAC mark.

**Other standards and guidelines**

- IEC 60751: Industrial platinum resistance thermometers
- DIN 43735: Replaceable inserts for RTDs and thermocouples

**Inspection certificates** The "Factory calibration" is carried out according to an internal procedure in a laboratory of Endress+Hauser accredited by the European Accreditation Organization (EA) to ISO/IEC 17025. A calibration which is performed according to EA guidelines (SIT/Accredia or DKD/DAkkS calibration) may be requested separately. The calibration is performed on the replaceable insert of the thermometer. In the case of thermometers without a replaceable insert, the entire thermometer - from the process connection to the tip of the thermometer - is calibrated.

**MID** Test certificate (only in SIL mode). In compliance with:

- WELMEC 8.8, "Guide on the General and Administrative Aspects of the Voluntary System of Modular Evaluation of Measuring Instruments."
- OIML R117-1 Edition 2007 (E) "Dynamic measuring systems for liquids other than water"
- EN 12405-1/A2 Edition 2010 "Gas meters - Conversion devices - Part 1: Volume conversion"
- OIML R140-1 Edition 2007 (E) "Measuring systems for gaseous fuel"

## Ordering information

Detailed ordering information is available for your nearest sales organization [www.addresses.endress.com](http://www.addresses.endress.com) or in the Product Configurator under [www.endress.com](http://www.endress.com) :

1. Click Corporate
2. Select the country
3. Click Products
4. Select the product using the filters and search field
5. Open the product page

The Configuration button to the right of the product image opens the Product Configurator.

### Product Configurator - the tool for individual product configuration

- Up-to-the-minute configuration data
- Depending on the device: Direct input of measuring point-specific information such as measuring range or operating language
- Automatic verification of exclusion criteria
- Automatic creation of the order code and its breakdown in PDF or Excel output format
- Ability to order directly in the Endress+Hauser Online Shop

## Supplementary documentation

### Technical Information

- **iTEMP temperature head transmitter:**
  - HART® TMT82, two-channel, RTD, TC, Ω, mV (TI01010T)
  - PROFIBUS® PA TMT84, two-channel, RTD, TC, Ω, mV (TI00138R)
  - FOUNDATION Fieldbus™ TMT85, two-channel, RTD, TC, Ω, mV (TI00134R)
  - TMT180, PC-programmable, single-channel, Pt100 (TI00088R)
- **Supplementary documentation ATEX/IECEX:**
  - TRxx, TCxx, TxCxx (XA00072R)
  - TRxx, TCxx, TEC420, TS111, TM211, TPx100, TSx310, TM1x1 (XA00044R)
  - iTHERM TS111, TM211, TST310, TSC310, TPR100, TPC100 (XA00100R)
  - TPx100, TSx310 (XA01421T)



[www.addresses.endress.com](http://www.addresses.endress.com)

---