

# Technical Information

## iTHERM TM411

Trend-setting, modular resistance thermometer for hygienic and aseptic applications

Easy-to-use metric version with outstanding sensor technology



### Applications

- Specially designed for use in hygienic and aseptic applications in the Food & Beverages and Life Sciences industries
- Measuring range:  $-200$  to  $+600$  °C ( $-328$  to  $+1112$  °F)
- Pressure range up to 50 bar (725 psi)
- Protection class: up to IP69K

### Head transmitter

All Endress+Hauser transmitters are available with enhanced accuracy and reliability compared to directly wired sensors. Easy customizing by choosing one of the following outputs and communication protocols:

- Analog output 4 to 20 mA, HART®
- PROFIBUS® PA, FOUNDATION Fieldbus™

### Your benefits

- User-friendly and reliable from product selection to maintenance
- iTHERM inserts: globally unique, automated production. Full traceability and consistently high product quality for reliable measured values
- iTHERM QuickSens: fastest response times ( $t_{90s}$ : 1.5 s) for optimum process control
- iTHERM StrongSens: unsurpassed vibration resistance ( $> 60g$ ) for ultimate plant safety
- iTHERM QuickNeck – cost and time savings thanks to simple, tool-free recalibration
- iTHERM TA30R: 316L terminal head for easier handling and lower installation and maintenance costs, and with highest IP69K rating
- International certification: explosion protection e.g. ATEX/IECEx and in compliance with hygiene standards according to 3-A®, EHEDG, ASME BPE, FDA, TSE Certificate of Suitability

## Table of contents

<b>Function and system design</b> . . . . .	<b>3</b>	Thermowell . . . . .	38
iTHERM Hygiene line . . . . .	3	<b>Certificates and approvals</b> . . . . .	<b>48</b>
Measuring principle . . . . .	3	CE mark . . . . .	48
Measuring system . . . . .	4	Hygiene standard . . . . .	48
Modular design . . . . .	5	Ex approval . . . . .	48
<b>Input</b> . . . . .	<b>7</b>	Other standards and guidelines . . . . .	48
Measured variable . . . . .	7	CRN approval . . . . .	48
Measuring range . . . . .	7	Areas in contact with medium . . . . .	48
<b>Output</b> . . . . .	<b>7</b>	Surface roughness . . . . .	48
Output signal . . . . .	7	Material resistance . . . . .	48
Family of temperature transmitters . . . . .	7	Material certification . . . . .	48
<b>Power supply</b> . . . . .	<b>8</b>	Calibration . . . . .	49
Wiring diagram for RTD . . . . .	8	Thermowell testing and load capacity calculation . . . . .	49
Cable entries . . . . .	9	<b>Ordering information</b> . . . . .	<b>49</b>
Device plugs . . . . .	9	<b>Accessories</b> . . . . .	<b>49</b>
Overvoltage protection . . . . .	11	Device-specific accessories . . . . .	50
<b>Performance characteristics</b> . . . . .	<b>11</b>	Communication-specific accessories . . . . .	53
Reference conditions . . . . .	11	Service-specific accessories . . . . .	54
Accuracy . . . . .	12	System components . . . . .	54
Influence of ambient temperature . . . . .	12	<b>Documentation</b> . . . . .	<b>55</b>
Self heating . . . . .	12		
Response time . . . . .	13		
Calibration . . . . .	14		
Insulation resistance . . . . .	15		
<b>Installation</b> . . . . .	<b>16</b>		
Orientation . . . . .	16		
Installation instructions . . . . .	16		
<b>Environment</b> . . . . .	<b>18</b>		
Ambient temperature range . . . . .	18		
Storage temperature . . . . .	18		
Humidity . . . . .	18		
Climate class . . . . .	18		
Degree of protection . . . . .	18		
Shock and vibration resistance . . . . .	19		
Electromagnetic compatibility (EMC) . . . . .	19		
<b>Process</b> . . . . .	<b>19</b>		
Process temperature range . . . . .	19		
Thermal shock . . . . .	19		
Process pressure range . . . . .	19		
Medium - state of aggregation . . . . .	20		
<b>Mechanical construction</b> . . . . .	<b>20</b>		
Design, dimensions . . . . .	20		
Insert . . . . .	32		
Weight . . . . .	32		
Material . . . . .	32		
Surface roughness . . . . .	33		
Terminal heads . . . . .	33		
Extension neck . . . . .	37		

## Function and system design

### iTHERM Hygiene line

This thermometer is part of the product line of modular thermometers for hygienic and aseptic applications.

*Differentiating factors when selecting a suitable thermometer*

TM4x1	TM4x2
Metric version	Imperial version



TM41x characterizes the device that uses cutting-edge technology, with features such as a replaceable insert, quick-fastening extension neck (iTHERM QuickNeck), vibration-resistant and fast-response sensor technology (iTHERM StrongSens and QuickSens) and approval for use in hazardous areas

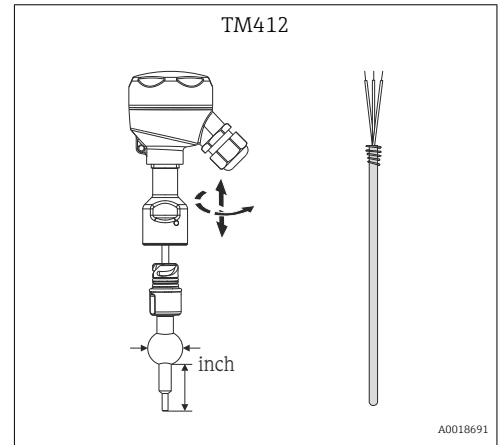
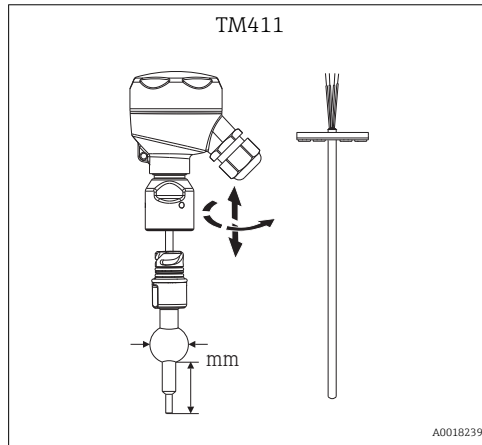

TM40x characterizes the device that uses basic technology, with features such as a fixed, non-replaceable insert, application in non-hazardous areas, standard extension neck, low-cost unit

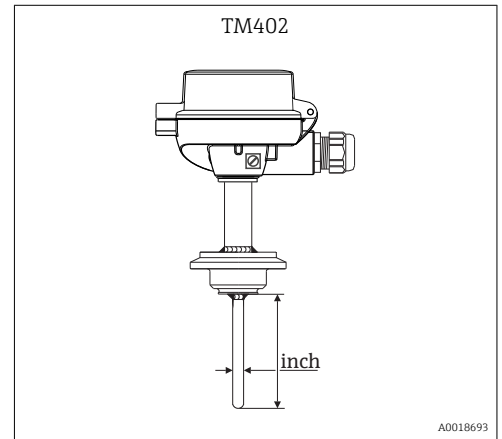
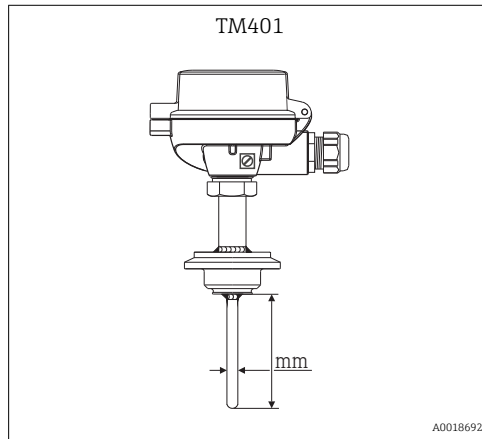

### Measuring principle

#### Resistance thermometer (RTD)

These resistance thermometers use a Pt100 temperature sensor according to IEC 60751. The temperature sensor is a temperature-sensitive platinum resistor with a resistance of 100 Ω at 0 °C (32 °F) and a temperature coefficient  $\alpha = 0.003851 \text{ } ^\circ\text{C}^{-1}$ .

There are generally two different kinds of platinum resistance thermometers:

- **Wire wound (WW):** Here, a double coil of fine, high-purity platinum wire is located in a ceramic support. This is then sealed top and bottom with a ceramic protective layer. Such resistance thermometers not only facilitate very reproducible measurements but also offer good long-term stability of the resistance/temperature characteristic within temperature ranges up to 600 °C (1 112 °F). This type of sensor is relatively large in size and it is comparatively sensitive to vibrations.
- **Thin film platinum resistance thermometers (TF):** A very thin, ultrapure platinum layer, approx. 1 µm thick, is vaporized in a vacuum on a ceramic substrate and then structured photolithographically. The platinum conductor paths formed in this way create the measuring resistance. Additional covering and passivation layers are applied and reliably protect the thin platinum layer from contamination and oxidation, even at high temperatures.

The primary advantages of thin film temperature sensors over wire wound versions are their smaller sizes and better vibration resistance. A relatively low principle-based deviation of the resistance/temperature characteristic from the standard characteristic of IEC 60751 can frequently be observed among TF sensors at high temperatures. As a result, the tight limit values of tolerance category A as per IEC 60751 can only be observed with TF sensors at temperatures up to approx. 300 °C (572 °F).

### Thermocouples (TC)

Thermocouples are comparatively simple, robust temperature sensors which use the Seebeck effect for temperature measurement: if two electrical conductors made of different materials are connected at a point, a weak electrical voltage can be measured between the two open conductor ends if the conductors are subjected to a thermal gradient. This voltage is called thermoelectric voltage or electromotive force (emf.). Its magnitude depends on the type of conducting materials and the temperature difference between the "measuring point" (the junction of the two conductors) and the "cold junction" (the open conductor ends). Accordingly, thermocouples primarily only measure differences in temperature. The absolute temperature at the measuring point can be determined from these if the associated temperature at the cold junction is known or is measured separately and compensated for. The material combinations and associated thermoelectric voltage/temperature characteristics of the most common types of thermocouple are standardized in the IEC 60584 and ASTM E230/ANSI MC96.1 standards.

### Measuring system

Endress+Hauser offers a complete portfolio of optimized components for the temperature measuring point – everything you need for the seamless integration of the measuring point into the overall facility. This includes:

- Power supply unit/barrier
- Display units
- Overvoltage protection



For more information, see the brochure 'System Components - Solutions for a Complete Measuring Point' (FA00016K/EN)

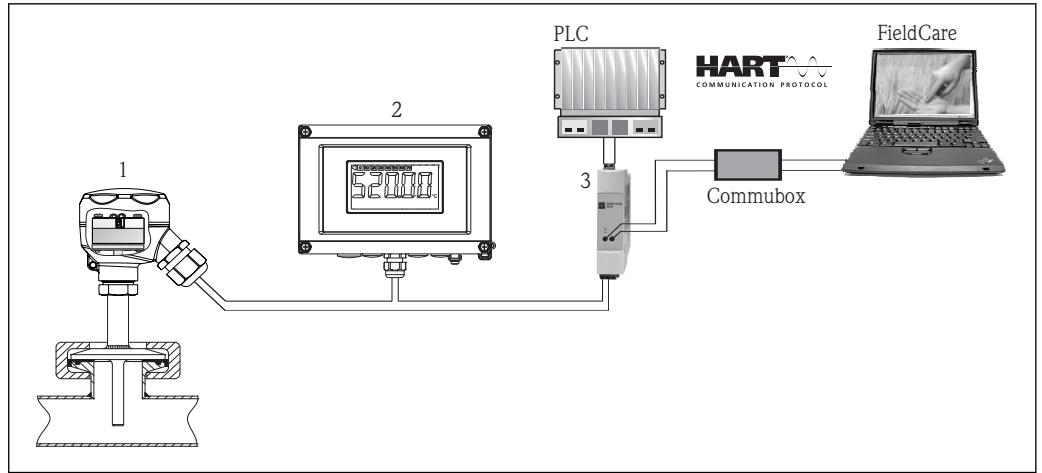



A0017693

1 Example of application, measuring point layout with additional Endress+Hauser components

- 1 Installed iTHERM resistance thermometer with integrated HART® head transmitter
- 2 RIA16 field display unit - The display unit records the analog measuring signal from the head transmitter and shows this on the display. The LC display shows the current measured value in digital form and as a bar graph indicating a limit value violation. The display unit is looped into the 4 to 20 mA circuit and gets the required energy from there. More information on this can be found in the Technical Information, see "Documentation", → 55.
- 3 Active barrier RN221N - The RN221N (24 V DC, 30 mA) active barrier has a galvanically isolated output for supplying voltage to loop-powered transmitters. The universal power supply works with an input supply voltage of 20 to 250 V DC/AC, 50/60 Hz, which means that it can be used in all international power grids. More information on this can be found in the Technical Information, see "Documentation", → 55.

Modular design

Design	Options
<p style="text-align: right; font-size: small;">A0017758</p>	<p>1: Terminal head → 33</p> <ul style="list-style-type: none"> <li>▪ 316L, low head, optionally with display window</li> <li>▪ Aluminum, high or low head, with or without display window</li> <li>▪ Polypropylene, low head</li> <li>▪ Polyamide, high head, without display window</li> </ul> <p><b>i</b> <b>Your benefits:</b></p> <ul style="list-style-type: none"> <li>▪ Optimum terminal access thanks to low housing edge of bottom section:                         <ul style="list-style-type: none"> <li>▪ Easier to use</li> <li>▪ Lower installation and maintenance costs</li> </ul> </li> <li>▪ Optional display: local process display unit for added reliability</li> <li>▪ IP69K protection: optimum protection even with high-pressure cleaning</li> </ul> <p>2: Wiring, electrical connection, output signal → 7</p> <ul style="list-style-type: none"> <li>▪ Ceramic terminal block</li> <li>▪ Flying leads</li> <li>▪ Head transmitter (4 to 20 mA, HART®, PROFIBUS® PA, FOUNDATION™ Fieldbus), single-channel or two-channel</li> <li>▪ Attachable display (optional)</li> </ul> <p>3: Connector or cable gland → 36</p> <ul style="list-style-type: none"> <li>▪ PROFIBUS® PA / FOUNDATION™ Fieldbus connector, 4-pin</li> <li>▪ 8-pin connector</li> <li>▪ Polyamide or brass cable glands</li> </ul> <p>4: Extension neck → 37</p> <p>Welded-in-place or removable either with the quick fastener (iTHERM QuickNeck) or thread adapter nut G3/8"</p> <p><b>i</b> <b>Your benefits:</b></p> <ul style="list-style-type: none"> <li>▪ iTHERM QuickNeck: tool-free removal of the insert:                         <ul style="list-style-type: none"> <li>▪ Saves time/costs on frequently calibrated measuring points</li> <li>▪ Wiring mistakes avoided</li> </ul> </li> <li>▪ IP69K protection: safety under extreme process conditions</li> </ul> <p>5: Process connection → 38</p> <p>More than 50 different versions.</p>

Design		Options
	6: Protection tube →  38	<ul style="list-style-type: none"> <li>▪ Versions with and without protection tube (insert in direct contact with process).</li> <li>▪ Various diameters</li> <li>▪ Various tip shapes (straight or reduced)</li> </ul>
	7: Insert →  32 with: 7a: iTHERM QuickSens 7b: iTHERM StrongSens	<p>Sensor models: wire wound (WW) or thin-film sensor (TF).</p> <p> <b>Your benefits:</b></p> <ul style="list-style-type: none"> <li>▪ <b>iTHERM QuickSens</b> - insert with the world's fastest response time: <ul style="list-style-type: none"> <li>▪ Insert: <math>\phi 3</math> mm (<math>\frac{1}{8}</math> in) or <math>\phi 6</math> mm (<math>\frac{1}{4}</math> in)</li> <li>▪ Fast, highly accurate measurements, delivering maximum process safety and control</li> <li>▪ Quality and cost optimization</li> <li>▪ Minimization of necessary immersion length: better product protection thanks to improved process flow</li> </ul> </li> <li>▪ <b>iTHERM StrongSens</b> - insert with unbeatable durability: <ul style="list-style-type: none"> <li>▪ Vibration resistance &gt; 60g: lower life cycle costs thanks to longer operating life and high plant availability</li> <li>▪ Automated, traceable production: top quality and maximum process safety</li> <li>▪ High long-term stability: reliable measured values and high level of system safety</li> </ul> </li> </ul>

## Input

**Measured variable** Temperature (temperature-linear transmission behavior)

**Measuring range** *Depends on the type of sensor used*

Sensor type	Measuring range
Pt100 thin-film	-50 to +400 °C (-58 to +752 °F)
Pt100 thin-film, iTHERM StrongSens, vibration-resistant > 60g	-50 to +500 °C (-58 to +932 °F)
Pt100 thin-film, iTHERM QuickSens, fast-response	-50 to +200 °C (-58 to +392 °F)
Pt100 wire wound, extended measuring range	-200 to +600 °C (-328 to +1 112 °F)

## Output

**Output signal** Generally, the measured value can be transmitted in one of two ways:

- Directly-wired sensors - sensor measured values forwarded without a transmitter.
- Via all of the usual protocols by selecting an appropriate Endress+Hauser iTEMP® temperature transmitter. All the transmitters listed below are mounted directly in the terminal head and wired with the sensory mechanism.

### Family of temperature transmitters

Thermometers fitted with iTEMP transmitters are an installation-ready complete solution to improve temperature measurement by significantly increasing accuracy and reliability, when compared to direct wired sensors, as well as reducing both wiring and maintenance costs.

#### PC programmable head transmitters

They offer a high degree of flexibility, thereby supporting universal application with low inventory storage. The iTEMP transmitters can be configured quickly and easily at a PC. Endress+Hauser offers free configuration software which can be downloaded from the Endress+Hauser Website. More information can be found in the Technical Information.

#### HART® programmable head transmitters

The transmitter is a 2-wire device with one or two measuring inputs and one analog output. The device not only transfers converted signals from resistance thermometers and thermocouples, it also transfers resistance and voltage signals using HART® communication. It can be installed as an intrinsically safe apparatus in Zone 1 hazardous areas and is used for instrumentation in the terminal head (flat face) as per DIN EN 50446. Swift and easy operation, visualization and maintenance using universal device configuration tools like FieldCare, DeviceCare or FieldCommunicator 375/475. For more information, see the Technical Information.

#### PROFIBUS® PA head transmitters

Universally programmable head transmitter with PROFIBUS® PA communication. Conversion of various input signals into digital output signals. High accuracy over the complete ambient temperature range. The configuration of PROFIBUS PA functions and of device-specific parameters is performed via fieldbus communication. For more information, see the Technical Information.

#### FOUNDATION Fieldbus™ head transmitters

Universally programmable head transmitter with FOUNDATION Fieldbus™ communication. Conversion of various input signals into digital output signals. High accuracy over the complete ambient temperature range. All transmitters are released for use in all important process control systems. The integration tests are performed in Endress+Hauser's "System World". For more information, see the Technical Information.

Advantages of the iTEMP transmitters:

- Dual or single sensor input (optionally for certain transmitters)
- Pluggable display (optionally for certain transmitters)
- Unsurpassed reliability, accuracy and long-term stability in critical processes

- Mathematical functions
- Monitoring of the thermometer drift, sensor backup functionality, sensor diagnostic functions
- Sensor-transmitter matching for dual sensor input transmitters, based on Callendar/Van Dusen coefficients

## Power supply

- i** ▪ According to the 3-A<sup>®</sup> Sanitary Standard and the EHEDG, electrical connecting cables must be smooth, corrosion-resistant and easy to clean.
- Grounding or shield connections are possible via special ground terminals on the terminal head. → 33

### Wiring diagram for RTD

Type of sensor connection

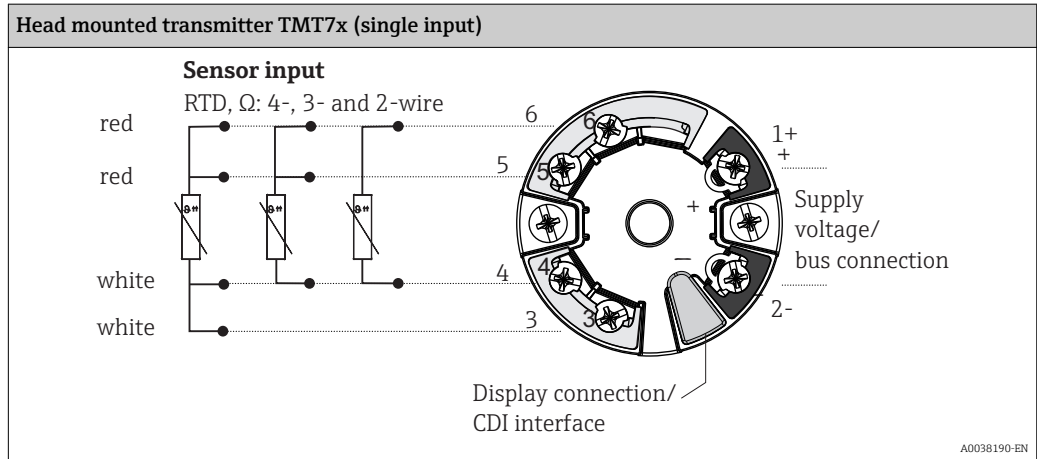
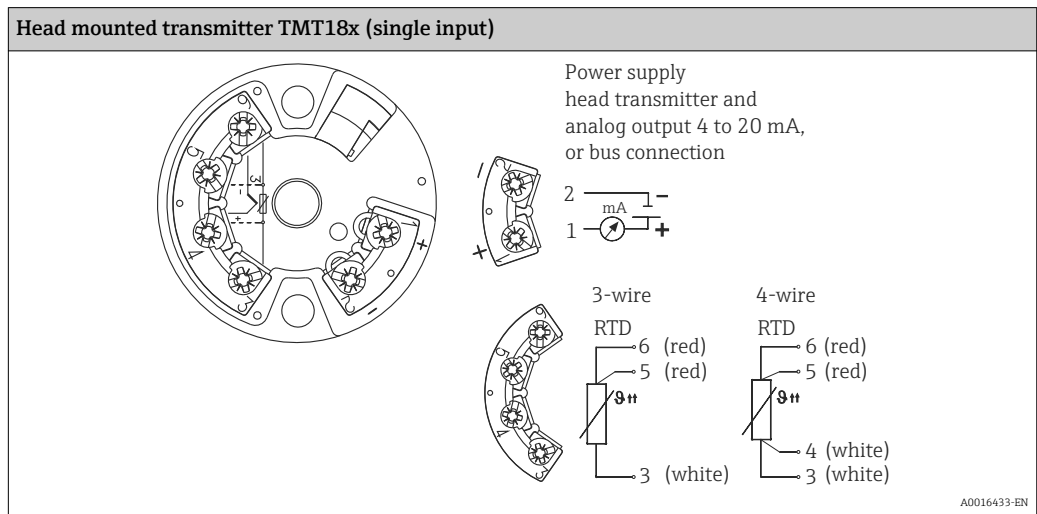



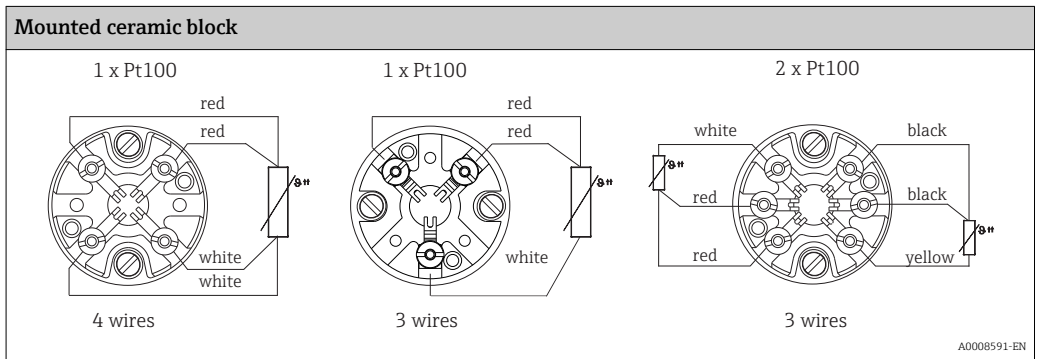
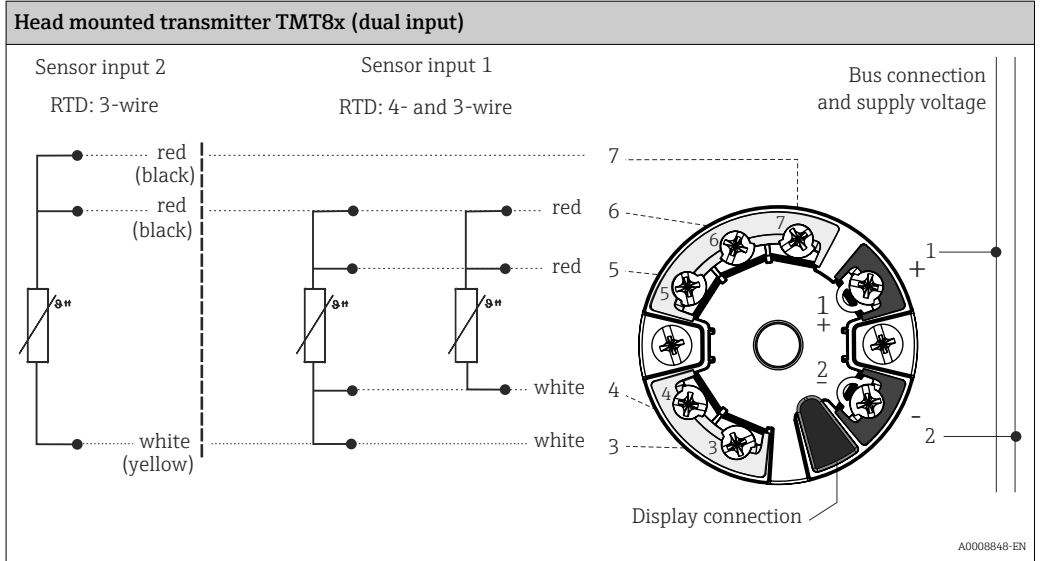

**Cable entries** See Terminal heads' section → 33

**Device plugs** Endress+Hauser offers a wide variety of connectors for the simple and fast integration of the thermometer into a process control system. The following tables show the PIN assignments of the various plug connector combinations.

*Abbreviations*

#1	Order: first transmitter/insert	#2	Order: second transmitter/insert
i	Insulated. Wires marked 'i' are not connected and are insulated with heat shrink tubes.	YE	Yellow
GND	Grounded. Wires marked 'GND' are connected to the internal grounding screw in the terminal head.	RD	Red
BN	Brown	WH	White
GNYE	Green-yellow	PK	Pink
BU	Blue	GN	Green
GY	Gray	BK	Black

*Terminal head with one cable entry*

Plug	1x PROFIBUS PA				1x FOUNDATION™ Fieldbus (FF)				8-pin											
	M12				7/8"				7/8"				M12							
PIN number	1	2	3	4	1	2	3	4	1	2	3	4	1	2	3	4	5	6	7	8

Plug	1x PROFIBUS PA								1x FOUNDATION™ Fieldbus (FF)				8-pin							
<b>Electrical connection (terminal head)</b>																				
Flying leads	Not connected (not insulated)																			
3-wire terminal block (1x Pt100)	RD	RD	WH		RD	RD	WH		RD	RD	WH		RD	RD	WH		i			
4-wire terminal block (1x Pt100)			WH	WH			WH	WH			WH	WH			WH	WH				
6-wire terminal block (2x Pt100)	RD (#1) <sub>1)</sub>	RD (#1) <sub>1)</sub>	WH (#1) <sup>1)</sup>		RD (#1) <sub>1)</sub>	RD (#1) <sub>1)</sub>	WH (#1) <sup>1)</sup>		RD (#1) <sub>1)</sub>	RD (#1) <sub>1)</sub>	WH (#1) <sup>1)</sup>				WH		BK	BK	YE	
1x TMT 4 to 20 mA or HART®	+	i	-	i	+	i	-	i	+	i	-	i			i					
2x TMT 4 to 20 mA or HART® in the terminal head with a high cover	+	+	-	-	+	+	-	-	+	+	-	-	+	i	-	i	+	i	-	i
1x TMT PROFIBUS® PA	+		-	GND <sub>2)</sub>	+		-	GND <sub>2)</sub>	Cannot be combined				Cannot be combined							
2x TMT PROFIBUS® PA	+	i	-	(#1)	+		-		Cannot be combined				Cannot be combined							
1x TMT FF	Cannot be combined				Cannot be combined				-	+	GND	i	Cannot be combined							
2x TMT FF	Cannot be combined				Cannot be combined				-	+	(#1)	(#1)	Cannot be combined							
PIN position and color code																				

- 1) Second Pt100 is not connected
- 2) If a plastic housing TA30S or TA30P is used, insulated 'i' instead of grounded GND

Terminal head with two cable entries

Plug	2x PROFIBUS® PA								2x FOUNDATION™ Fieldbus (FF)				
Plug thread  #1—#2	M12(#1) / M12(#2)				7/8"(#1) / 7/8"(#2)				7/8"(#1) / 7/8"(#2)				
PIN number	1	2	3	4	1	2	3	4	1	2	3	4	
<b>Electrical connection (terminal head)</b>													
Flying leads	Not connected (not insulated)												
3-wire terminal block (1x Pt100)	RD/i	RD/i	WH/i		RD/i	RD/i	WH/i		RD/i	RD/i	WH/i		
4-wire terminal block (1x Pt100)			WH/i	WH/i			WH/i	WH/i			WH/i	WH/i	
6-wire terminal block (2x Pt100)	RD/BK	RD/BK	WH/YE		RD/BK	RD/BK	WH/YE		RD/BK	RD/BK	WH/YE		
1x TMT 4 to 20 mA or HART®	+/i		-/i		+/i		-/i		+/i		-/i		
2x TMT 4 to 20 mA or HART® in the terminal head with a high cover	+(#1)/ +(#2)	i/i	-(#1)/ -(#2)	i/i	+(#1)/ +(#2)	i/i	-(#1)/ -(#2)	i/i	+(#1)/ +(#2)	i/i	-(#1)/ -(#2)	i/i	

Plug	2x PROFIBUS® PA								2x FOUNDATION™ Fieldbus (FF)			
	+/i		-/i	GND/G ND	+/i		-/i	GND/G ND	Cannot be combined			
1x TMT PROFIBUS® PA												
2x TMT PROFIBUS® PA	+(#1)/ +(#2)		-(#1)/ -(#2)		+(#1)/ +(#2)		-(#1)/ -(#2)					
1x TMT FF	Cannot be combined				Cannot be combined				-/i	+/i	i/i	GND/G ND
2x TMT FF									-(#1)/ -(#2)	+(#1)/ +(#2)		
PIN position and color code	 <small>A0018929</small>				 <small>A0018930</small>				 <small>A0018931</small>			

Connection combination: insert - transmitter

Insert	Transmitter connection <sup>1)</sup>			
	TMT180/TMT181/TMT182/TMT71/TMT72		TMT82/TMT84/TMT85	
	1x 1-channel	2x 1-channel <sup>2)</sup>	1x 2-channel	2x 2-channel <sup>2)</sup>
1x Pt100, flying leads	Pt100 (#1) : transmitter (#1)	Pt100 (#1) : transmitter (#1) (Transmitter (#2) not connected)	Pt100 (#1) : transmitter (#1)	Pt100 (#1) : transmitter (#1) Transmitter (#2) not connected
2x Pt100, flying leads	Pt100 (#1) : transmitter (#1) Pt100 (#2) insulated	Pt100 (#1) : transmitter (#1) Pt100 (#2) : transmitter (#2)	Pt100 (#1) : transmitter (#1) Pt100 (#2) : transmitter (#1)	Pt100 (#1) : transmitter (#1) Pt100 (#2) : transmitter (#1) (Transmitter (#2) not connected)
1x Pt100 with terminal block <sup>2)</sup>	Pt100 (#1) : transmitter in cover	Cannot be combined	Pt100 (#1) : transmitter in cover	Cannot be combined
2x Pt100 with terminal block <sup>2)</sup>	Pt100 (#1) : transmitter in cover Pt100 (#2) not connected		Pt100 (#1) : transmitter in cover Pt100 (#2) : transmitter in cover	

- 1) If 2 transmitters are selected in a terminal head, transmitter (#1) is installed directly on the insert. Transmitter (#2) is installed in the high cover. A TAG cannot be ordered for the 2nd transmitter as standard. The bus address is set to the default value and, if necessary, must be changed manually before commissioning.
- 2) Only in the terminal head with a high cover, only 1 transmitter possible. A ceramic terminal block is automatically fitted on the insert.

**Overvoltage protection**

To protect against overvoltage in the power supply and signal/communication cables for the thermometer electronics, Endress+Hauser offers the HAW562 surge arrester for DIN rail mounting and the HAW569 for field housing installation.



For more information see the Technical Information 'HAW562 Surge arrester' TI01012K and 'HAW569 Surge arrester' TI01013K.

## Performance characteristics

**Reference conditions**

These data are relevant for determining the accuracy of the temperature transmitters used. More information on this can be found in the Technical Information of the iTEMP temperature transmitters. → 55

**Accuracy** RTD resistance thermometer as per IEC 60751

Class	Max. tolerances (°C)	Characteristics	
Cl. AA, former 1/3 Cl. B	$\pm (0.1 + 0.0017 \cdot  t ^{1})$		
Cl. A	$\pm (0.15 + 0.002 \cdot  t )$		
Cl. B	$\pm (0.3 + 0.005 \cdot  t )$		
<b>Temperature ranges for compliance with the tolerance classes</b>			
Wire wound sensor (WW):	Cl. A	Cl. AA	
	- 100 to +450 °C	-50 to +250 °C	
Thin-film version (TF):	Cl. A	Cl. AA	
	Standard	-30 to +300 °C	0 to +150 °C
	iTHERM QuickSens	-30 to +200 °C	0 to +150 °C
	iTHERM StrongSens	-30 to +300 °C	0 to +150 °C

1) |t| = absolute value °C

 In order to obtain the maximum tolerances in °F, the results in °C must be multiplied by a factor of 1.8.

**Influence of ambient temperature** Depends on the head transmitter used. For details, see Technical Information. →  55

**Self heating** RTD elements are passive resistances that are measured using an external current. This measurement current causes a self-heating effect in the RTD element itself which in turn creates an additional measurement error. In addition to the measurement current, the size of the measurement error is also affected by the temperature conductivity and flow velocity of the process. This self-heating error is negligible when an Endress+Hauser iTHERM temperature transmitter (very low measured current) is used.

**Response time** Tests in water at 0.4 m/s (1.3 ft/s), according to IEC 60751; 10 K temperature step change.

*Response time with heat transfer paste <sup>1)</sup>*

Thermowell	Shape of tip	Insert	1x Pt100 iTHERM QuickSens, TF		1x Pt100 iTHERM StrongSens, TF		1x Pt100 wire wound WW		2x Pt100 wire wound WW		1x Pt100 standard thin-film TF	
			t <sub>50</sub>	t <sub>90</sub>	t <sub>50</sub>	t <sub>90</sub>	t <sub>50</sub>	t <sub>90</sub>	t <sub>50</sub>	t <sub>90</sub>	t <sub>50</sub>	t <sub>90</sub>
Without thermowell	-	Ø6 mm (¼ in)	0.5 s	1.5 s	2.5 s	9.5 s	4 s	11.5 s	4.5 s	12 s	4.75 s	13 s
Ø6 mm (¼ in)	Reduced 4.3 mm (0.17 in)x 20 mm (0.79 in)	Ø3 mm (⅛ in)	1 s	2.5 s	-		8.5 s	26 s	5.5 s	18 s	8 s	23 s
Ø9 mm (0.35 in)	Straight	Ø6 mm (¼ in)	2 s	9 s	8 s	27 s	15 s	45 s	15 s	45 s	9.5 s	27 s
	Reduced 5.3 mm (0.21 in)x 20 mm (0.79 in)	Ø3 mm (⅛ in)	1.25 s	4 s	-		7 s	20 s	7 s	20 s	7 s	23 s
	Tapered 6.6 mm (0.26 in) x 60 mm (2.36 in)	Ø3 mm (⅛ in)	2.5 s	12 s	-		14 s	49 s	12 s	40 s	15 s	51 s
Ø12.7 mm (½ in)	Straight	Ø6 mm (¼ in)	4 s	26 s	12 s	54 s	23 s	81 s	23 s	81 s	31 s	100 s
	Reduced 5.3 mm (0.21 in)x 20 mm (0.79 in)	Ø3 mm (⅛ in)	1.5 s	5.5 s	-		9 s	27 s	9 s	27 s	6.5 s	21 s
	Reduced 8 mm (0.31 in)x 32 mm (1.26 in)	Ø6 mm (¼ in)	6 s	36 s	11 s	44 s	22 s	69 s	22 s	69 s	26 s	90 s

1) If using a thermowell.

*Response time without heat transfer paste <sup>1)</sup>*

Thermowell	Shape of tip	Insert	1x Pt100 iTHERM QuickSens, TF		1x Pt100 iTHERM StrongSens, TF		1x Pt100 wire wound WW		2x Pt100 wire wound WW		1x Pt100 standard thin-film TF	
			t <sub>50</sub>	t <sub>90</sub>	t <sub>50</sub>	t <sub>90</sub>	t <sub>50</sub>	t <sub>90</sub>	t <sub>50</sub>	t <sub>90</sub>	t <sub>50</sub>	t <sub>90</sub>
Without thermowell	-	Ø3 mm (⅛ in)	0.5 s	0.75 s	-		1.75 s	5 s	2 s	6 s	2.5 s	5.5 s
		Ø6 mm (¼ in)		1.5 s	2.5 s	9.5 s	4 s	11.5 s	4.5 s	12 s	4.75 s	13 s
Ø6 mm (¼ in)	Reduced 4.3 mm (0.17 in)x 20 mm (0.79 in)	Ø3 mm (⅛ in)	1 s	3 s	-		9 s	27 s	7.5 s	24 s	8.5 s	28 s
Ø9 mm (0.35 in)	Straight	Ø6 mm (¼ in)	2 s	9 s	8 s	29 s	19 s	62 s	19 s	62 s	13.5 s	42 s
	Reduced 5.3 mm (0.21 in)x 20 mm (0.79 in)	Ø3 mm (⅛ in)	1.5 s	5 s	-		7 s	21 s	7 s	21 s	8 s	22 s
	Tapered 6.6 mm (0.26 in) x 60 mm (2.36 in)	Ø3 mm (⅛ in)	5 s	23 s	-		13 s	45 s	13 s	45 s	15.5 s	60 s
Ø12.7 mm (½ in)	Straight	Ø6 mm (¼ in)	5.5 s	41 s	12 s	54 s	23 s	82 s	23 s	82 s	32 s	105 s
	Reduced 5.3 mm (0.21 in)x 20 mm (0.79 in)	Ø3 mm (⅛ in)	2 s	6 s	-		10 s	30 s	10 s	30 s	8 s	30 s
	Reduced 8 mm (0.31 in)x 32 mm (1.26 in)	Ø6 mm (¼ in)	14.5 s	65 s	16 s	53 s	26 s	85 s	26 s	85 s	32 s	108 s

1) If using a thermowell.



Response time for directly wired insert without transmitter.

## Calibration

### Calibration of thermometers

Calibration involves comparing the measured values of a device under test (DUT) with those of a more precise calibration standard using a defined and reproducible measurement method. The aim is to determine the deviation of the DUT's measured values from the true value of the measured variable. Two different methods are used for thermometers:

- Calibration at fixed-point temperatures, e.g. at the freezing point of water at 0 °C,
- Calibration compared against a precise reference thermometer.

The thermometer to be calibrated must display the fixed point temperature or the temperature of the reference thermometer as accurately as possible. Temperature-controlled calibration baths with very homogeneous thermal values, or special calibration furnaces are typically used for thermometer calibrations. The measuring uncertainty may increase due to heat conduction errors and short immersion lengths. The existing measuring uncertainty is recorded on the individual certificate of calibration. For accredited calibrations in accordance with ISO17025, a measuring uncertainty that is twice as high as the accredited measuring uncertainty is not permitted. If this limit is exceeded, only a factory calibration is possible.

### Evaluation of thermometers

If a calibration with an acceptable uncertainty of measurement and transferable measurement results is not possible, Endress+Hauser offers customers a thermometer evaluation measurement service, if technically feasible. This is the case when:

- The process connections/flanges are too big or the immersion length (IL) is too short to allow the DUT to be immersed sufficiently in the calibration bath or furnace (see the following table), or
- Due to heat conduction along the thermometer tube, the resulting sensor temperature generally deviates significantly from the actual bath/furnace temperature.

The measured value of the DUT is determined using the maximum possible immersion depth and the specific measuring conditions and measurement results are documented on an evaluation certificate.

### Sensor transmitter matching

The resistance/temperature curve of platinum resistance thermometers is standardized but in practice it is rarely possible to keep to the values precisely over the entire operating temperature range. For this reason, platinum resistance sensors are divided into tolerance classes, such as Class A, AA or B as per IEC 60751. These tolerance classes describe the maximum permissible deviation of the specific sensor characteristic curve from the standard curve, i.e. the maximum temperature-dependent characteristic error that is permitted. The conversion of measured sensor resistance values to temperatures in temperature transmitters or other meter electronics is often susceptible to considerable errors as the conversion is generally based on the standard characteristic curve.

When using E+H temperature transmitters, this conversion error can be reduced significantly by sensor-transmitter matching:

- Calibration at three temperatures at least and determination of the actual temperature sensor characteristic curve,
- Adjustment of the sensor-specific polynomial function using Calendar-van Dusen (CvD) coefficients,
- Configuration of the temperature transmitter with the sensor-specific CvD coefficients for resistance/temperature conversion, and
- another calibration of the reconfigured temperature transmitter with connected resistance thermometer.

Endress+Hauser offers its customers this kind of sensor-transmitter matching as a separate service. Furthermore, the sensor-specific polynomial coefficients of platinum resistance thermometers are always provided on every Endress+Hauser calibration certificate where possible, e.g. at least three calibration points, so that users themselves can also appropriately configure suitable temperature transmitters.

For the device, Endress+Hauser offers standard calibrations at a reference temperature of -80 to +600 °C (-112 to +1 112 °F) based on the ITS90 (International Temperature Scale). Calibrations in other temperature ranges are available from your Endress+Hauser sales center on request. Calibrations are traceable to national and international standards. The calibration certificate is referenced to the serial number of the device. Only the insert is calibrated.

### Minimum insertion length (IL) for inserts required to perform a correct calibration

 Due to the limitations of furnace geometries, the minimum insertion lengths must be observed at high temperatures to enable a calibration to be performed with an acceptable degree of measuring uncertainty. The same applies when using a head transmitter. Due to heat conduction, minimum lengths must be observed in order to guarantee the functionality of the transmitter -40 to +85 °C (-40 to 185 °F)

Calibration temperature	Minimum insertion length IL in mm without head transmitter
-196 °C (-320.8 °F)	120 mm (4.72 in) <sup>1)</sup>
-80 to 250 °C (-112 to 482 °F)	No minimum insertion length required <sup>2)</sup>
251 to 550 °C (483.8 to 1022 °F)	300 mm (11.81 in)
551 to 600 °C (1023.8 to 1112 °F)	400 mm (15.75 in)

- 1) Min. 150 mm (5.91 in) is required
- 2) At a temperature of +80 to +250 °C (+176 to +482 °F) and with TMT, min. 50 mm (1.97 in) is required

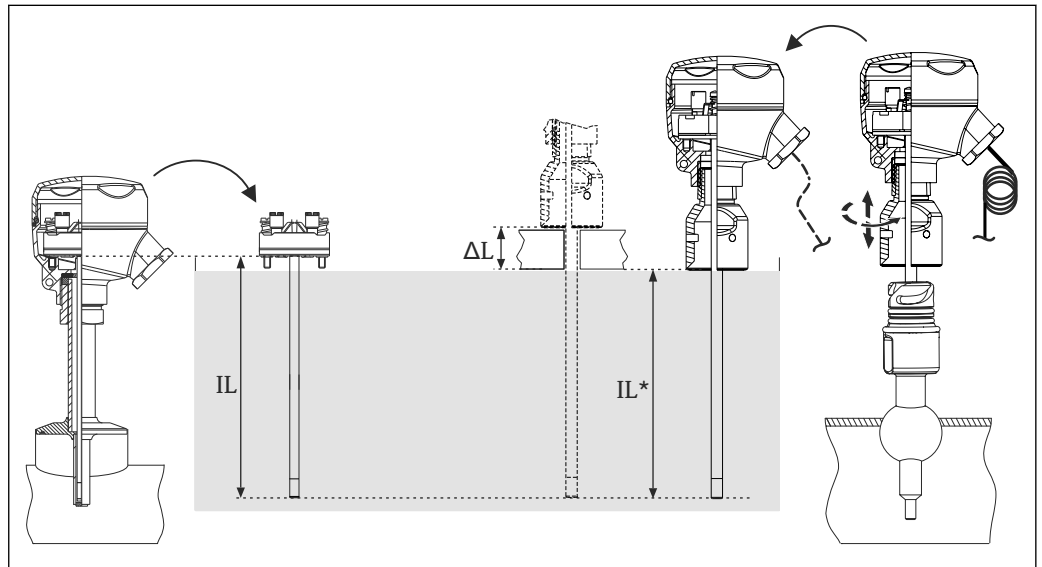

2 Insertion lengths for sensor calibration

IL Maximum possible insertion length for factory calibration or recalibration onsite without the iTHERM QuickNeck extension neck

IL\* Maximum possible insertion length for recalibration onsite with the iTHERM QuickNeck extension neck

ΔL Additional length, depending on the calibration unit, if the insert cannot be fully immersed

- To check the actual accuracy rating of the thermometers installed, a cyclic calibration of the installed sensor is frequently performed. The insert is normally removed for comparison with a precise reference thermometer in the calibration bath (see graphic, left part).
  - The iTHERM QuickNeck enables quick, tool-free removal of the insert for calibration purposes. The entire upper part of the thermometer is released by turning the terminal head. The insert is removed from the thermowell and directly immersed into the calibration bath (see graphic, right part). Make sure that the cable is long enough to be able to reach the mobile calibration bath with the cable connected. If this is not possible for the calibration, it is advisable to use a connector.
- 36

Advantages of iTHERM QuickNeck:

- Considerable time savings when recalibrating the device (up to 20 minutes per measuring point)
- Wiring mistakes avoided when re-installing
- Minimum plant downtime, thereby saving costs

Formulas for calculating the IL\* when recalibrating onsite with iTHERM QuickNeck

Version, with M24x1.5 or NPT ½" thread to terminal head	Formula
Thermowell diameter 6 mm (¼ in)	IL* = U + T + 5 mm (0.2 in)
Thermowell diameter 9 mm (0.35 in)	IL* = U + T - 25 mm (0.98 in)
Thermowell diameter 12.7 mm (½ in)	IL* = U + T + 5 mm (0.2 in)

**Insulation resistance**

Insulation resistance ≥ 100 MΩ at ambient temperature, measured between the terminals and the outer jacket with a minimum voltage of 100 V<sub>DC</sub>.

## Installation

### Orientation

No restrictions. However, self-draining in the process must be guaranteed. If there is an opening to detect leaks at the process connection, this opening must be at the lowest possible point.

### Installation instructions

The immersion length of the thermometer can influence the accuracy. If the immersion length is too small then errors in the measurement are caused by heat conduction via the process connection and the container wall. If installing into a pipe then the immersion length should ideally be half of the pipe diameter.

- Installation possibilities: Pipes, tanks or other plant components
- To minimize the error caused by heat conduction, a minimum immersion length is recommended depending on the type of sensor used and the design of the insert. This immersion depth corresponds to the minimum insertion length for the calibration.
- ATEX certification: Observe the installation instructions in the Ex documentation! → 55

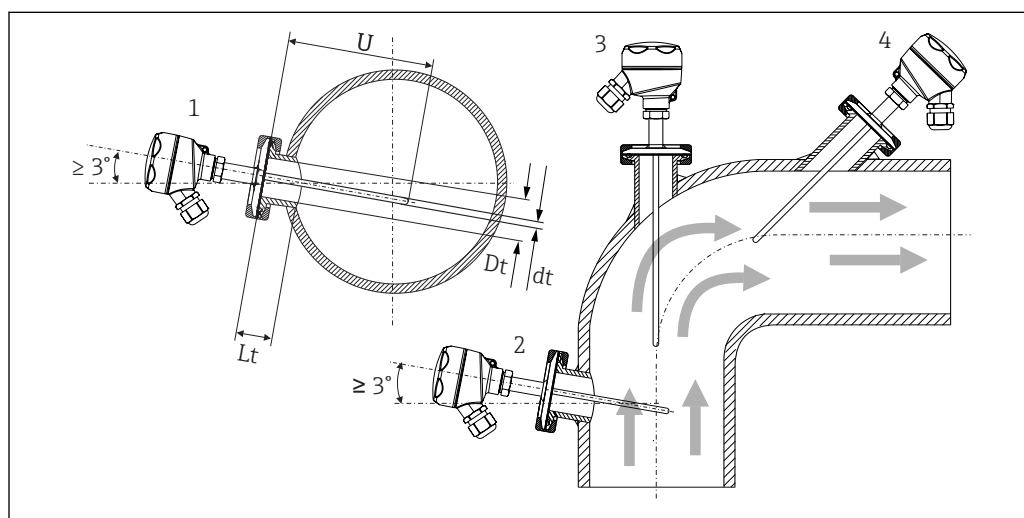

A0008946

#### 3 Installation examples

- 1, 2 Perpendicular to flow direction, installed at a min. angle of 3° to ensure self-draining  
 3 On elbows  
 4 Inclined installation in pipes with a small nominal diameter  
 U Immersion length

**i** In the case of pipes with a small nominal diameter, it is advisable for the tip of the thermometer to project well into the process so that it extends past the pipe axis. Installation at an angle (4) could be another solution. When determining the immersion length or installation depth all the parameters of the thermometer and of the medium to be measured must be taken into account (e.g. flow velocity, process pressure).

**i** The requirements of the EHEDG and the 3-A Sanitary Standard must be adhered to.

Installation instructions EHEDG/cleanability:  $L_t \leq (D_t - d_t)$

Installation instructions 3-A/cleanability:  $L_t \leq 2(D_t - d_t)$

Pay attention to the exact position of the sensor element in the thermometer tip.



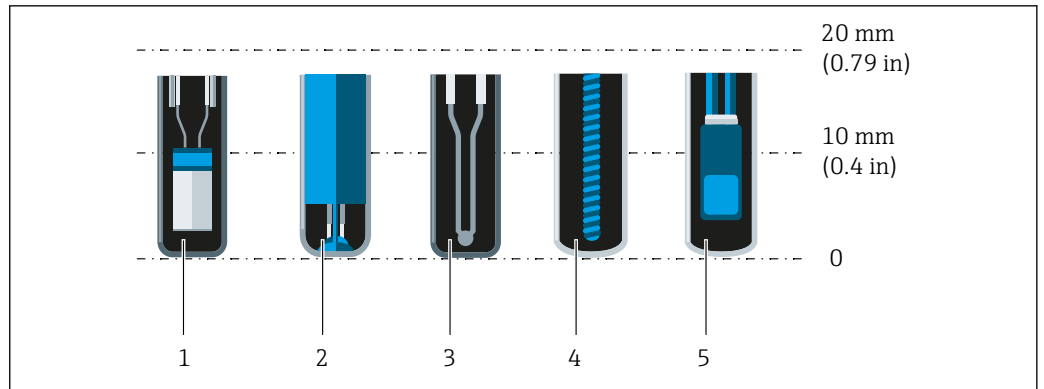

A0041814

- 1 StrongSens or TrustSens at 5 to 7 mm (0.2 to 0.28 in)
- 2 QuickSens at 0.5 to 1.5 mm (0.02 to 0.06 in)
- 3 Thermocouple (not grounded) at 3 to 5 mm (0.12 to 0.2 in)
- 4 Wire wound sensor at 5 to 20 mm (0.2 to 0.79 in)
- 5 Standard thin-film sensor at 5 to 10 mm (0.2 to 0.39 in)

To keep the influence of heat dissipation to a minimum and to achieve the best possible measurement results, 20 to 25 mm (0.79 to 0.98 in) should be in contact with the medium in addition to the actual sensor element.

This results in the following recommended minimum immersion lengths

- TrustSens or StrongSens 30 mm (1.18 in)
- QuickSens 25 mm (0.98 in)
- Wire wound sensor 45 mm (1.77 in)
- Standard thin-film sensor 35 mm (1.38 in)

It is particularly important to take this into consideration for T-pieces, as the immersion length is very short on account of their design, and the measured error is higher as a result. It is therefore recommended to use elbow pieces with QuickSens sensors.

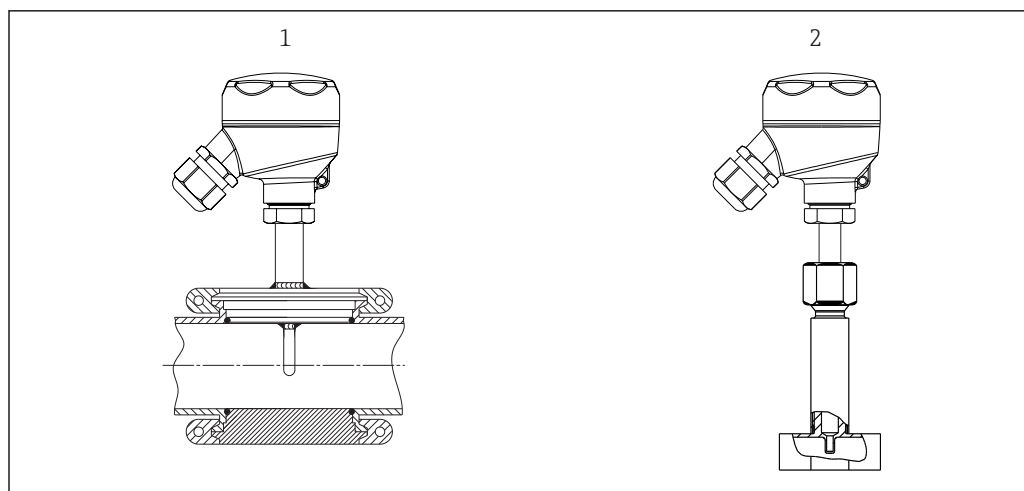

A0041794

4 Process connections for thermometer installation in pipes with small nominal diameters

1 Varivent® process connection type N for DN40

2 Elbow piece or T-piece (illustrated) for weld-in as per DIN 11865 / ASME BPE

**i** The counterpieces for the process connections and the seals or sealing rings are not included in the scope of supply for the thermometer. Liquiphant M weld-in adapters with associated seal kits are available as accessories. → 49.

As a general rule, the thermometers should be installed in such a way that does not impact their ability to be cleaned (the requirements of the 3-A® Standard must be observed). The Varivent®, Liquiphant M weld-in adapter and Ingold (+ weld-in adapter) connections enable flush-mounted installation.

**b** For the requirements for installation according to the EHEDG and 3-A Sanitary Standard, see the Operating Instructions for the modular hygienic thermometers.

Operating Instructions BA02023T

## Environment

### Ambient temperature range

Terminal head	Temperature in °C (°F)
Without mounted head transmitter	Depends on the terminal head used and the cable gland or fieldbus connector, see 'Terminal heads' section → 33
With mounted head transmitter	-40 to 85 °C (-40 to 185 °F)
With mounted head transmitter and display	-20 to 70 °C (-4 to 158 °F)

Extension neck	Temperature in °C (°F)
iTHERM QuickNeck	-50 to +140 °C (-58 to +284 °F)

### Storage temperature

For information, see the ambient temperature.

### Humidity

Depends on the transmitter used. If using Endress+Hauser iTEMP head transmitters:

- Condensation permitted as per IEC 60 068-2-33
- Max. rel. humidity: 95% as per IEC 60068-2-30

### Climate class

As per EN 60654-1, Class C

### Degree of protection

Max. IP69K, depending on the design (terminal head, connector, etc.)

**Shock and vibration resistance**

The Endress+Hauser inserts meet the requirements of IEC 60751 which specify shock and vibration resistance of 3g in the range from 10 to 500 Hz. The vibration resistance at the measuring point depends on the sensor type and design, see the following table:

Version	Vibration resistance for the sensor tip
Pt100 (WW or TF)	30 m/s <sup>2</sup> (3g) <sup>1)</sup>
iTHERM StrongSens Pt100 (TF) iTHERM QuickSens Pt100 (TF), version: ø6 mm (0.24 in)	> 600 m/s <sup>2</sup> (60g)

1) Vibration resistance also applies to quick-fastening iTHERM QuickNeck.

**Electromagnetic compatibility (EMC)**

Depends on the head transmitter used. For details see the Technical Information. →  55

## Process

**Process temperature range**

Depends on the type of sensor used, maximum -200 to +600 °C (-328 to +1 112 °F).

**Thermal shock**

Thermal shock resistance in CIP/SIP process with a temperature increase and decrease from +5 to +130 °C (+41 to +266 °F) within 2 seconds.

**Process pressure range**

The maximum possible process pressure depends on various influencing factors, such as the design, process connection and process temperature. For information on the maximum possible process pressures for the individual process connections, see the 'Process connection' section. →  38



It is possible to check the mechanical loading capacity as a function of the installation and process conditions online in the TW Sizing Module for protection tubes in the Endress+Hauser Applicator software. This is valid for DIN thermowell calculations. See 'Accessories' section. →  54

**Example of the permitted flow velocity depending on the immersion length and process medium**

The highest flow velocity tolerated by the thermometer diminishes with increasing insert immersion length exposed to the stream of the fluid. In addition it is dependent on the diameter of the thermometer tip, on the kind of measuring medium, on the process temperature and on the process pressure. The following figures exemplify the maximum permitted flow velocities in water and superheated steam at a process pressure of 40 bar (580 PSI).

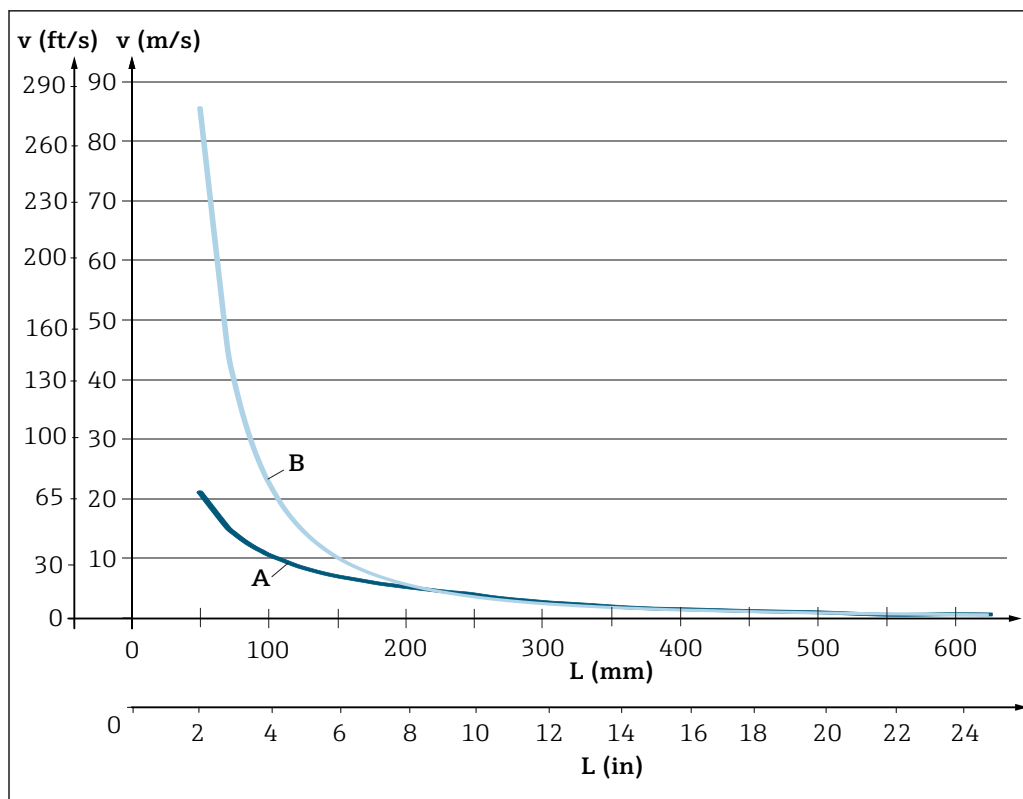

5 Permitted flow velocities, protection tube diameter 9 mm (0.35 in)

- A Medium water at  $T = 50\text{ °C}$  ( $122\text{ °F}$ )
- B Medium superheated steam at  $T = 160\text{ °C}$  ( $320\text{ °F}$ )
- L Immersion length exposed to flow
- v Flow velocity

Medium - state of aggregation

Gaseous or liquid (also with high viscosity, e.g. yogurt).

## Mechanical construction

### Design, dimensions

All dimensions in mm (in). The design of the thermometer depends on the thermowell version used:

- Thermometer without a thermowell
- Diameter 6 mm ( $\frac{1}{4}$  in)
- Diameter 9 mm (0.35 in)
- Diameter 12.7 mm ( $\frac{1}{2}$  in)
- T-piece and elbow piece thermowell version as per DIN 11865 / ASME BPE for weld-in

**i** Various dimensions, such as the immersion length U for example, are variable values and are therefore indicated as items in the following dimensional drawings.

Variable dimensions:

Item	Description
E	Extension neck length, variable depending on configuration or optionally predefined for version with iTHERM QuickNeck
IL	Insertion length of insert
L	Thermowell length (U+T)
B	Thermowell base thickness: predefined, depends on thermowell version (see also the individual table data)
T	Length of thermowell shaft: variable or predefined, depends on thermowell version (see also the individual table data)

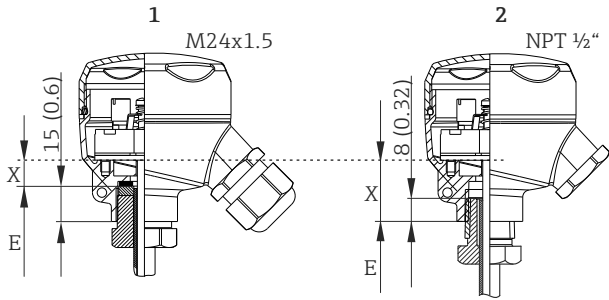
Item	Description
U	Immersion length: variable, depending on the configuration
X	Variable for calculating the insertion length of the insert, depending on different screw-in lengths in terminal head thread M24x1.5 or 1/2" NPT, see insert length calculation (IL) → 32
	 <p>6 Different screw-in lengths in terminal head thread for M24x1.5 and 1/2" NPT</p> <p>1 Thread M24x1.5: X = 11 mm (0.43 in), mat.: 1.4305 (coupling)</p> <p>2 Thread NPT 1/2": X = 26 mm (1.02 in) or with terminal head TA30S = 31 mm (1.22 in), mat.: 1.4305 (coupling)</p>
ØID	Insert diameter 6 mm (1/4 in) or 3 mm (1/8 in)

**Without thermowell**

For installation in an existing thermowell

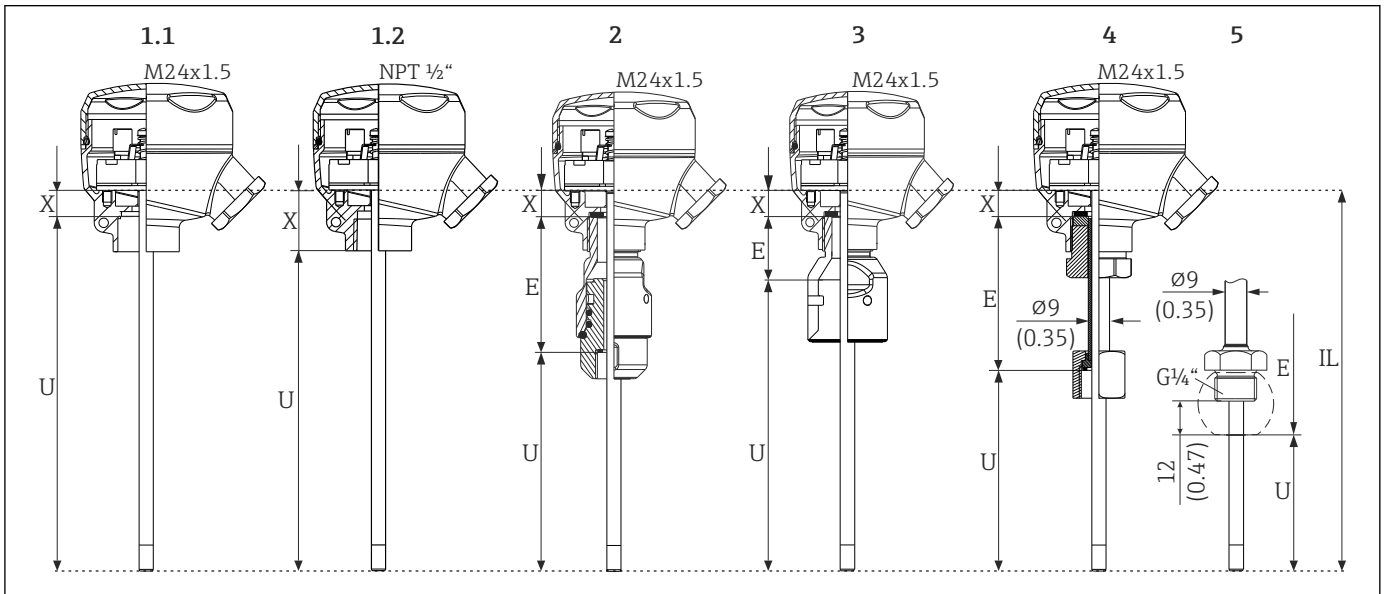

- 1.1 Thermometer without extension neck, insert surface not specified, product structure: feature 80, option A0; X = 11 mm (0.43 in) for connection thread M24x1.5
- 1.2 Thermometer without extension neck, insert surface not specified, product structure: feature 80, option A0; X = 26 mm (1.02 in) for connection thread 1/2" NPT; X = 31 mm (1.22 in) for connection thread 1/2" NPT and TA30S terminal head
- 2 Thermometer with quick-fastening iTHERM QuickNeck, top and bottom part, G3/8" internal thread for thermowell connection
- 3 Thermometer with quick-fastening iTHERM QuickNeck, top part
- 4 Thermometer with replaceable extension neck TE411, G3/8" thread adapter nut for thermowell connection
- 5 Thermometer with replaceable extension neck TE411, external thread G1/4" for compression fitting TK40

 Can be selected for all versions: thread M24x1.5 or 1/2" NPT to terminal head

Pay attention to the following equations when calculating the immersion length  $U$  for immersion into a thermowell TT411 already available:

Version 1	$U = L^{1)} + E^{2)} + 3 \text{ mm (0.12 in) - B}$
Version 2 and 4	$U = L^{1)} + 3 \text{ mm (0.12 in) - B}$
Version 3, thermowell diameter 9 mm (0.35 in)	$U = L^{1)} + 3 \text{ mm (0.12 in) (for spring travel) - B}$
Version 3, thermowell diameter 6 mm (1/4 in) / 12.7 mm (1/2 in)	$U = L^{1)} + 36 \text{ mm (1.42 in) + 3 mm (0.12 in) (for spring travel) - B}$
Version 5	$U = U_{(\text{incl. TK40})}$

- 1)  $L$  = Overall length of the thermowell available at point of installation =  $U_{\text{thermowell}} + T_{\text{thermowell}}$   
 2)  $E$  = Length of the extension neck available at point of installation (provided one is available)

Item (see drawing above)	Version	Length
Extension neck length E	<b>Version 1:</b> Without extension neck	$E = 0$
	<b>Version 2:</b> iTHERM QuickNeck with thread M24x1.5 to terminal head <ul style="list-style-type: none"> <li>▪ A0: E not required</li> <li>▪ X1: E= variable length</li> </ul>	<ul style="list-style-type: none"> <li>▪ 62 mm (2.44 in)</li> <li>▪ Variable, depending on the configuration</li> </ul>
	iTHERM QuickNeck with thread NPT 1/2" to terminal head <ul style="list-style-type: none"> <li>▪ A0: E not required</li> <li>▪ X1: E= variable length</li> </ul>	<ul style="list-style-type: none"> <li>▪ 51 mm (2.00 in)</li> <li>▪ Variable, depending on the configuration</li> </ul>
	<b>Version 3:</b> iTHERM QuickNeck top part with thread M24x1.5 to terminal head <ul style="list-style-type: none"> <li>▪ A0: E not required</li> <li>▪ X1: E= variable length</li> </ul>	<ul style="list-style-type: none"> <li>▪ 28 mm (1.1 in)</li> <li>▪ Variable, depending on the configuration</li> </ul>
	iTHERM QuickNeck top part with thread NPT 1/2" to terminal head <ul style="list-style-type: none"> <li>▪ A0: E not required</li> <li>▪ X1: E= variable length</li> </ul>	<ul style="list-style-type: none"> <li>▪ 19.5 mm (0.77 in)</li> <li>▪ Variable, depending on the configuration</li> </ul>
	<b>Version 4:</b> with replaceable extension neck, G3/8" thread adapter nut for thermowell connection	Variable, depending on the configuration
	<b>Version 5:</b> With replaceable extension neck and external thread G3/4" for compression fitting TK40, with thread M24x1.5 or 1/2" NPT to terminal head	70 mm (2.76 in)
Immersion length U	Independent of the version	Variable, depending on the configuration
Variable length X	<ul style="list-style-type: none"> <li>▪ Connection thread M24x1.5</li> <li>▪ Connection thread 1/2" NPT</li> <li>▪ Connection thread 1/2" NPT and terminal head TA30S</li> </ul> $IL = U+E+X$	11 mm (0.43 in) 26 mm (1.02 in) 31 mm (1.22 in)

With compression fitting TK40 as process connection, insert in direct contact with the process

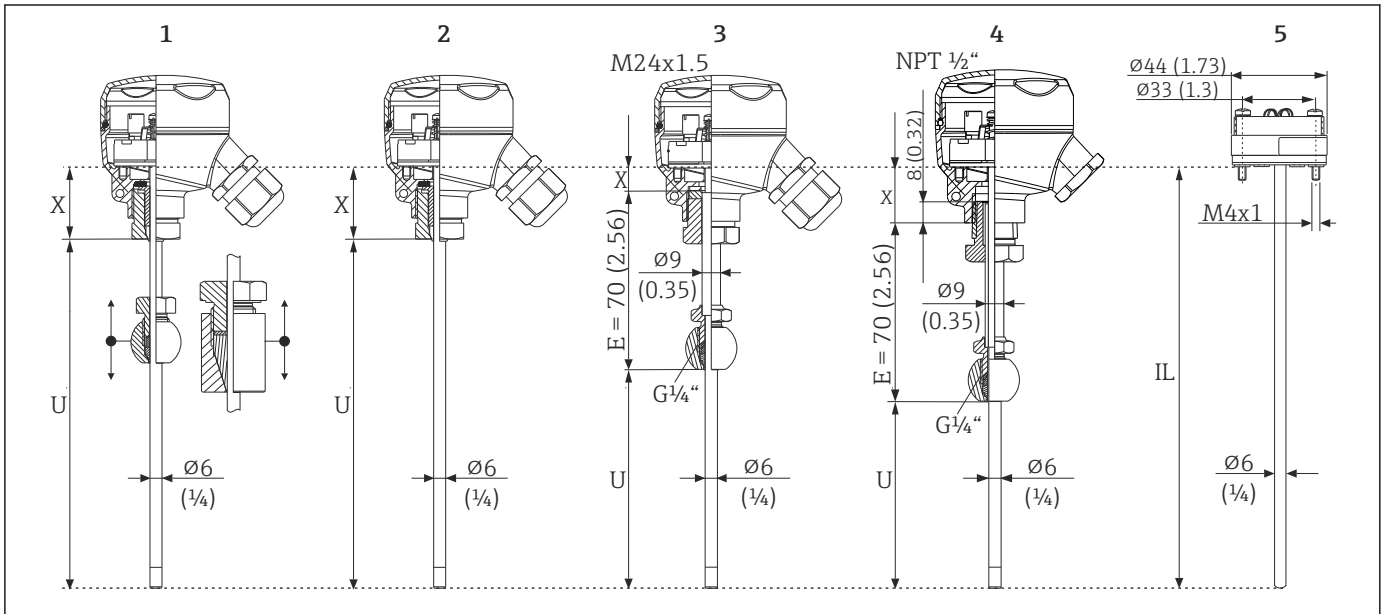

- 1 Movable compression fitting TK40 - variably fixable immersion length U, only connection thread M24x1.5
- 2 Without compression fitting for use if compression fitting is available at point of installation, insert with polished surface - product structure: feature 80, option A1 or A3 - only connection thread M24x1.5
- 3 Compression fitting TK40 fixed by extension neck - fixed immersion length U, connection thread M24x1.5
- 4 Compression fitting TK40 fixed by extension neck - fixed immersion length U, connection thread 1/2" NPT
- 5 Insert, for example with mounted head transmitter

Item	Version	Length
Extension neck length E	Extension neck $\varnothing 9$ mm (0.35 in)	70 mm (2.76 in)
Immersion length U	Independent of the version	Variable, depending on the configuration
Variable length X	<ul style="list-style-type: none"> <li>■ Versions 1 and 2: Without extension neck, connection thread M24x1.5</li> <li>■ Version 3: With extension neck, connection thread M24x1.5</li> <li>■ Version 4: With extension neck, connection thread 1/2" NPT</li> <li>■ With extension neck and TA30S terminal head</li> </ul>	<ul style="list-style-type: none"> <li>IL = U+X</li> <li>IL = U+E+X</li> <li>IL = U+E+X</li> <li>IL = U+E+X</li> </ul>
		<ul style="list-style-type: none"> <li>37 mm (1.46 in)</li> <li>11 mm (0.43 in)</li> <li>26 mm (1.02 in)</li> <li>31 mm (1.22 in)</li> </ul>

With thermowell diameter 6 mm (¼ in)

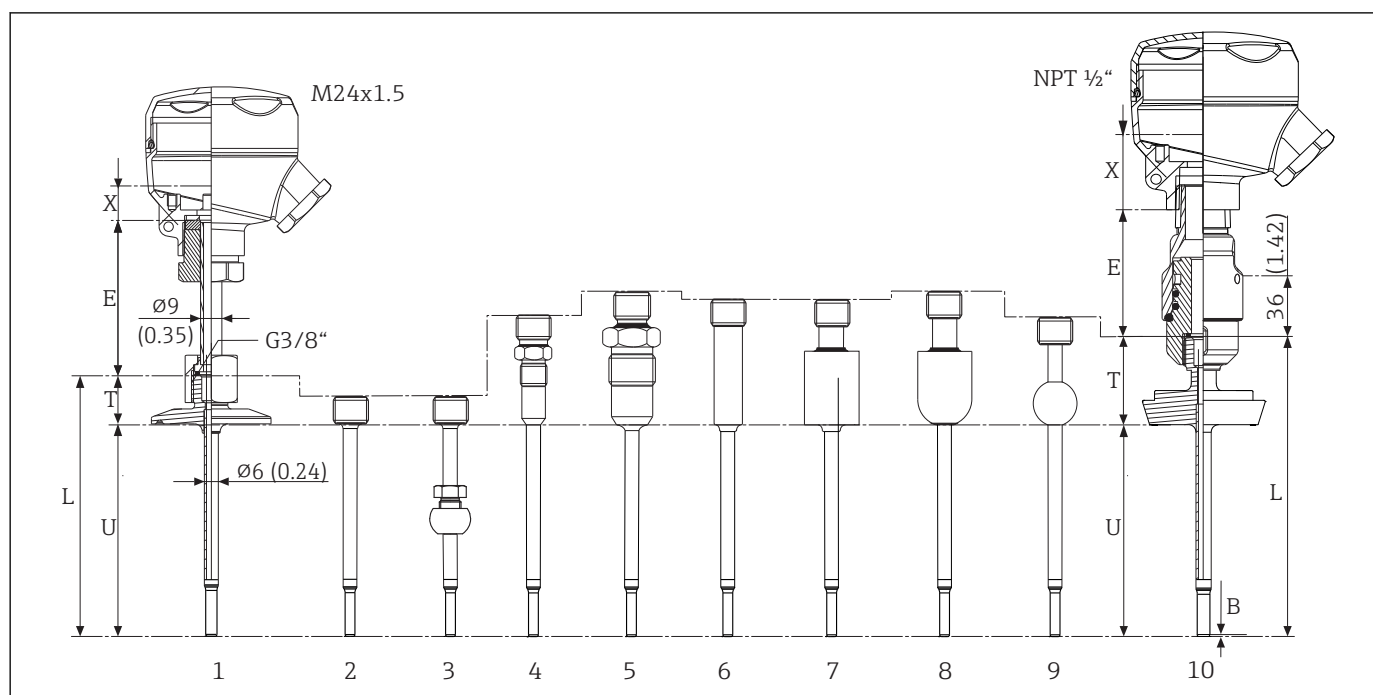

A0017790

- 1 Thermometer with replaceable extension neck TE411 and process connection as clamp version
- 2 Without process connection
- 3 Process connection version as spherical compression fitting TK40
- 4 Process connection version as metal sealing system M12x1.5
- 5 Process connection version as metal sealing system G½"
- 6 Process connection version as cylindrical weld-in adapter Ø12 x 40 mm
- 7 Process connection version as cylindrical weld-in adapter Ø30 x 40 mm
- 8 Process connection version as spherical-cylindrical weld-in adapter Ø30 x 40 mm
- 9 Process connection version as spherical weld-in adapter Ø25 mm
- 10 Thermometer with quick-fastening iTHERM QuickNeck and process connection as sanitary connection according to DIN 11851

- Replaceable extension neck or quick-fastening iTHERM QuickNeck
- Thread M24x1.5 or ½" NPT to terminal head
- G3/8" thread for thermowell connection

Item	Version	Length
Extension neck length E	Replaceable extension neck Ø9 mm (0.35 in)	Variable, depending on the configuration
	iTHERM QuickNeck with thread M24x1.5 to terminal head, with option: <ul style="list-style-type: none"> <li>■ A0: E not required</li> <li>■ X1: E= variable length</li> </ul>	<ul style="list-style-type: none"> <li>■ 60 mm (2.36 in)</li> <li>■ Variable, depending on the configuration</li> </ul>
	iTHERM QuickNeck with thread NPT ½" to terminal head, with option: <ul style="list-style-type: none"> <li>■ A0: E not required</li> <li>■ X1: E= variable length</li> </ul>	<ul style="list-style-type: none"> <li>■ 51 mm (2.00 in)</li> <li>■ Variable, depending on the configuration</li> </ul>
Length of thermowell lagging T <sup>1)</sup>	Metal sealing system M12x1.5	46 mm (1.81 in)
	Metal sealing system G½"	60 mm (2.36 in)
	Tri-clamp (0.5"-0.75")	24 mm (0.94 in)
	Microclamp (DN8-18)	23 mm (0.91 in)
	Clamp DN12 according to ISO 2852	24 mm (0.94 in)
	Clamp DN25/DN40 according to ISO 2852	21 mm (0.83 in)



Item	Version	Length
	Sanitary connection DN25/DN32/DN40 according to DIN 11851	29 mm (1.14 in)
	Spherical-cylindrical weld-in adapter	58 mm (2.28 in)
	Cylindrical weld-in adapter $\varnothing$ 12 mm (0.47 in)	55 mm (2.17 in)
	Without process connection (only G3/8" thread), where necessary with compression fitting TK40	11 mm (0.43 in)
	Cylindrical weld-in adapter	55 mm (2.17 in)
	Spherical weld-in adapter	47 mm (1.85 in)
Immersion length U	Independent of the version	Variable, depending on the configuration
Variable length X	<ul style="list-style-type: none"> <li>■ With connection thread M24x1.5</li> <li>■ With connection thread 1/2" NPT</li> <li>■ With terminal head TA30S</li> </ul> Calculation of IL for the insert: $IL = U + T + E - B + X$	14 mm (0.55 in) 29 mm (1.14 in) 34 mm (1.34 in)
Base thickness B	Reduced tip $\varnothing$ 4.3 mm (0.17 in)	3 mm (0.12 in)

1) Depends on the process connection

With thermowell diameter 9 mm (0.35 in)

Extension neck not replaceable, but can be separated with the option of the quick-fastening iTHERM QuickNeck.

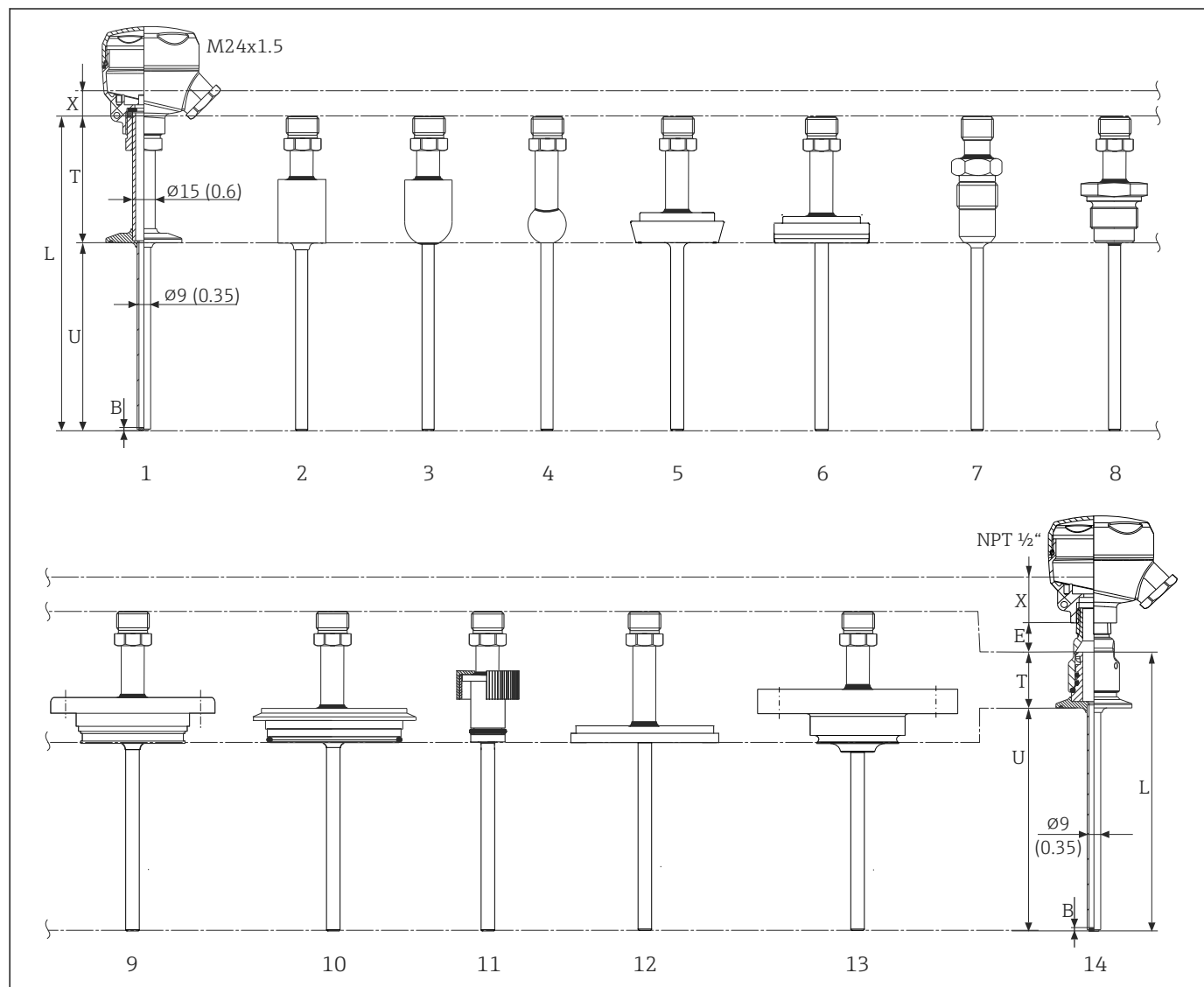

A0017761

- 1 Thermometer without replaceable extension neck, connection thread M24x1.5, process connection as clamp version
- 2 Process connection version as cylindrical weld-in adapter  $\varnothing 30 \times 40$  mm
- 3 Process connection version as spherical-cylindrical weld-in adapter  $\varnothing 30 \times 40$  mm
- 4 Process connection version as spherical weld-in adapter  $\varnothing 25$  mm
- 5 Process connection version as sanitary connection according to DIN 11851
- 6 Process connection version as aseptic pipe union according to DIN 11864-1 Form A
- 7 Process connection version as metal sealing system G $\frac{1}{2}$ "
- 8 Process connection thread as per ISO 228 for Liquiphant weld-in adapter
- 9 Process connection version APV Inline
- 10 Process connection version Varivent<sup>®</sup>
- 11 Process connection version Ingold connection
- 12 Process connection to SMS 1147
- 13 Process connection version Neumo Biocontrol
- 14 Thermometer with quick-fastening iTHERM QuickNeck and process connection, as clamp version for example

Item	Version	Length
Extension neck length E	Without iTHERM QuickNeck	0
	With iTHERM QuickNeck With thread M24x1.5 to terminal head <ul style="list-style-type: none"> <li>▪ A0: E not required</li> <li>▪ X1: E= variable length</li> </ul>	<ul style="list-style-type: none"> <li>▪ 28 mm (1.1 in)</li> <li>▪ Variable, depending on the configuration</li> </ul>

Item	Version	Length
	With thread ½" NPT to terminal head <ul style="list-style-type: none"> <li>■ A0: E not required</li> <li>■ X1: E= variable length</li> </ul>	<ul style="list-style-type: none"> <li>■ 19.5 mm (0.8 in)</li> <li>■ Variable, depending on the configuration</li> </ul>
Length of thermowell shaft T	Without iTHERM QuickNeck	Variable, depending on the configuration
	With iTHERM QuickNeck, depending on the process connection:	
	SMS 1147, DN25	40 mm (1.57 in)
	SMS 1147, DN38	41 mm (1.61 in)
	SMS 1147, DN51	42 mm (1.65 in)
	Varivent®, type F, D = 50 mm (1.97 in) Varivent®, type N, D = 68 mm (2.67 in)	52 mm (2.05 in)
	Varivent®, type B, D = 31 mm (1.22 in)	56 mm (2.2 in)
	G1" thread according to ISO 228 for Liquiphant weld-in adapter	77 mm (3.03 in)
	Spherical-cylindrical weld-in adapter	70 mm (2.76 in)
	Cylindrical weld-in adapter	67 mm (2.64 in)
	Aseptic pipe union according to DIN11864-A, DN25	42 mm (1.65 in)
	Aseptic pipe union according to DIN11864-A, DN40	43 mm (1.69 in)
	Sanitary connection according to DIN 11851, DN32	47 mm (1.85 in)
	Sanitary connection according to DIN 11851, DN40	
	Sanitary connection according to DIN 11851, DN50	
	Clamp according to ISO 2852, DN12	48 mm (1.89 in)
	Clamp according to ISO 2852, DN25	
	Clamp according to ISO 2852, DN40	
	Clamp according to ISO 2852, DN63.5	
	Clamp according to ISO 2852, DN70	39 mm (1.54 in)
	Microclamp (DN18)	
	Tri-clamp (0.75")	47 mm (1.85 in)
	Tri-clamp (0.75")	46 mm (1.81 in)
Ingold connection Ø25 mm (0.98 in) x 30 mm (1.18 in)	78 mm (3.07 in)	
Ingold connection Ø25 mm (0.98 in) x 46 mm (1.81 in)	94 mm (3.7 in)	
Metal sealing system G½"	74 mm (2.91 in)	
APV-Inline, DN50	51 mm (2.01 in)	
Immersion length U	Independent of the version	Variable, depending on the configuration
Variable length X	<ul style="list-style-type: none"> <li>■ Without iTHERM QuickNeck, connection thread M24x1.5</li> <li>■ With iTHERM QuickNeck, connection thread M24x1.5</li> <li>■ With iTHERM QuickNeck, connection thread NPT ½"</li> <li>■ With iTHERM QuickNeck, terminal head TA30S</li> </ul>	IL = U+T-B+X
		IL = U+E+T-B+X
		IL = U+E+T-B+X
		IL = U+E+T-B+X
Base thickness B	Reduced tip Ø5.3 mm (0.21 in) x 20 mm (0.79 in)	2 mm (0.08 in)
	Tapered tip Ø 6.6 mm (0.26 in) x 60 mm (2.36 in)	
	Straight tip	

With thermowell diameter 12.7 mm (½ in)

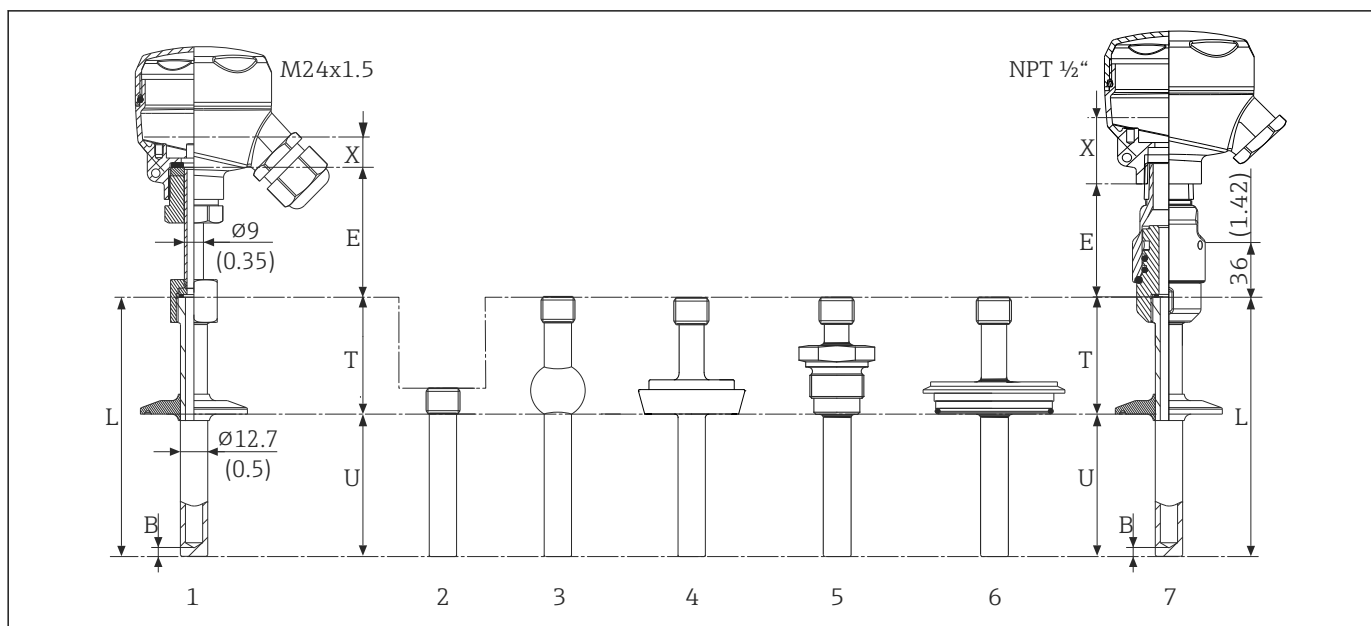

A0018313

- 1 Thermometer with replaceable extension neck TE411 and process connection as clamp version
- 2 Process connection version as cylindrical weld-in adapter  $\varnothing 12.7$  mm (0.5 in)
- 3 Process connection version as spherical weld-in adapter  $\varnothing 25$  mm
- 4 Process connection version as sanitary connection according to DIN 11851
- 5 Thread according to ISO 228 for Liquiphant weld-in adapter
- 6 Process connection version Varivent®
- 7 Thermometer with quick-fastening iTHERM QuickNeck and process connection, as clamp version for example

- Replaceable extension neck or quick-fastening iTHERM QuickNeck
- G3/8" thread for thermowell connection
- Thermowell welded at the tip

Item	Version	Length
Extension neck length E	Replaceable extension neck, $\varnothing 9$ mm (0.35 in)	Variable, depending on the configuration
	iTHERM QuickNeck with thread M24x1.5 to terminal head, with option: <ul style="list-style-type: none"> <li>■ A0: E not required</li> <li>■ X1: E= variable length</li> </ul>	<ul style="list-style-type: none"> <li>■ 60 mm (2.36 in)</li> <li>■ Variable, depending on the configuration</li> </ul>
	iTHERM QuickNeck with thread NPT ½" to terminal head, with option: <ul style="list-style-type: none"> <li>A0: E not required</li> </ul>	54 mm (2.13 in)
Length of thermowell shaft T	Weld-in adapter, cylindrical, $\varnothing 12.7$ mm (0.5 in) <sup>1)</sup>	12 mm (0.47 in)
	All other process connections	65 mm (2.56 in)
Immersion length U	Independent of the process connection	Variable, depending on the configuration
Variable length X	<ul style="list-style-type: none"> <li>■ With connection thread M24x1.5</li> <li>■ With connection thread ½" NPT</li> <li>■ With terminal head TA30S</li> </ul> Calculation of IL for the insert: $IL = U + T + E - B + X$	14 mm (0.55 in) 29 mm (1.14 in) 34 mm (1.34 in)
Base thickness B	Reduced tip $\varnothing 5.3$ mm (0.21 in) x 20 mm (0.79 in)	2 mm (0.079 in)

Item	Version	Length
	Reduced tip $\varnothing$ 8 mm (0.31 in) x 32 mm (1.26 in)	4 mm (0.16 in)
	Straight tip	6 mm (0.24 in)

1) See Fig. version 2

### Thermowell version as T-piece or elbow piece, optimized

No welds, no dead legs

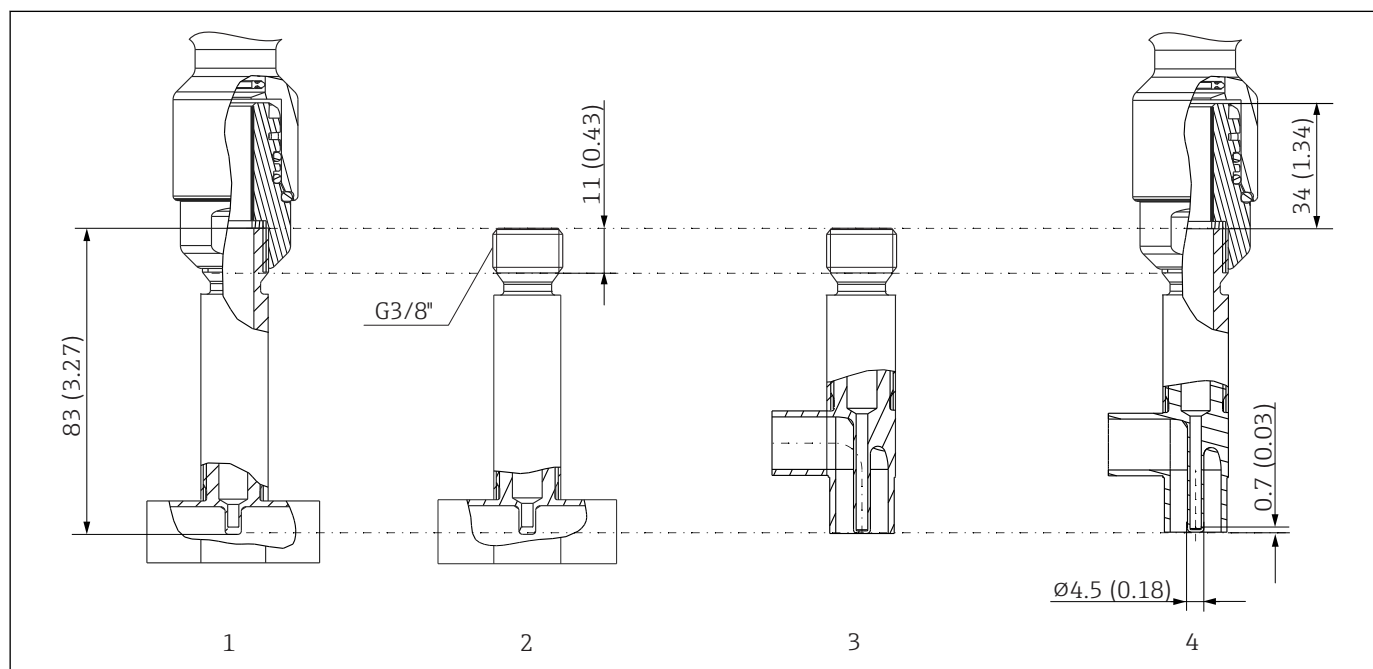

A0036509

#### 7 Thermowell as per DIN 11865 or ASME BPE

- 1 T-piece with threaded bottom part QuickNeck, torque 5 Nm (3.69 lbf ft), and glued with threadlocking adhesive
- 2 T-piece with extension neck connection G3/8"
- 3 Elbow piece with extension neck connection G3/8"
- 4 Elbow piece with threaded bottom part QuickNeck, torque 5 Nm (3.69 lbf ft), and glued with threadlocking adhesive

- Pipe sizes as per DIN 11865 series A (DIN), B (ISO) and C (ASME BPE) → 43
- 3-A<sup>®</sup> symbol for nominal diameters ≥ DN25
- EHEDG certification for nominal diameters ≥ DN25
- ASME BPE compliance for nominal diameters ≥ DN25
- IP69K protection class
- 1.4435+316L material, delta ferrite content < 0.5%
- Temperature range: -60 to +200 °C (-76 to +392 °F)
- Pressure range: PN25 as per DIN11865

**i** Due to the short immersion length U in the case of small pipe diameters, the use of iTHERM QuickSens inserts is recommended.

As a general rule, the longer the immersion length U the better the accuracy. For small pipe diameters it is advisable to use elbow pieces to enable a maximum immersion length U.

Suitable immersion lengths for the following thermometers:

- Easytemp TMR35: 83 mm (3.27 in)
- iTHERM TM411: 85 mm (3.35 in)
- iTHERM TM311: 85 mm (3.35 in)
- TrustSens TM371: 85 mm (3.35 in)

## Possible combinations of the thermowell versions with the available process connections and quick-fastening iTHERM QuickNeck

Process connection and size	Thermowell diameter			iTHERM QuickNeck for Ø9 mm (0.35 in) <sup>1)</sup>
	6 mm (¼ in)	9 mm (0.35 in)	12.7 mm (½ in)	
Without process connection (for installation with compression fitting)	☑	-	-	-
<b>Weld-in adapter</b>				
Cylindrical Ø12.7 mm (0.5 in)	-	-	☑	-
Cylindrical Ø30 x 40 mm	☑	☑	-	☑
Cylindrical Ø12 x 40 mm		-	-	-
Spherical-cylindrical Ø30 x 40 mm	☑	☑	-	☑
Spherical Ø25 mm (0.98 in)	☑	☑	☑	-
<b>Clamp according to ISO 2852</b>				
Microclamp/Tri-clamp DN18 (0.75 in)	☑ <sup>2)</sup>	☑	-	☑
DN12 - 21.3			☑	
DN25 -38 (1 - 1.5 in)	☑	☑	☑	☑
DN40 - 51 (2 in)			☑	
DN63.5 (2.5 in)	-	☑	☑	☑
DN70 - 76.5 (3 in)				
<b>Sanitary connection according to DIN 11851</b>				
DN25	☑	☑	☑	-
DN32, DN40				☑
DN50	-	-	-	☑
<b>Aseptic pipe union according to DIN 11864-1 Form A</b>				
DN25, DN40	-	☑	-	☑
<b>Metal sealing system</b>				
M12x1.5	☑	-	-	-
G½"		☑	-	☑
<b>Thread according to ISO 228 for Liquiphant weld-in adapter</b>				
G¾" for FTL20, FTL31, FTL33	-	☑	☑	-
G¾" for FTL50				-
G1" for FTL50				☑
<b>APV Inline</b>				
DN50	-	☑	-	☑
<b>Varivent®</b>				
Type B, Ø31 mm; Type F, Ø50 mm ; Type N, Ø68 mm	-	☑	☑	☑
<b>Ingold connection</b>				
25 x 30 mm or 25 x 46 mm	-	☑	-	☑
<b>SMS 1147</b>				
DN25, DN38, DN51	-	☑	-	☑
<b>Neumo Biocontrol</b>				
D25 PN16, D50 PN16, D65 PN16	-	☑	-	-

1) In the case of 6 mm (¼ in) and 12.7 mm (½ in) diameters, the iTHERM QuickNeck is available for all process connection versions.

2) Microclamp/Tri-clamp DN8 (0.5") only possible in combination with thermowell diameter = 6 mm (¼ in)

**Insert** Depending on the application, iTHERM TS111 inserts with different RTD sensors are available for the thermometer:

Sensor	Standard thin-film	iTHERM StrongSens	iTHERM QuickSens <sup>1)</sup>	Wire wound	
<b>Sensor design; connection method</b>	1x Pt100, 3- or 4-wire, mineral insulated	1x Pt100, 3- or 4-wire, mineral insulated	1x Pt100, 3- or 4-wire <ul style="list-style-type: none"> <li>▪ Ø6 mm (¼ in), mineral insulated</li> <li>▪ Ø3 mm (⅛ in), Teflon insulated</li> </ul>	1x Pt100, 3- or 4-wire, mineral insulated	2x Pt100, 3-wire, mineral insulated
<b>Vibration resistance of the insert tip</b>	Up to 3g	Enhanced vibration resistance > 60g	<ul style="list-style-type: none"> <li>▪ Ø3 mm (⅛ in) up to 3g</li> <li>▪ Ø6 mm (¼ in) &gt; 60g</li> </ul>	Up to 3g	
<b>Measuring range; accuracy class</b>	-50 to +400 °C (-58 to +752 °F), Class A or AA	-50 to +500 °C (-58 to +932 °F), Class A or AA	-50 to +200 °C (-58 to +392 °F), Class A or AA	-200 to +600 °C (-328 to +1 112 °F), Class A or AA	
<b>Diameter</b>	3 mm (⅛ in), 6 mm (¼ in)	6 mm (¼ in)	3 mm (⅛ in), 6 mm (¼ in)		

1) Recommended for immersion lengths  $U < 70$  mm (2.76 in)

The iTHERM TS111 insert is available as a spare part. The insertion length (IL) depends on the immersion length of the protection tube (U), the length of the extension neck (E), the thickness of the base (B), the length of the protection tube shaft (L) and the variable length (X). The insertion length (IL) must be taken into consideration when replacing the unit. Formulas for calculating IL →  20.

 For more information on the deployed iTHERM TS111 insert with enhanced vibration resistance and fast-response sensor, see the Technical Information (TI01014T/09/).

 Spare parts currently available for your product can be found online at: [http://www.products.endress.com/spareparts\\_consumables](http://www.products.endress.com/spareparts_consumables), product root: TM411. Always quote the serial number of the device when ordering spare parts! The insertion length IL is automatically calculated using the serial number.

**Weight** 0.5 to 2.5 kg (1 to 5.5 lbs) for standard options.

**Material** Extension neck and thermowell, insert, process connection.

The temperatures for continuous operation specified in the following table are only intended as reference values for use of the various materials in air and without any significant compressive load.



The maximum operating temperatures can be reduced considerably in cases where abnormal conditions such as high mechanical load occur or in aggressive media.

Designation	Short form	Recommended max. temperature for continuous use in air	Properties
AISI 316L (corresponds to 1.4404 or 1.4435)	X2CrNiMo17-13-2, X2CrNiMo18-14-3	650 °C (1202 °F) <sup>1)</sup>	<ul style="list-style-type: none"> <li>■ Austenitic, stainless steel</li> <li>■ High corrosion resistance in general</li> <li>■ Particularly high corrosion resistance in chlorine-based and acidic, non-oxidizing atmospheres through the addition of molybdenum (e.g. phosphoric and sulfuric acids, acetic and tartaric acids with a low concentration)</li> <li>■ Increased resistance to intergranular corrosion and pitting</li> <li>■ The wetted part in a protective tube is made of 316L or 1.4435+316L passivated with 3% sulfuric acid.</li> </ul>
1.4435+316L, delta ferrite < 1% or < 0.5%	With regard to analytical limits, the specifications of both materials (1.4435 and 316L) are met simultaneously. In addition, the delta ferrite content of the wetted parts is limited to <1% - including the welding seams (following Basel Standard II); or <0.5%		

1) Can be used to a limited extent up to 800 °C (1472 °F) for low compressive loads and in non-corrosive media. Contact your Endress+Hauser sales team for further information.

**Surface roughness**

Values for wetted surfaces:

Standard surface, mechanically polished <sup>1)</sup>	R <sub>a</sub> ≤ 0.76 µm (30 µin)
Mechanically polished <sup>1)</sup> , buffed <sup>2)</sup>	R <sub>a</sub> ≤ 0.38 µm (15 µin)
Mechanically polished <sup>1)</sup> , buffed and electropolished	R <sub>a</sub> ≤ 0.38 µm (15 µin) + electropolished

- 1) Or equivalent treatment that guarantees R<sub>a</sub> max
- 2) Not compliant with ASME BPE

**Terminal heads**

All terminal heads have an internal shape and size in accordance with DIN EN 50446, flat face and a thermometer connection with a M24x1.5 or ½" NPT thread. All dimensions in mm (in). The sample cable glands in the diagrams correspond to M20x1.5 connections with non-Ex polyamide cable glands. Specifications without head transmitter installed. For ambient temperatures with head transmitter installed, see the 'Environment' section. → 18

As a special feature, Endress+Hauser offers terminal heads with optimized terminal accessibility for easy installation and maintenance.

TA30A	Specification
	<ul style="list-style-type: none"> <li>■ Degree of protection: <ul style="list-style-type: none"> <li>■ IP66/68 (NEMA Type 4x incl.)</li> <li>■ For ATEX: IP66/67</li> </ul> </li> <li>■ Temperature: -50 to +150 °C (-58 to +302 °F) without cable gland</li> <li>■ Material: aluminum, polyester powder coated</li> <li>■ Seals: silicone</li> <li>■ Cable entry thread: G ½", ½" NPT and M20x1.5;</li> <li>■ Protective fitting connection: M24x1.5</li> <li>■ Color of head: blue, RAL 5012</li> <li>■ Color of cap: gray, RAL 7035</li> <li>■ Weight: 330 g (11.64 oz)</li> <li>■ Ground terminal, internal and external</li> <li>■ Available with sensors with 3-A® symbol</li> </ul>

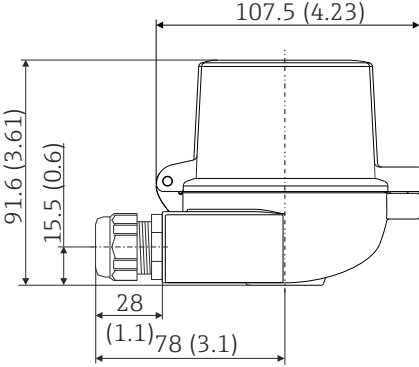
TA30A with display window in cover	Specification
 <p>A0009821</p>	<ul style="list-style-type: none"> <li>■ Degree of protection: <ul style="list-style-type: none"> <li>■ IP66/68 (NEMA Type 4x incl.)</li> <li>■ For ATEX: IP66/67</li> </ul> </li> <li>■ Temperature: -50 to +150 °C (-58 to +302 °F) without cable gland</li> <li>■ Material: aluminum, polyester powder coated</li> <li>Seals: silicone</li> <li>■ Cable entry thread: G ½", ½" NPT and M20x1.5</li> <li>■ Protective fitting connection: M24x1.5</li> <li>■ Color of head: blue, RAL 5012</li> <li>Color of cap: gray, RAL 7035</li> <li>■ Weight: 420 g (14.81 oz)</li> <li>■ With TID10 display</li> <li>■ Ground terminal, internal and external</li> <li>■ Available with sensors with 3-A® symbol</li> </ul>

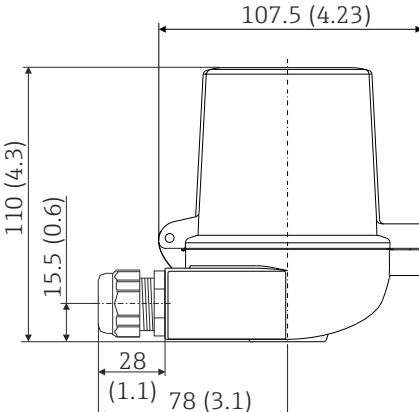
TA30D	Specification
 <p>A0009822</p>	<ul style="list-style-type: none"> <li>■ Degree of protection: <ul style="list-style-type: none"> <li>■ IP66/68 (NEMA Type 4x incl.)</li> <li>■ For ATEX: IP66/67</li> </ul> </li> <li>■ Temperature: -50 to +150 °C (-58 to +302 °F) without cable gland</li> <li>■ Material: aluminum, polyester powder coated</li> <li>Seals: silicone</li> <li>■ Cable entry thread: G ½", ½" NPT and M20x1.5</li> <li>■ Protective fitting connection: M24x1.5</li> <li>■ Two head transmitters can be mounted. In the standard configuration one transmitter is mounted in the terminal head cover and an additional terminal block is installed directly on the insert.</li> <li>■ Color of head: blue, RAL 5012</li> <li>■ Color of cap: gray, RAL 7035</li> <li>■ Weight: 390 g (13.75 oz)</li> <li>■ Ground terminal, internal and external</li> <li>■ Available with sensors with 3-A® symbol</li> </ul>

TA30P	Specification
	<ul style="list-style-type: none"> <li>■ Protection class: IP65</li> <li>■ Max. temperature: -40 to +120 °C (-40 to +248 °F)</li> <li>■ Material: polyamide (PA), antistatic</li> <li>■ Seals: silicone</li> <li>■ Threaded cable entry: M20x1.5</li> <li>■ Protection armature connection: M24x1.5</li> <li>■ Two head transmitters can be mounted. In the standard version, one transmitter is mounted in the terminal head cover and an additional terminal block is installed directly on the insert.</li> <li>■ Head and cap color: black</li> <li>■ Weight: 135 g (4.8 oz)</li> <li>■ Types of protection for use in hazardous locations: Intrinsic Safety (G Ex ia)</li> <li>■ Ground terminal: only internal via auxiliary clamp</li> <li>■ With 3-A<sup>®</sup> symbol</li> </ul>

TA30R (optionally with display window in cover)	Specification
<p data-bbox="507 1821 922 1872">* Dimensions of version with display window in cover</p>	<ul style="list-style-type: none"> <li>■ Degree of protection - standard version: IP69K (NEMA Type 4x incl.)</li> <li>■ Degree of protection - version with display window: IP66/68 (NEMA Type 4x incl.)</li> <li>■ Temperature: -50 to +130 °C (-58 to +266 °F) without cable gland</li> <li>■ Material: stainless steel 316L, abrasive-blasted or polished</li> <li>■ Seals: silicone, optional EPDM for applications free from paint-wetting impairment substances</li> <li>■ Display window: polycarbonate (PC)</li> <li>■ Cable entry thread ½" NPT and M20x1.5</li> <li>■ Weight <ul style="list-style-type: none"> <li>■ Standard version: 360 g (12.7 oz)</li> <li>■ Version with display window: 460 g (16.23 oz)</li> </ul> </li> <li>■ Display window in cover optionally for head transmitter with display TID10</li> <li>■ Protection armature connection: M24x1.5 or ½" NPT</li> <li>■ Ground terminal: internal in standard version; external terminal optionally available</li> <li>■ With 3-A<sup>®</sup> symbol</li> </ul>

TA30R (high version for two transmitters)	Specification
<p style="text-align: right; font-size: small;">A0034644</p>	<ul style="list-style-type: none"> <li>▪ Degree of protection: IP69K (NEMA Type 4x encl.)</li> <li>▪ Temperature: -50 to +130 °C (-58 to +266 °F) without cable gland</li> <li>▪ Material: stainless steel 316L, abrasive-blasted or polished</li> <li>▪ Seals: EPDM</li> <li>▪ Cable entry thread ½" NPT and M20x1.5</li> <li>▪ Weight: 460 g (16.23 oz)</li> <li>▪ For two head transmitter</li> <li>▪ Protection armature connection: M24x1.5 or ½" NPT</li> <li>▪ Ground terminal: internal in standard version; external terminal optionally available</li> <li>▪ With 3-A<sup>®</sup> symbol</li> </ul>

TA30S	Specification
<p style="text-align: right; font-size: small;">A0017146</p>	<ul style="list-style-type: none"> <li>▪ Degree of protection: IP65 (NEMA Type 4x encl.)</li> <li>▪ Temperature: -40 to +85 °C (-40 to +185 °F) without cable gland</li> <li>▪ Material: polypropylene (PP), FDA-compliant, seals: O-ring EPDM</li> <li>▪ Cable entry thread: ¾" NPT (with adapter for ½" NPT), M20x1.5</li> <li>▪ Protective assembly connection: ½" NPT</li> <li>▪ Color: white</li> <li>▪ Weight: approx. 100 g (3.5 oz)</li> <li>▪ Ground terminal: only internal via auxiliary terminal</li> <li>▪ Available in conjunction with 3-A marked sensors</li> </ul>

### Cable glands and fieldbus connectors

Type	Suitable for cable entry	Degree of protection	Temperature range
Cable gland, polyamide	½" NPT, ¾" NPT, M20x1.5 (optionally 2x cable entry)	IP68	-40 to +100 °C (-40 to +212 °F)
	½" NPT, M20x1.5 (optionally 2x cable entry)	IP69K	-20 to +95 °C (-4 to +203 °F)
Cable gland for dust ignition-proof area, polyamide	½" NPT, M20x1.5	IP68	-20 to +95 °C (-4 to +203 °F)
Cable gland for dust ignition-proof area, brass	M20x1.5	IP68 (NEMA Type 4x)	-20 to +130 °C (-4 to +266 °F)
Fieldbus connector (M12x1 PA, 7/8" PA, FF)	½" NPT, M20x1.5	IP67, NEMA Type 6	-40 to +105 °C (-40 to +221 °F)
Fieldbus connector (M12, 8-pin)	M20x1.5	IP67	-30 to +90 °C (-22 to +194 °F)

**Extension neck**

Standard version of extension neck, or optionally with quick-fastening iTHERM QuickNeck.

- Tool-free removal of the insert:
  - Saves time/costs on frequently calibrated measuring points
  - Wiring mistakes avoided
- IP69K protection class

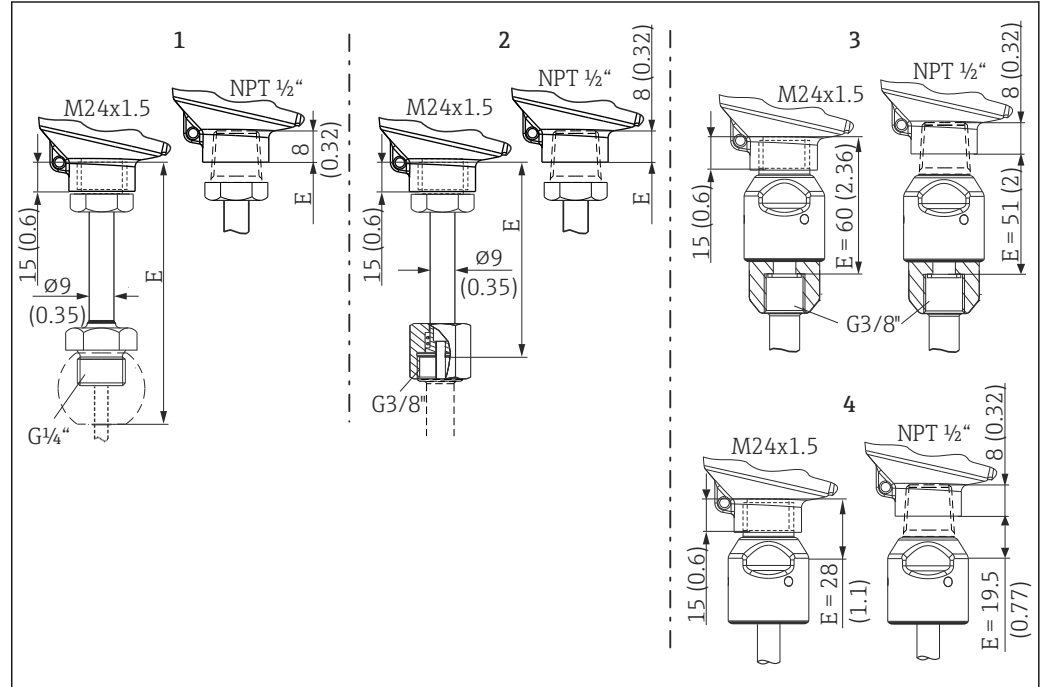

A0017953

8 Dimensions of extension neck type TE411, different versions, each with M24x1.5 or NPT 1/2" thread to the terminal head

- 1 With G1/4" external thread for compression fitting TK40, with → 463-A® symbol
- 2 With G3/8" thread adapter nut for thermowell version: Ø6 mm (1/4 in), Ø12.7 mm (0.5 in) and T-piece and elbow piece thermowell versions
- 3 Quick-fastening iTHERM QuickNeck for thermowell version: Ø6 mm (1/4 in), Ø12.7 mm (0.5 in) and T-piece and elbow piece thermowell versions
- 4 Quick-fastening iTHERM QuickNeck - top part, for installation in an existing protective tube with iTHERM QuickNeck

## Thermowell

## Process connections

All dimensions in mm (in).

Type	Version	Dimensions					Technical properties
		$\phi d$	$\phi D$	$\phi i$	$\phi a$	h	
Aseptic pipe union according to DIN 11864-1, Form A	DN25	26 mm (1.02 in)	42.9 mm (1.7 in)	26 mm (1.02 in)	29 mm (1.14 in)	9 mm (0.35 in)	<ul style="list-style-type: none"> <li>■ <math>P_{max.} = 40</math> bar (580 psi)</li> <li>■ With 3-A® symbol and EHEDG certification</li> <li>■ ASME BPE compliance</li> </ul>
	DN40	38 mm (1.5 in)	54.9 mm (2.16 in)	38 mm (1.5 in)	41 mm (1.61 in)	10 mm (0.39 in)	

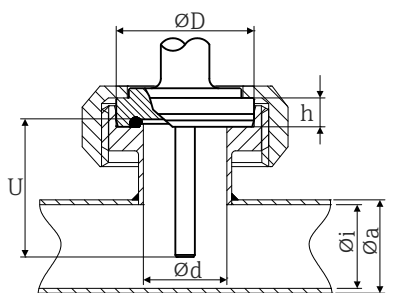

A0009562

## For welding in

Type	Version	Dimensions	Technical properties
Weld-in adapter 	1: Cylindrical <sup>1)</sup>	$\phi d = 12.7$ mm ( $\frac{1}{2}$ in), U = immersion length from lower edge of thread, T = 12 mm (0.47 in)	<ul style="list-style-type: none"> <li>■ <math>P_{max.}</math> depends on the weld-in process</li> <li>■ With 3-A® symbol and EHEDG certification</li> <li>■ ASME BPE compliance</li> </ul>
	2: Cylindrical <sup>2)</sup>	$\phi d \times h = 12$ mm (0.47 in) x 40 mm (1.57 in), T = 55 mm (2.17 in)	
	3: Cylindrical	$\phi d \times h = 30$ mm (1.18 in) x 40 mm (1.57 in)	
	4: Spherical-cylindrical	$\phi d \times h = 30$ mm (1.18 in) x 40 mm (1.57 in)	
	5: Spherical	$\phi d = 25$ mm (0.98 in) h = 24 mm (0.94 in)	

1) For thermowell  $\phi 12.7$  mm ( $\frac{1}{2}$  in)2) For thermowell  $\phi 6$  mm ( $\frac{1}{4}$  in)

Releasable process connection

Type						Technical properties
Sanitary connection according to DIN 11851						<ul style="list-style-type: none"> <li>With 3-A® symbol and EHEDG certification (only with EHEDG-certified and self-centering sealing ring).</li> <li>ASME BPE compliance</li> </ul>
<p>1 Centering ring 2 Sealing ring</p>						
Version <sup>1)</sup>	Dimensions					P <sub>max.</sub>
	øD	A	B	øi	øa	
DN25	44 mm (1.73 in)	30 mm (1.18 in)	10 mm (0.39 in)	26 mm (1.02 in)	29 mm (1.14 in)	40 bar (580 psi)
DN32	50 mm (1.97 in)	36 mm (1.42 in)	10 mm (0.39 in)	32 mm (1.26 in)	35 mm (1.38 in)	40 bar (580 psi)
DN40	56 mm (2.2 in)	42 mm (1.65 in)	10 mm (0.39 in)	38 mm (1.5 in)	41 mm (1.61 in)	40 bar (580 psi)
DN50	68 mm (2.68 in)	54 mm (2.13 in)	11 mm (0.43 in)	50 mm (1.97 in)	53 mm (2.1 in)	25 bar (363 psi)

1) Pipes in accordance with DIN 11850

Type	Version	Dimensions					Technical properties
		ø	øD	øi	øa	h	
Aseptic pipe union according to DIN 11864-1, Form A	DN25	26 mm (1.02 in)	42.9 mm (1.7 in)	26 mm (1.02 in)	29 mm (1.14 in)	9 mm (0.35 in)	<ul style="list-style-type: none"> <li>P<sub>max.</sub> = 40 bar (580 psi)</li> <li>With 3-A® symbol and EHEDG-tested</li> <li>ASME BPE compliance</li> </ul>
	DN40	38 mm (1.5 in)	54.9 mm (2.16 in)	38 mm (1.5 in)	41 mm (1.61 in)	10 mm (0.39 in)	

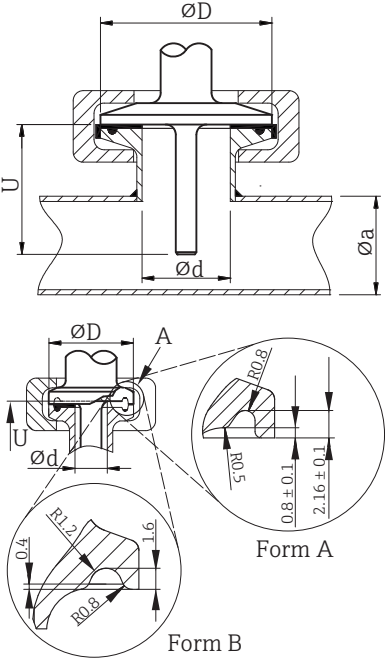
Type	Version	Dimensions		Technical properties	Conformity
	$\phi d$ : <sup>1)</sup>	$\phi D$	$\phi a$		
Clamp according to ISO 2852  <p>Form A: In compliance with ASME BPE Type A</p> <p>Form B: In compliance with ASME BPE Type B and ISO 2852</p> <p>A0009566</p>	Microclamp <sup>2)</sup> DN8-18 (0.5"-0.75") <sup>3)</sup> , Form A	25 mm (0.98 in)	-	<ul style="list-style-type: none"> <li>■ <math>P_{max.} = 16</math> bar (232 psi), depends on clamp ring and suitable seal</li> <li>■ With 3-A<sup>®</sup> symbol</li> </ul>	ASME BPE Type A
	Tri-clamp DN8-18 (0.5"-0.75") <sup>3)</sup> , Form B		-		Following ISO 2852 <sup>4)</sup>
	Clamp DN12-21.3, Form B	34 mm (1.34 in)	16 to 25.3 mm (0.63 to 0.99 in)		ISO 2852
	Clamp DN25-38 (1"-1.5"), Form B	50.5 mm (1.99 in)	29 to 42.4 mm (1.14 to 1.67 in)	<ul style="list-style-type: none"> <li>■ <math>P_{max.} = 16</math> bar (232 psi), depends on clamp ring and suitable seal</li> <li>■ With 3-A<sup>®</sup> symbol and EHEDG certification (in conjunction with Combifit seal)</li> </ul>	ASME BPE Type B; ISO 2852
	Clamp DN40-51 (2"), Form B	64 mm (2.52 in)	44.8 to 55.8 mm (1.76 to 2.2 in)	<ul style="list-style-type: none"> <li>■ Can be used with "Novaseptic Connect (NA Connect)" which enables flush-mount installation</li> </ul>	ASME BPE Type B; ISO 2852
	Clamp DN63,5 (2.5"), Form B	77.5 mm (3.05 in)	68.9 to 75.8 mm (2.71 to 2.98 in)		ASME BPE Type B; ISO 2852
	Clamp DN70-76.5 (3"), Form B	91 mm (3.58 in)	> 75.8 mm (2.98 in)		ASME BPE Type B; ISO 2852

- 1) Pipes in accordance with ISO 2037 and BS 4825 Part 1
- 2) Microclamp (not in ISO 2852); no standard pipes
- 3) DN8 (0.5") only possible with thermowell diameter = 6 mm (1/4 in)
- 4) Groove diameter = 20 mm



Type	Version	Technical properties
Metal sealing system		
<p><b>M12x1.5</b></p>	<p><b>G½"</b></p>	<p>Thermowell diameter 6 mm (¼ in)</p> <p><math>P_{max.} = 16 \text{ bar (232 psi)}</math></p> <p> Maximum torque = 10 Nm (7.38 lbf ft)</p>

Type	Version	Technical properties
<p>Process adapter</p>	D45	-

Type	Version G	Dimensions			Technical properties
		L1 thread length	A	1 (SW/AF)	
<p>Thread according to ISO 228 (for Liquiphant weld-in adapter)</p>	G¾" for FTL20/31/33 adapter	16 mm (0.63 in)	25.5 mm (1 in)	32	<ul style="list-style-type: none"> <li><math>P_{max.} = 25 \text{ bar (362 psi)}</math> at max. 150 °C (302 °F)</li> <li><math>P_{max.} = 40 \text{ bar (580 psi)}</math> at max. 100 °C (212 °F)</li> <li>With 3-A® symbol and EHEDG certification in conjunction with FTL31/33/50 adapter</li> <li>ASME BPE compliance</li> </ul>
	G¾" for FTL50 adapter				
	G1" for FTL50 adapter	18.6 mm (0.73 in)	29.5 mm (1.16 in)	41	

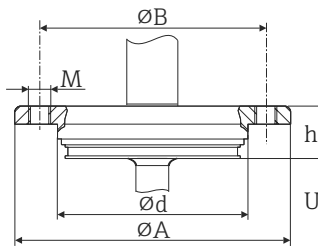
Type	Version	Dimensions					Technical properties
		$\phi d$	$\phi A$	$\phi B$	M	h	
APV Inline 	DN50	69 mm (2.72 in)	99.5 mm (3.92 in)	82 mm (3.23 in)	2xM8	19 mm (0.75 in)	<ul style="list-style-type: none"> <li>■ <math>P_{max.} = 25</math> bar (362 psi)</li> <li>■ With 3-A<sup>®</sup> symbol and EHEDG certification</li> <li>■ ASME BPE compliance</li> </ul>

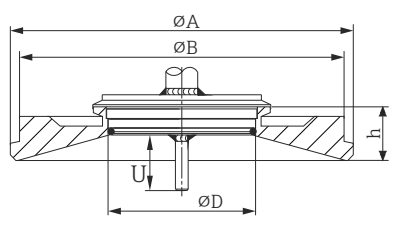
Type	Version	Dimensions				Technical properties	
		$\phi D$	$\phi A$	$\phi B$	h	$P_{max.}$	
Varivent <sup>®</sup> 	Type B	31 mm (1.22 in)	105 mm (4.13 in)	-	22 mm (0.87 in)	10 bar (145 psi)	<ul style="list-style-type: none"> <li>■ With 3-A<sup>®</sup> symbol and EHEDG certification</li> <li>■ ASME BPE compliance</li> </ul>
	Type F	50 mm (1.97 in)	145 mm (5.71 in)	135 mm (5.31 in)	24 mm (0.95 in)		
	Type N	68 mm (2.67 in)	165 mm (6.5 in)	155 mm (6.1 in)	24.5 mm (0.96 in)		

**i** The VARINLINE<sup>®</sup> housing connection flange is suitable for weld-in into the conical or torispherical head in tanks or vessels with a small diameter ( $\leq 1.6$  m (5.25 ft)) and up to a wall thickness of 8 mm (0.31 in).

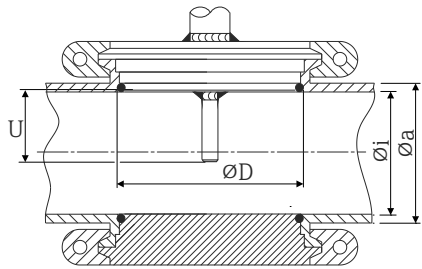
Type	Technical properties
Varivent <sup>®</sup> for VARINLINE <sup>®</sup> housing for installation in pipes 	<ul style="list-style-type: none"> <li>■ With 3-A<sup>®</sup> symbol and EHEDG certification</li> <li>■ ASME BPE compliance</li> </ul>

Version	Dimensions			$P_{max.}$
	$\phi D$	$\phi i$	$\phi a$	
Type N, according to DIN 11866, series A	68 mm (2.67 in)	DN40: 38 mm (1.5 in)	DN40: 41 mm (1.61 in)	DN40 to DN65: 16 bar (232 psi)
		DN50: 50 mm (1.97 in)	DN50: 53 mm (2.1 in)	
		DN65: 66 mm (2.6 in)	DN65: 70 mm (2.76 in)	
		DN80: 81 mm (3.2 in)	DN80: 85 mm (3.35 in)	DN80 to DN150: 10 bar (145 psi)
		DN100: 100 mm (3.94 in)	DN100: 104 mm (4.1 in)	
		DN125: 125 mm (4.92 in)	DN125: 129 mm (5.08 in)	
Type N, according to EN ISO 1127, series B	68 mm (2.67 in)	38.4 mm (1.51 in)	42.4 mm (1.67 in)	42.4 mm (1.67 in) to 60.3 mm (2.37 in): 16 bar (232 psi)
		44.3 mm (1.75 in)	48.3 mm (1.9 in)	

Type			Technical properties	
		56.3 mm (2.22 in)	60.3 mm (2.37 in)	76.1 mm (3 in) to 114.3 mm (4.5 in): 10 bar (145 psi)
		72.1 mm (2.84 in)	76.1 mm (3 in)	
		82.9 mm (3.26 in)	42.4 mm (3.5 in)	
		108.3 mm (4.26 in)	114.3 mm (4.5 in)	
Type N, according to DIN 11866, series C	68 mm (2.67 in)	OD 1½": 34.9 mm (1.37 in)	OD 1½": 38.1 mm (1.5 in)	OD 1½" to OD 2½": 16 bar (232 psi)
		OD 2": 47.2 mm (1.86 in)	OD 2": 50.8 mm (2 in)	
		OD 2½": 60.2 mm (2.37 in)	OD 2½": 63.5 mm (2.5 in)	
Type N, according to DIN 11866, series C	68 mm (2.67 in)	OD 3": 73 mm (2.87 in)	OD 3": 76.2 mm (3 in)	OD 3" to OD 4": 10 bar (145 psi)
		OD 4": 97.6 mm (3.84 in)	OD 4": 101.6 mm (4 in)	

 Due to the short immersion length U, the use of iTHERM QuickSens inserts is recommended.

T-piece, optimized (no welding, no dead legs)

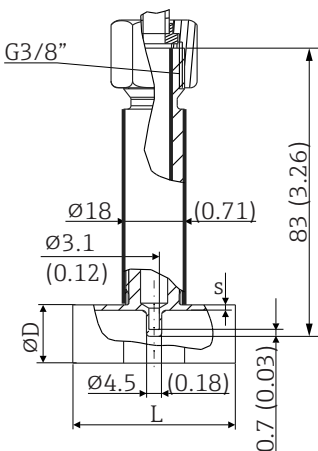
Type	Version		Dimensions in mm (in)			Technical properties
			ØD	L	s <sup>1)</sup>	
<p>T-piece for weld-in as per DIN 11865 (series A, B and C)</p>  <p>A0035898</p>	Series A	DN10 PN25	13 mm (0.51 in)	48 mm (1.89 in)	1.5 mm (0.06 in)	<ul style="list-style-type: none"> <li>■ P<sub>max.</sub> = 25 bar (362 psi)</li> <li>■ With 3-A® symbol and EHEDG certification for ≥ DN25</li> <li>■ ASME BPE compliance for ≥ DN25</li> </ul>
		DN15 PN25	19 mm (0.75 in)			
		DN20 PN25	23 mm (0.91 in)			
		DN25 PN25	29 mm (1.14 in)			
		DN32 PN25	32 mm (1.26 in)			
	Series B	DN13.5 PN25	13.5 mm (0.53 in)		1.6 mm (0.063 in)	
		DN17.2 PN25	17.2 mm (0.68 in)			
		DN21.3 PN25	21.3 mm (0.84 in)			
		DN26.9 PN25	26.9 mm (1.06 in)		2 mm (0.08 in)	
		DN33.7 PN25	33.7 mm (1.33 in)			
	Series C	DN12.7 PN25 (½")	12.7 mm (0.5 in)		1.65 mm (0.065 in)	
		DN19.05 PN25 (¾")	19.05 mm (0.75 in)			
		DN25.4 PN25 (1")	25.4 mm (1 in)			
		DN38.1 PN25 (1½")	38.1 mm (1.5 in)			

1) Wall thickness

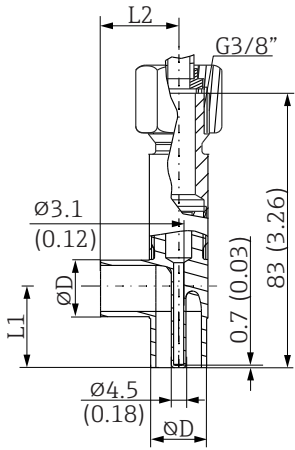

## Elbow piece, optimized (no welding, no dead legs)

Type	Version		Dimensions				Technical properties
			$\phi D$	L1	L2	s <sup>1)</sup>	
Elbow piece for weld-in as per DIN 11865 (series A, B and C)  <small>A0035899</small>	Series A	DN10 PN25	13 mm (0.51 in)	24 mm (0.95 in)	1.5 mm (0.06 in)	<ul style="list-style-type: none"> <li>■ P<sub>max.</sub> = 25 bar (362 psi)</li> <li>■ With 3-A<sup>®</sup> symbol and EHEDG certification for ≥ DN25</li> <li>■ ASME BPE compliance for ≥ DN25</li> </ul>	
		DN15 PN25	19 mm (0.75 in)	25 mm (0.98 in)			
		DN20 PN25	23 mm (0.91 in)	27 mm (1.06 in)			
		DN25 PN25	29 mm (1.14 in)	30 mm (1.18 in)			
		DN32 PN25	35 mm (1.38 in)	33 mm (1.3 in)			
	Series B	DN13.5 PN25	13.5 mm (0.53 in)	32 mm (1.26 in)	1.6 mm (0.063 in)		
		DN17.2 PN25	17.2 mm (0.68 in)	34 mm (1.34 in)			
		DN21.3 PN25	21.3 mm (0.84 in)	36 mm (1.41 in)			
		DN26.9 PN25	26.9 mm (1.06 in)	29 mm (1.14 in)			
		DN33.7 PN25	33.7 mm (1.33 in)	32 mm (1.26 in)	2.0 mm (0.08 in)		
	Series C	DN12.7 PN25 (½")	12.7 mm (0.5 in)	24 mm (0.95 in)	1.65 mm (0.065 in)		
		DN19.05 PN25 (¾")	19.05 mm (0.75 in)	25 mm (0.98 in)			
		DN25.4 PN25 (1")	25.4 mm (1 in)	28 mm (1.1 in)			
		DN38.1 PN25 (1½")	38.1 mm (1.5 in)	35 mm (1.38 in)			

1) Wall thickness

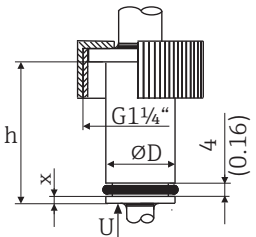
 Due to the short immersion length U, the use of iTHERM QuickSens inserts is generally recommended for T-piece/elbow piece process connections according to DIN 11865.

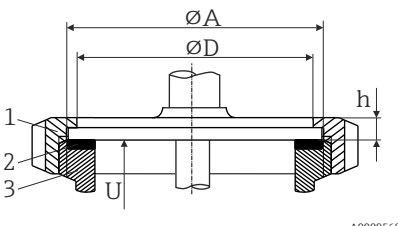
Type	Version, dimensions $\phi D \times h$	Technical properties
Ingold connection  <small>A0009573</small>	$\phi 25$ mm (0.98 in) x 30 mm (1.18 in) x = 1.5 mm (0.06 in)	P <sub>max.</sub> = 25 bar (362 psi) A seal is included in the scope of delivery. Material V75SR: compliance with FDA, 3-A <sup>®</sup> Sanitary Standard 18-03 Class 1 and USP Class VI
	$\phi 25$ mm (0.98 in) x 46 mm (1.81 in) x = 6 mm (0.24 in)	

Type	Version	Dimensions			Technical properties
		$\phi D$	$\phi A$	h	
SMS 1147  1 Thread adapter nut 2 Sealing ring 3 Counterpart connection A0009568	DN25	32 mm (1.26 in)	35.5 mm (1.4 in)	7 mm (0.28 in)	$P_{max.} = 6 \text{ bar (87 psi)}$
	DN38	48 mm (1.89 in)	55 mm (2.17 in)	8 mm (0.31 in)	
	DN51	60 mm (2.36 in)	65 mm (2.56 in)	9 mm (0.35 in)	
 The counterpart connection must fit the sealing ring and fix it in place.					

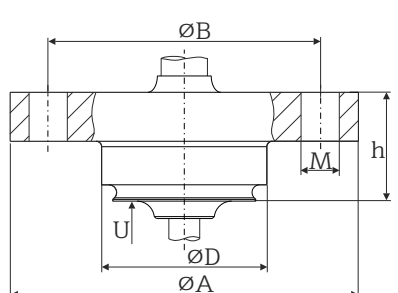
Type	Version	Dimensions					Technical properties
		$\phi A$	$\phi B$	$\phi D$	$\phi d$	h	
Neumo Biocontrol  A0018497	D25 PN16	64 mm (2.52 in)	50 mm (1.97 in)	30.4 mm (1.2 in)	7 mm (0.28 in)	20 mm (0.79 in)	<ul style="list-style-type: none"> <li>■ <math>P_{max.} = 16 \text{ bar (232 psi)}</math></li> <li>■ With 3-A® symbol</li> </ul>
	D50 PN16	90 mm (3.54 in)	70 mm (2.76 in)	49.9 mm (1.97 in)	9 mm (0.35 in)	27 mm (1.06 in)	
	D65 PN25	120 mm (4.72 in)	95 mm (3.74 in)	67.9 mm (2.67 in)	11 mm (0.43 in)		

## Compression fitting

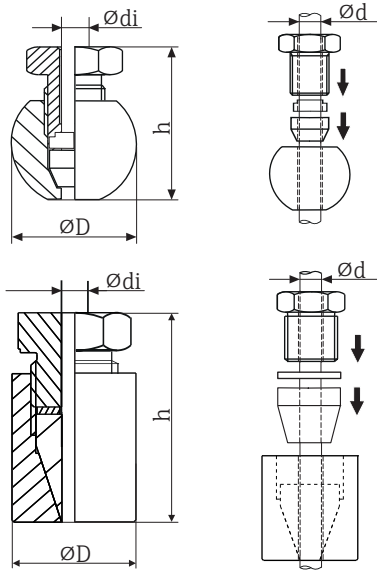
Type	Version	Dimensions			Technical properties <sup>1)</sup>
	Spherical or cylindrical	$\phi di$	$\phi D$	h	
Compression fitting TK40 for weld-in 	Spherical Ferrule material PEEK or 316L Thread G $\frac{1}{4}$ "	6.3 mm (0.25 in) <sup>2)</sup>	25 mm (0.98 in)	33 mm (1.3 in)	<ul style="list-style-type: none"> <li>■ P<sub>max.</sub> = 10 bar (145 psi), T<sub>max.</sub> = +150 °C (+302 °F) for PEEK material, tightening torque = 10 Nm</li> <li>■ P<sub>max.</sub> = 50 bar (725 psi), T<sub>max.</sub> = +200 °C (+392 °F) for 316L material, tightening torque = 25 Nm</li> <li>■ PEEK ferrule has 3-A<sup>®</sup> symbol and is EHEDG-tested.</li> </ul>
	Cylindrical Ferrule material Wacker <sup>®</sup> ELASTOSIL thread G $\frac{1}{2}$ "	6.2 mm (0.24 in) <sup>2)</sup>	9.2 mm (0.36 in)	30 mm (1.18 in)	57 mm (2.24 in)

1) All the pressure specifications apply for cyclic temperature load

2) For insert or thermowell diameter  $\phi d = 6$  mm (0.236 in).

**i** The 316L compression fittings can only be used once due to deformation. This applies to all the components of the compression fittings! A replacement compression fitting must be fastened at another point (grooves in thermowell). PEEK compression fittings must never be used at a temperature that is lower than the temperature present when the compression fitting is secured. This is because the fitting would no longer be leak-tight as a result of heat contraction of the PEEK material.

If stricter requirements must be met, the use of SWAGELOCK or similar fasteners is urgently recommended.

### Tip shape

The thermal response time, the reduction of the flow cross-section and the mechanical load that occurs in the process are the criteria that matter when selecting the shape of the tip. Advantages of using reduced or tapered thermometer tips:

- A smaller tip shape has less impact on the flow characteristics of the pipe carrying the medium.
- The flow characteristics are optimized, thereby increasing the stability of the thermowell.
- Endress+Hauser offers users a range of thermowell tips to meet every requirement:
  - Reduced tip with  $\phi 4.3$  mm (0.17 in) and  $\phi 5.3$  mm (0.21 in): walls of lower thickness significantly reduce the response times of the overall measuring point.
  - Tapered tip with  $\phi 6.6$  mm (0.26 in) and reduced tip with  $\phi 8$  mm (0.31 in): walls of greater thickness are particularly well suited to applications with a higher degree of mechanical load or wear (e.g. pitting, abrasion etc.).

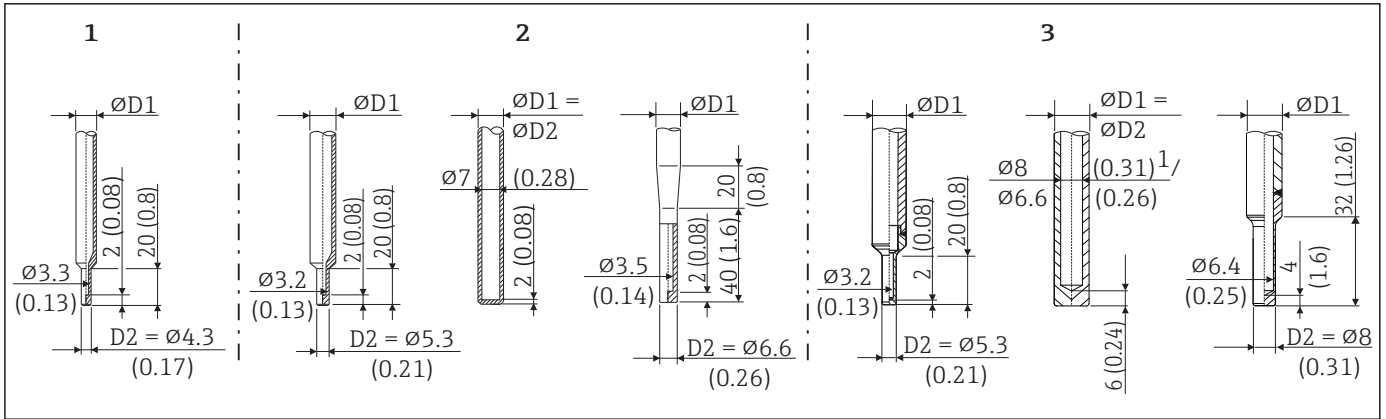



A0017174

9 Thermowell tips available (reduced, straight or tapered)

Item No.	Thermowell ( $\varnothing D1$ )	Insert ( $\varnothing ID$ )
1	$\varnothing 6$ mm ( $\frac{1}{4}$ in)	Reduced tip $\varnothing 3$ mm ( $\frac{1}{8}$ in)
2	$\varnothing 9$ mm (0.35 in)	<ul style="list-style-type: none"> <li>Reduced tip with <math>\varnothing 5.3</math> mm (0.21 in)</li> <li>Straight tip</li> <li>Tapered tip with <math>\varnothing 6.6</math> mm (0.26 in)</li> </ul> <ul style="list-style-type: none"> <li><math>\varnothing 3</math> mm (<math>\frac{1}{8}</math> in)</li> <li><math>\varnothing 6</math> mm (<math>\frac{1}{4}</math> in)</li> <li><math>\varnothing 3</math> mm (<math>\frac{1}{8}</math> in)</li> </ul>
3	$\varnothing 12.7$ mm ( $\frac{1}{2}$ in)	<ul style="list-style-type: none"> <li>Reduced tip with <math>\varnothing 5.3</math> mm (0.21 in)</li> <li>Straight tip</li> <li>Reduced tip with <math>\varnothing 8</math> mm (0.31 in)</li> </ul> <ul style="list-style-type: none"> <li><math>\varnothing 3</math> mm (<math>\frac{1}{8}</math> in)</li> <li><math>\varnothing 6</math> mm (<math>\frac{1}{4}</math> in)</li> <li><math>\varnothing 6</math> mm (<math>\frac{1}{4}</math> in)</li> </ul>

**i** It is possible to check the mechanical loading capacity as a function of the installation and process conditions online in the TW Sizing Module for thermowells in the Endress+Hauser Applicator software. See "Accessories" section. → 54

## Certificates and approvals

<b>CE mark</b>	The product meets the requirements of the harmonized European standards. As such, it complies with the legal specifications of the EU directives. The manufacturer confirms successful testing of the product by affixing to it the CE mark.
<b>Hygiene standard</b>	<ul style="list-style-type: none"> <li>■ EHEDG certification, type EL CLASS I. EHEDG-certified/tested process connections in accordance with EHEDG →  38</li> <li>■ 3-A® authorization no. 1144, 3-A® Sanitary Standard 74-07. Listed process connections →  38</li> <li>■ ASME BPE, declaration of conformity, can be ordered for options indicated</li> <li>■ FDA-compliant</li> <li>■ All surfaces in contact with the medium are free from materials derived from bovine animals or other livestock (ADI/ISE)</li> </ul>
<b>Ex approval</b>	Information about currently available Ex versions (ATEX, FM, CSA, etc.) can be supplied by your E+H Sales Center on request. All explosion protection data are given in separate documentation which is available upon request.
<b>Other standards and guidelines</b>	<ul style="list-style-type: none"> <li>■ IEC 60529: Degrees of protection provided by enclosures (IP code)</li> <li>■ IEC 61010-1: Safety requirements for electrical equipment for measurement, control and laboratory use</li> <li>■ IEC 60751: Industrial platinum resistance thermometers</li> <li>■ DIN 43772: Thermowells</li> <li>■ DIN EN 50446: Terminal heads</li> </ul>
<b>CRN approval</b>	<p>The CRN approval is only available for certain thermowell versions. These versions are identified and displayed accordingly during the configuration of the device.</p> <p>Detailed ordering information is available for your nearest sales organization <a href="http://www.addresses.endress.com">www.addresses.endress.com</a> or in the Download Area under <a href="http://www.endress.com">www.endress.com</a> :</p> <ol style="list-style-type: none"> <li>1. Select the country</li> <li>2. Select Downloads</li> <li>3. In the search area: select Approvals/approval type</li> <li>4. Enter the product code or device</li> <li>5. Start the search</li> </ol>
<b>Areas in contact with medium</b>	<p>The areas of the thermometer in contact with food/product (FCM) comply with the following European regulations:</p> <ul style="list-style-type: none"> <li>■ (EC) No. 1935/2004, Article 3, paragraph 1, Articles 5 and 17 on materials and articles intended to come into contact with food.</li> <li>■ (EC) No. 2023/2006 on good manufacturing practice for materials and articles intended to come into contact with food.</li> <li>■ (EC) No. 10/2011 on plastic materials and articles intended to come into contact with food.</li> <li>■ FDA-compliant</li> <li>■ All surfaces in contact with medium are produced without animal fats (ADI/TSE)</li> </ul>
<b>Surface roughness</b>	<ul style="list-style-type: none"> <li>■ Free from oil and grease for O<sub>2</sub> applications, optional</li> <li>■ PWIS-free (PWIS = paint-wetting impairment substances as per DIL0301), optional</li> </ul>
<b>Material resistance</b>	Material resistance (including housing) to the following cleaning agents/disinfectants from the company Ecolab: P3-topax 66, P3-topactive 200, P3-topactive 500 and P3-topactive OKTO as well as demineralized water.
<b>Material certification</b>	The material certificate 3.1 (according to standard EN 10204) can be requested separately. The "short form" certificate includes a simplified declaration with no enclosures of documents related to the materials used in the construction of the single sensor and guarantees the traceability of the materials through the identification number of the thermometer. The data related to the origin of the materials can subsequently be requested by the client if necessary.



---

**Calibration**

The "Factory calibration" is carried out according to an internal procedure in a laboratory of Endress+Hauser accredited by the European Accreditation Organization (EA) to ISO/IEC 17025. A calibration which is performed according to EA guidelines (SIT/Accredia) or (DKD/DAkkS) may be requested separately. The calibration is performed on the replaceable insert of the thermometer. In the case of thermometers without a replaceable insert, the entire thermometer - from the process connection to the tip of the thermometer - is calibrated.

---

**Thermowell testing and load capacity calculation**

- Thermowell pressure tests are carried out in accordance with the specifications in DIN 43772. With regard to thermowells with tapered or reduced tips that do not comply with this standard, these are tested using the pressure of the corresponding straight thermowells. Tests according to other specifications can be carried out on request. The liquid penetration test verifies that there are no cracks in the welded seams of the thermowell.
- EN1779 helium leak test, PMI test, concentricity test for drilled thermowells, dye penetration test, TW welding, internal hydrostatic pressure, etc. each with inspection certificate
- Load capacity calculation for the thermowell as per DIN43772

## Ordering information

Detailed ordering information is available for your nearest sales organization [www.addresses.endress.com](http://www.addresses.endress.com) or in the Product Configurator under [www.endress.com](http://www.endress.com) :

1. Click Corporate
2. Select the country
3. Click Products
4. Select the product using the filters and search field
5. Open the product page

The Configuration button to the right of the product image opens the Product Configurator.

**Product Configurator - the tool for individual product configuration**

- Up-to-the-minute configuration data
- Depending on the device: Direct input of measuring point-specific information such as measuring range or operating language
- Automatic verification of exclusion criteria
- Automatic creation of the order code and its breakdown in PDF or Excel output format
- Ability to order directly in the Endress+Hauser Online Shop

## Accessories

Various accessories, which can be ordered with the device or subsequently from Endress+Hauser, are available for the device. Detailed information on the order code in question is available from your local Endress+Hauser sales center or on the product page of the Endress+Hauser website: [www.endress.com](http://www.endress.com).

## Device-specific accessories

Accessories	Description
<p>Welding boss with sealing taper (metal - metal)</p> <p>A0006621</p> <p>A0018236</p>	<p>Welding boss for G<math>\frac{1}{2}</math>"- and M12x1 thread Metal-sealing; conical Material of wetted parts: 316L/1.4435 Max. process pressure 16 bar (232 PSI)</p> <p><b>Order number:</b></p> <ul style="list-style-type: none"> <li>71424800 (G<math>\frac{1}{2}</math>" )</li> <li>71405560 (M12x1)</li> </ul>
<p>Dummy plug</p> <p>A0009213-EN</p>	<p>Dummy plug for G<math>\frac{1}{2}</math>" or M12x1 conical metal-sealing welding boss Material: SS 316L/1.4435</p> <p><b>Order number:</b></p> <ul style="list-style-type: none"> <li>60022519 (G<math>\frac{1}{2}</math>" )</li> <li>60021194 (M12x1)</li> </ul>

Accessories	Description
<p>Weld-in adapter for FTL31/33/20, pipe mounting</p> <p>A0008265</p>	<ul style="list-style-type: none"> <li>G<math>\frac{3}{4}</math>", d=29 mm, without flange</li> <li>Material: 316L</li> <li>Roughness in <math>\mu\text{m}</math> (<math>\mu\text{in}</math>), 1.5 (59.1)</li> <li>Order number 52028295 (with inspection certificate EN10204-3.1 material)</li> <li>Order number for seal (5-pc. set), silicone O-ring 52021717<sup>1)</sup>, FDA-compliant</li> </ul>

1) A seal is included in the delivery.

Accessories	Description
<p>Weld-in adapter for FTL31/33/20, vessel mounting</p> <p style="text-align: right; font-size: small;">A0008810</p>	<ul style="list-style-type: none"> <li>▪ G<math>\frac{3}{4}</math>"<math>\phi</math>, d=50 mm, with flange</li> <li>▪ Material 316L</li> <li>▪ Roughness in <math>\mu\text{m}</math> (<math>\mu\text{in}</math>), 0.8 (31.5)</li> <li>▪ Order number 52018765 (with inspection certificate EN10204-3.1 material)</li> <li>▪ Order number for seal (5-pc. set), silicone O-ring 52021717<sup>1)</sup>, FDA-compliant</li> <li>▪ EHEDG-tested and with 3-A mark</li> </ul>

1) A seal is included in the delivery.

Accessories	Description
<p>Weld-in adapter for FTL50</p> <p style="text-align: right; font-size: small;">A0008274</p>	<ul style="list-style-type: none"> <li>▪ G<math>\frac{3}{4}</math>"<math>\phi</math>, d=55 mm, with flange</li> <li>▪ Material 316L</li> <li>▪ Roughness in <math>\mu\text{m}</math> (<math>\mu\text{in}</math>), 0.8 (31.5)</li> <li>▪ Order number 52001052 (without inspection certificate EN10204-3.1 material)</li> <li>▪ Order number 52011897 (with inspection certificate EN10204-3.1 material)</li> <li>▪ Order number for seal (5-pc. set), silicone O-ring 52014473<sup>1)</sup>, FDA-compliant</li> <li>▪ EHEDG-tested and with 3-A mark</li> </ul>

1) A seal is included in the delivery.

Accessories	Description
<p>Weld-in adapter for FTL50</p> <p style="text-align: right; font-size: small;">A0011927</p>	<ul style="list-style-type: none"> <li>▪ G1"<math>\phi</math>, d=53 mm, without flange</li> <li>▪ Material 316L</li> <li>▪ Roughness in <math>\mu\text{m}</math> (<math>\mu\text{in}</math>), 0.8 (31.5)</li> <li>▪ Order number 71093129 (with inspection certificate EN10204-3.1 material)</li> <li>▪ Order number for seal (5-pc. set), silicone O-ring 52014472<sup>1)</sup>, FDA-compliant</li> </ul>

1) A seal is included in the delivery.

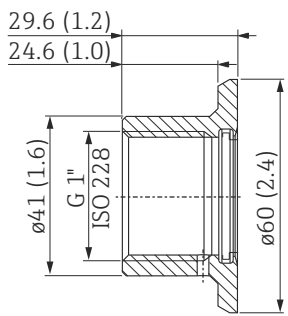
Accessories	Description
<p>Weld-in adapter for FTL50</p>  <p style="text-align: right;">A0008267</p>	<ul style="list-style-type: none"> <li>■ G1", d=60 mm, with flange</li> <li>■ Material 316L</li> <li>■ Roughness in <math>\mu\text{m}</math> (<math>\mu\text{in}</math>), 0.8 (31.5)</li> <li>■ <b>Order number:</b> 52001051 (without inspection certificate EN10204-3.1 material)</li> <li>■ Order number 52011896 (with inspection certificate EN10204-3.1 material)</li> <li>■ Order number seal (5-pc. set): silicone O-ring 52014472 <sup>1)</sup>, FDA-compliant</li> <li>■ EHEDG-tested and with 3-A mark</li> </ul>

1) A seal is included in the delivery.

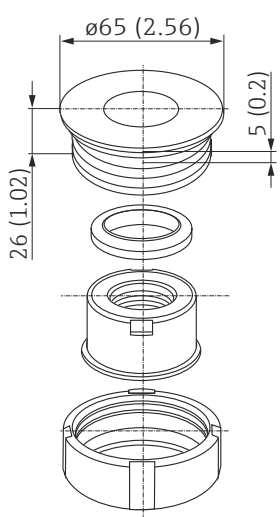
Accessories	Description
<p>Weld-in adapter for FTL50</p>  <p style="text-align: right;">A0008272</p>	<ul style="list-style-type: none"> <li>■ G1", can be aligned</li> <li>■ Material 316L</li> <li>■ Roughness in <math>\mu\text{m}</math> (<math>\mu\text{in}</math>), 0.8 (31.5)</li> <li>■ Order number 52001221 (without inspection certificate EN10204-3.1 material)</li> <li>■ Order number 52011898 (with inspection certificate EN10204-3.1 material)</li> <li>■ Order number for seal (5-pc. set), silicone O-ring 52014424 <sup>1)</sup>, FDA-compliant</li> </ul>

1) A seal is included in the delivery.

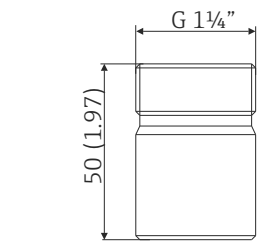

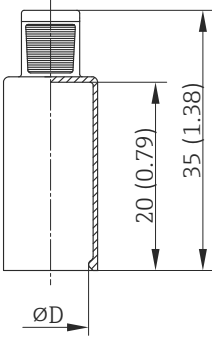



<p>Weld-in adapter for Ingold process connection (OD25 mm (0.98 in)x46 mm (1.81 in))</p>  <p style="text-align: right;">A0008956</p>	<p>Material of wetted parts: 316L/1.4435 Weight: 0.32 kg (0.7 lb) <b>Order number:</b> 60017887</p> <p>O-ring seal set</p> <ul style="list-style-type: none"> <li>■ Silicone O-ring in accordance with FDA CFR 21</li> <li>■ Maximum temperature: 230 °C (446 °F)</li> <li>■ <b>Order number:</b> 60018911</li> </ul>
---	---

<p>Flexible handle cap to cover the QuickNeck bottom part</p> 	<p>Diameter ØD: 24 to 26 mm (0.94 to 1.02 in)                  Material: Thermoplastic polyolefin - elastomer (TPE), free from plasticizers                  Maximum temperature: +150 °C (+302 °F)  <b>Order number: 71275424</b></p>
---	--

-  Maximum process pressure for the weld-in adapters:
  - 25 bar (362 PSI) at maximum 150 °C (302 °F)
  - 40 bar (580 PSI) at maximum 100 °C (212 °F)

 For more information on the weld-in adapters FTL20/31/33, FTL50, see the Technical Information (TI00426F/00).



**Communication-specific accessories**

Configuration kit TXU10	Configuration kit for PC-programmable transmitter with setup software and interface cable for PC with USB port Order code: TXU10-xx
Commubox FXA195 HART	For intrinsically safe HART communication with FieldCare via the USB interface.  For details, see "Technical Information" TI00404F
Commubox FXA291	Connects Endress+Hauser field devices with a CDI interface (= Endress+Hauser Common Data Interface) and the USB port of a computer or laptop.  For details, see "Technical Information" TI00405C
HART Loop Converter HMX50	Is used to evaluate and convert dynamic HART process variables to analog current signals or limit values.  For details, see "Technical Information" TI00429F and Operating Instructions BA00371F
Wireless HART adapter SWA70	Is used for the wireless connection of field devices. The WirelessHART adapter can be easily integrated into field devices and existing infrastructures, offers data protection and transmission safety and can be operated in parallel with other wireless networks with minimum cabling complexity.  For details, see Operating Instructions BA061S
Fieldgate FXA320	Gateway for the remote monitoring of connected 4-20 mA measuring devices via a Web browser.  For details, see "Technical Information" TI00025S and Operating Instructions BA00053S
Fieldgate FXA520	Gateway for the remote diagnostics and remote configuration of connected HART measuring devices via a Web browser.  For details, see "Technical Information" TI00025S and Operating Instructions BA00051S
Field Xpert SFX100	Compact, flexible and robust industry handheld terminal for remote configuration and for obtaining measured values via the HART current output (4-20 mA).  For details, see Operating Instructions BA00060S

## Service-specific accessories

Accessories	Description
Applicator	<p>Software for selecting and sizing Endress+Hauser measuring devices:</p> <ul style="list-style-type: none"> <li>■ Calculation of all the necessary data for identifying the optimum measuring device: e.g. pressure loss, accuracy or process connections.</li> <li>■ Graphic illustration of the calculation results</li> </ul> <p>Administration, documentation and access to all project-related data and parameters over the entire life cycle of a project.</p> <p>Applicator is available:</p> <ul style="list-style-type: none"> <li>■ Via the Internet: <a href="https://wapps.endress.com/applicator">https://wapps.endress.com/applicator</a></li> <li>■ On CD-ROM for local PC installation.</li> </ul>
Configurator <sup>temperature</sup>	<p>Software for selecting and configuring the product depending on the measuring task, supported by graphics. Includes a comprehensive knowledge database and calculation tools:</p> <ul style="list-style-type: none"> <li>■ For temperature competence</li> <li>■ Quick and easy design and sizing of temperature measuring points</li> <li>■ Ideal measuring point design and sizing to suit the processes and needs of a wide range of industries</li> </ul> <p>The Configurator is available: On request from your Endress+Hauser sales office on a CD-ROM for local PC installation.</p>
W@M	<p>Life cycle management for your plant W@M supports you with a wide range of software applications over the entire process: from planning and procurement, to the installation, commissioning and operation of the measuring devices. All the relevant device information, such as the device status, spare parts and device-specific documentation, is available for every device over the entire life cycle.</p> <p>The application already contains the data of your Endress+Hauser device. Endress+Hauser also takes care of maintaining and updating the data records.</p> <p>W@M is available:</p> <ul style="list-style-type: none"> <li>■ Via the Internet: <a href="http://www.endress.com/lifecyclemanagement">www.endress.com/lifecyclemanagement</a></li> <li>■ On CD-ROM for local PC installation.</li> </ul>
FieldCare	<p>FDT-based plant asset management tool from Endress+Hauser. It can configure all smart field units in your system and helps you manage them. By using the status information, it is also a simple but effective way of checking their status and condition.</p> <p> For details, see Operating Instructions BA00027S and BA00059S</p>

## System components

Accessories	Description
Field indicator RIA16	<p>The indicator records the analog measuring signal from the head transmitter and shows this on the display. The LC display shows the current measured value in digital form and as a bar graph indicating a limit value violation. The indicator is looped into the 4 to 20 mA circuit and gets the required energy from there.</p> <p> For details, see the "Technical Information" document TI00144R/09/en</p>
RN221N	<p>Active barrier with power supply for safe separation of 4-20 mA standard signal circuits. Offers bidirectional HART transmission.</p> <p> For details, see "Technical Information" TI00073R and Operating Instructions BA00202R</p>
RNS221	<p>Supply unit for powering two 2-wire measuring devices solely in the non-Ex area. Bidirectional communication is possible via the HART communication jacks.</p> <p> For details, see "Technical Information" TI00081R and Brief Operating Instructions KA00110R</p>

## Documentation

### Technical Information

- iTEMP temperature head transmitter:
  - TMT180, PC-programmable, single-channel, Pt100 (TI088R/09/en)
  - TMT181, PC-programmable, single-channel, RTD, TC, Ω, mV (TI00070R/09/en)
  - HART® TMT182, single-channel, RTD, TC, Ω, mV (TI078R/09/en)
  - HART® TMT82, two-channel, RTD, TC, Ω, mV (TI01010T/09/en)
  - PROFIBUS® PA TMT84, two-channel, RTD, TC, Ω, mV (TI138R/09/en)
  - FOUNDATION Fieldbus™ TMT85, two-channel, RTD, TC, Ω, mV (TI134R/09/en)
- Insert: Resistance thermometer iTHERM TS111 (TI01014T/09/en)

### Supplementary documentation ATEX/IECEX:

- Intrinsically safe Ex ia IIC (XA01024T/09/a3)
- Dust-explosion protection Ex ta/tb (XA01023T/09/a3)

[www.addresses.endress.com](http://www.addresses.endress.com)

---