

# Technical Information

## Micropilot FMR56, FMR57

Free space radar

### Level measurement in bulk solids



#### Application

- Continuous, non-contact level measurement in powdery to granular bulk solids
- PP-cladded horn antenna (FMR56); horn or parabolic antenna (FMR57)
- Maximum measuring range: 70 m (230 ft)
- Process temperature: -40 to +400 °C (-40 to 752 °F)
- Process pressure: -1 to +16 bar (-14.5 to +232 psi)
- Accuracy: ± 3 mm
- International explosion protection certificates
- Linearity protocol (3-point, 5-point)

#### Your benefits

- Reliable measurement even for changing product and process conditions
- HistoROM data management for easy commissioning, maintenance and diagnostics
- Highest reliability due to Multi-Echo Tracking
- SIL2 according to IEC 61508, SIL3 in case of homogeneous or heterogeneous redundancy
- Seamless integration into control or asset management systems
- Intuitive user interface in national languages
- *Bluetooth*<sup>®</sup> wireless technology for commissioning, operation and maintenance via free iOS / Android app SmartBlue
- Easy proof test for SIL
- Heartbeat Technology™

## Table of contents

<b>Important document information</b> . . . . .	<b>4</b>	Degree of protection . . . . .	50
Document function . . . . .	4	Vibration resistance . . . . .	50
Symbols used . . . . .	4	Cleaning the antenna . . . . .	50
<b>Terms and abbreviations</b> . . . . .	<b>5</b>	Electromagnetic compatibility (EMC) . . . . .	50
<b>Registered trademarks</b> . . . . .	<b>6</b>	<b>Process</b> . . . . .	<b>51</b>
<b>Function and system design</b> . . . . .	<b>7</b>	Process temperature, process pressure . . . . .	51
Measuring principle . . . . .	7	<b>Mechanical construction</b> . . . . .	<b>53</b>
<b>Input</b> . . . . .	<b>9</b>	Dimensions . . . . .	53
Measured variable . . . . .	9	Weight . . . . .	62
Measuring range . . . . .	9	Materials: Housing GT18 (stainless steel, corrosion-resistant) . . . . .	63
Operating frequency . . . . .	10	Materials: GT19 housing (plastic) . . . . .	64
Transmission power . . . . .	10	Materials: GT20 housing (die-cast aluminum, powder-coated) . . . . .	65
<b>Output</b> . . . . .	<b>11</b>	Materials: antenna and process connection . . . . .	66
Output signal . . . . .	11	Materials: Weather protection cover . . . . .	69
Signal on alarm . . . . .	12	<b>Operability</b> . . . . .	<b>70</b>
Linearization . . . . .	12	Operating concept . . . . .	70
Galvanic isolation . . . . .	12	Local operation . . . . .	71
Protocol-specific data . . . . .	12	Operation with remote display and operating module FHX50 . . . . .	71
<b>Power supply</b> . . . . .	<b>17</b>	Operation via Bluetooth® wireless technology . . . . .	72
Terminal assignment . . . . .	17	Remote operation . . . . .	73
Device plugs . . . . .	25	SupplyCare inventory management software . . . . .	76
Supply voltage . . . . .	26	<b>Certificates and approvals</b> . . . . .	<b>79</b>
Power consumption . . . . .	28	CE mark . . . . .	79
Current consumption . . . . .	28	RoHS . . . . .	79
Power supply failure . . . . .	29	RCM-Tick marking . . . . .	79
Potential equalization . . . . .	29	Ex approval . . . . .	79
Terminals . . . . .	29	Dual seal according to ANSI/ISA 12.27.01 . . . . .	79
Cable entries . . . . .	29	Functional safety . . . . .	79
Cable specification . . . . .	29	WHG . . . . .	79
Overvoltage protection . . . . .	30	Pressure equipment with allowable pressure ≤ 200 bar (2 900 psi) . . . . .	79
<b>Performance characteristics</b> . . . . .	<b>31</b>	Marine approval . . . . .	80
Reference operating conditions . . . . .	31	Radio standard EN 302729 . . . . .	80
Maximum measured error . . . . .	31	FCC . . . . .	81
Measured value resolution . . . . .	31	Industry Canada . . . . .	81
Response time . . . . .	32	Japanese radio approval . . . . .	81
Influence of ambient temperature . . . . .	32	CRN approval . . . . .	81
<b>Installation</b> . . . . .	<b>33</b>	Test, certificate . . . . .	83
Installation conditions . . . . .	33	Hard-copy product documentation . . . . .	83
Process conditions . . . . .	37	Other standards and guidelines . . . . .	84
Free-space installation in vessel . . . . .	37	<b>Ordering information</b> . . . . .	<b>85</b>
Container with heat insulation . . . . .	44	Ordering information . . . . .	85
<b>Environment</b> . . . . .	<b>45</b>	3-point linearity protocol . . . . .	86
Temperature range . . . . .	45	5-point linearity protocol . . . . .	87
Temperature limit . . . . .	45	Customer-specific configuration . . . . .	88
Storage temperature . . . . .	49	Tagging (TAG) . . . . .	88
Climate class . . . . .	49	Services . . . . .	88
Altitude according to IEC61010-1 Ed.3 . . . . .	50		

<b>Application packages</b> . . . . .	<b>89</b>
Heartbeat Diagnostics . . . . .	89
Heartbeat Verification . . . . .	90
Heartbeat Monitoring . . . . .	91
<b>Accessories</b> . . . . .	<b>92</b>
Device-specific accessories . . . . .	92
Communication-specific accessories . . . . .	99
Service-specific accessories . . . . .	100
System components . . . . .	100
<b>Supplementary documentation</b> . . . . .	<b>100</b>
Brief Operating Instructions (KA) . . . . .	100
Operating Instructions (BA) . . . . .	100
Safety Instructions (XA) . . . . .	100

## Important document information

### Document function

These Operating Instructions provide all of the information that is required in various phases of the life cycle of the device including:

- Product identification
- Incoming acceptance
- Storage
- Installation
- Connection
- Operation
- Commissioning
- Troubleshooting
- Maintenance
- Disposal

### Symbols used

#### Safety symbols



This symbol alerts you to a dangerous situation. Failure to avoid this situation will result in serious or fatal injury.



This symbol alerts you to a dangerous situation. Failure to avoid this situation can result in serious or fatal injury.



This symbol alerts you to a dangerous situation. Failure to avoid this situation can result in minor or medium injury.



This symbol contains information on procedures and other facts which do not result in personal injury.

#### Electrical symbols



Direct current



Alternating current



Direct current and alternating current



#### Ground connection

A grounded terminal which, as far as the operator is concerned, is grounded via a grounding system.



#### Protective earth (PE)

Ground terminals that must be connected to ground prior to establishing any other connections. The ground terminals are located on the inside and outside of the device.

- Interior ground terminal; protective earth is connected to the mains supply.
- Exterior ground terminal; device is connected to the plant grounding system.

#### Symbols for certain types of information and graphics



Procedures, processes or actions that are permitted



Procedures, processes or actions that are preferred



Procedures, processes or actions that are forbidden



Indicates additional information



Reference to graphic

▶  
Notice or individual step to be observed

1, 2, 3  
Series of steps

↳  
Result of a step

1, 2, 3, ...  
Item numbers

A, B, C, ...  
Views

 **Hazardous area**  
Indicates the hazardous area

 **Safe area (non-hazardous area)**  
Indicates the non-hazardous area

## Terms and abbreviations

**BA**  
Document type "Operating Instructions"

**KA**  
Document type "Brief Operating Instructions"

**SD**  
Document type "Special Documentation"

**XA**  
Document type "Safety Instructions"

**PN**  
Nominal pressure

**FieldCare**  
Scalable software tool for device configuration and integrated plant asset management solutions

**DeviceCare**  
Universal configuration software for Endress+Hauser HART, PROFIBUS, FOUNDATION Fieldbus and Ethernet field devices

**DTM**  
Device Type Manager

**DD**  
Device Description for HART communication protocol

$\epsilon_r$  (**Dk value**)  
Relative dielectric constant

**PLC**  
Programmable logic controller (PLC)

**CDI**  
Common Data Interface

**Operating tool**  
The term "operating tool" is used in place of the following operating software:  
■ FieldCare / DeviceCare, for operation via HART communication and PC  
■ SmartBlue (app), for operation using an Android or iOS smartphone or tablet

**MBP**  
Manchester Bus Powered

**PDU**  
Protocol Data Unit

## Registered trademarks

### **HART®**

Registered trademark of the FieldComm Group, Austin, Texas, USA

### **PROFIBUS®**

Registered trademark of the PROFIBUS User Organization, Karlsruhe, Germany

### **FOUNDATION™ Fieldbus**

Registration-pending trademark of the FieldComm Group, Austin, Texas, USA

### **Modbus®**

Registered trademark of SCHNEIDER AUTOMATION, INC.

### **Bluetooth®**

The *Bluetooth*® word mark and logos are registered trademarks owned by the Bluetooth SIG, Inc. and any use of such marks by Endress+Hauser is under license. Other trademarks and trade names are those of their respective owners.

### **Apple®**

Apple, the Apple logo, iPhone, and iPod touch are trademarks of Apple Inc., registered in the U.S. and other countries. App Store is a service mark of Apple Inc.

### **Android®**

Android, Google Play and the Google Play logo are trademarks of Google Inc.

### **KALREZ®, VITON®**

Registered trademarks of DuPont Performance Elastomers L.L.C., Wilmington, DE USA

### **TRI-CLAMP®**

Registered trademark of Ladish & Co., Inc., Kenosha, USA

## Function and system design

### Measuring principle

The Micropilot is a "downward-looking" measuring system, operating based on the time-of-flight method (ToF). It measures the distance from the reference point R (process connection of the measuring device) to the product surface. Radar pulses are emitted by an antenna, reflected off the product surface and received again by the radar system.

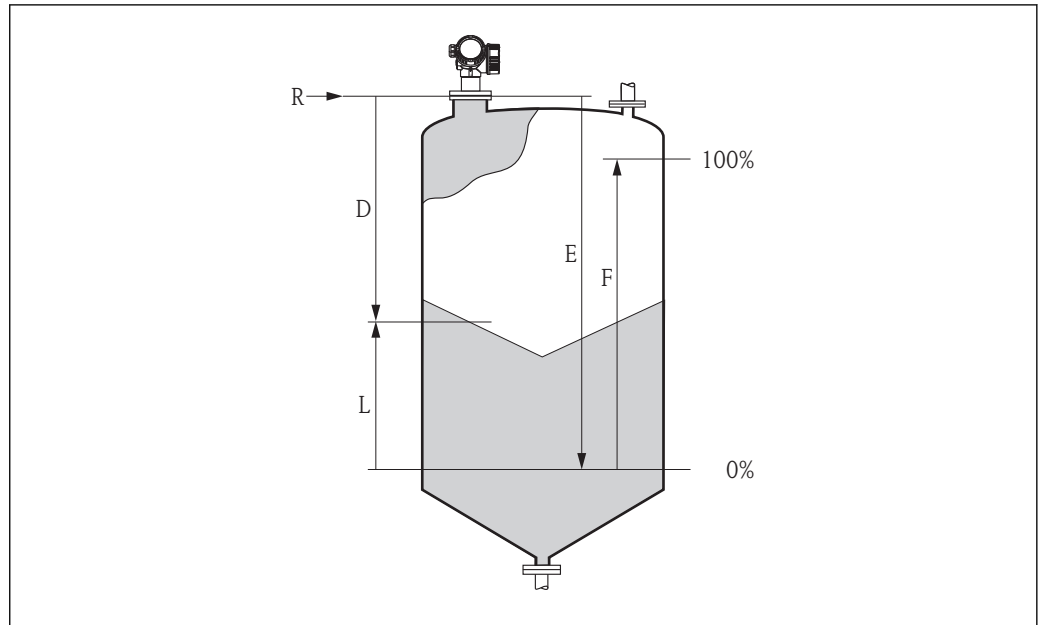

A0017872

1 Setup parameters of the Micropilot

- R Reference point of the measurement (lower edge of the flange or threaded connection)
- E Empty calibration (= zero)
- F Full calibration (= span)
- D Measured distance
- L Level ( $L = E - D$ )

### Input

The reflected radar impulses are received by the antenna and transmitted into the electronics. A microprocessor evaluates the signals and identifies the level echo caused by the reflection of the radar pulses at the product surface. The unambiguous signal identification is accomplished by the PulseMaster® eXact software together with the Multi-echo tracking algorithms, based on over 30 years of experience with time-of-flight technology.

The distance D to the product surface is proportional to the time of flight t of the impulse:

$$D = c \cdot t/2,$$

with c being the speed of light.

Based on the known empty distance E, the level L is calculated:

$$L = E - D$$

The Micropilot is equipped with functions to suppress interference echoes. The user can activate these functions. Together with the multi-echo tracking algorithms they ensure that interference echoes, e.g. from from internal fixtures and struts, are not interpreted as level echoes.

**Output**

The Micropilot is configured by entering the empty distance "E" (= zero), the full distance "F" (= span) and application parameters which automatically adapt the device to the process conditions. For models with a current output, the factory adjustment for zero point "E" and span "F" is 4 mA and 20 mA. For digital outputs and the display module, the factory adjustment for zero point "E" and span "F" is 0 % and 100 %.

A linearization function with max. 32 points, based on a table entered either manually or semi-automatically, can be activated locally or remotely. This function provides a measurement in engineering units and a linear output signal for spherical and horizontal cylindrical vessels and vessels with a conical outlet.

**Product life cycle****Planning**

- Universal measuring principle
- Measurement is independent of product properties
- Hardware and software developed according to SIL IEC 61508

**Procurement**

- As the global market leader in level measurement, Endress+Hauser guarantees the security of your investment
- Worldwide support and service

**Installation**

- No special tools are required
- Protection against reverse polarity
- Modern, detachable terminals
- Main electronics protected by a separate connection compartment

**Commissioning**

- Fast, menu-guided commissioning in only a few steps onsite or from the control room
- Plain text display in local language reduces the risk of error or confusion
- Direct local access to all parameters
- Printed Brief Operating Instructions in the device onsite

**Operation**

- Multi-echo tracking: Reliable measurement thanks to self-learning echo search algorithms taking into account the short-term and long-term history and plausibility of the detected signals to suppress interference echoes.
- In accordance with NAMUR NE107

**Maintenance**

- HistoROM: Data backup for device settings and measured values
- Exact device and process diagnostics to assist fast decisions with clear information regarding remedial action
- Intuitive, menu-guided operating concept in local language saves costs for training, maintenance and operation
- Cover of the electronics compartment can also be opened in the hazardous area

**Retirement**

- Order code translation for subsequent models
- RoHS-compliant (Restriction of certain Hazardous Substances), unleaded soldering of electronic components
- Environmentally friendly recycling approach



## Input

**Measured variable** The measured variable is the distance between the reference point and the product surface.  
The level is calculated based on "E", the empty distance entered.  
Optionally, the level can be converted to other variables (volume, mass) by linearization (32 points).

### Measuring range

#### Maximum measuring range

FMR56	Maximum measuring range
For all versions	30 m (98 ft)

FMR57	Maximum measuring range
For all versions	70 m (230 ft)

#### Usable measuring range

The usable measuring range depends on the antenna size, the medium's reflective properties, the installation position and any possible interference reflections.

Reduction of the max. possible measuring range by:

- Media with bad reflective properties (= low DC). For examples, see the table below.
- Angle of repose
- Extremely loose surfaces of bulk solids, e.g. bulk solids with low bulk weight in the case of pneumatic filling.
- Formation of buildup, particularly of moist products.

Media group	$\epsilon_r$	Examples
<b>A</b>	1.6 to 1.9	<ul style="list-style-type: none"> <li>▪ Plastic granulate</li> <li>▪ White lime, special cement</li> <li>▪ Sugar</li> </ul>
<b>B</b>	1.9 to 2.5	Portland cement, plaster
<b>C</b>	2.5 to 4	<ul style="list-style-type: none"> <li>▪ Grain, seeds</li> <li>▪ Ground stones</li> <li>▪ Sand</li> </ul>
<b>D</b>	4 to 7	<ul style="list-style-type: none"> <li>▪ Naturally moist (ground) stones, ores</li> <li>▪ Salt</li> </ul>
<b>E</b>	> 7	<ul style="list-style-type: none"> <li>▪ Metal powder</li> <li>▪ Carbon black</li> <li>▪ Coal dust</li> </ul>

For very loose or loosened bulk solids, the lower group applies in each case.

 For dielectric constants (DC values) of many media commonly used in various industries refer to:

- the Endress+Hauser DC manual (CP01076F)
- the Endress+Hauser "DC Values App" (available for Android and iOS)

**Operating frequency**

K-band (~ 26 GHz)

As the transmission pulses are statistically coded, up to 8 Micropilot transmitters can be installed in the same tank.

**Transmission power**

Distance	Mean power density in the direction of the beam
1 m (3.3 ft)	< 64 nW/cm <sup>2</sup>
5 m (16 ft)	< 2.5 nW/cm <sup>2</sup>

## Output

### Output signal

#### HART

- Signal coding:  
FSK  $\pm 0.5$  mA over current signal
- Data transmission rate:  
1 200 Bit/s
- Galvanic isolation:  
Yes

#### Bluetooth® wireless technology

- Device version:  
Order code 610 "Accessory mounted", option NF "Bluetooth"
- Operation / configuration:  
Via the *SmartBlue* app
- Range under reference conditions:  
> 10 m (33 ft)
- Encryption:  
Encrypted communication and password encryption prevent incorrect operation by unauthorized persons

#### PROFIBUS PA

- Signal coding:  
Manchester Bus Powered (MBP)
- Data transmission rate:  
31.25 kBit/s, Voltage mode
- Galvanic isolation:  
Yes

#### FOUNDATION Fieldbus

- Signal coding:  
Manchester Bus Powered (MBP)
- Data transmission rate:  
31.25 kBit/s, Voltage mode
- Galvanic isolation:  
Yes

#### Switch output



For HART devices, the switch output is available as an option.

- Function:  
Open collector switch output
- Switching behavior:  
Binary (conductive or non-conductive), switches when the programmable switch-on point/switch-off point is reached
- Failure mode:  
Non-conductive
- Electrical connection data:  
 $U = 16$  to  $35$  V<sub>DC</sub>,  $I = 0$  to  $40$  mA
- Internal resistor:  
 $R_i < 880$   $\Omega$   
The voltage drop at this internal resistor must be taken into account when planning the configuration. For example, the resulting voltage at a connected relay must be sufficient to switch the relay.
- Insulation voltages:  
Floating, insulation voltage  $1\,350$  V<sub>DC</sub> in relation to power supply and  $500$  V<sub>AC</sub> ground
- Switch point:  
User-programmable, separate for switch-on point and switch-off point
- Switching delay:  
User-programmable in the  $0$  to  $100$  s range, separate for switch-on point and switch-off point

- Scan rate:  
Corresponds to the measuring cycle
- Signal source / device variables:
  - Level linearized
  - Distance
  - Terminal voltage
  - Electronic temperature
  - Relative echo amplitude
  - Diagnostic values, advanced diagnostic blocks
  - Only for active interface measurement
- Number of switch cycles:  
Unlimited

**Signal on alarm**

Depending on the interface, failure information is displayed as follows:

- Current output
  - Choice of failure mode (in accordance with NAMUR Recommendation NE 43):  
Minimum alarm: 3.6 mA  
Maximum alarm (= factory setting): 22 mA
  - Failure mode with user-configurable value: 3.59 to 22.5 mA
- Local display
  - Status signal (as per NAMUR Recommendation NE 107)
  - Plain text display
- Operating tool via digital communication (HART, PROFIBUS PA, FOUNDATION Fieldbus) or service interface (CDI)
  - Status signal (as per NAMUR Recommendation NE 107)
  - Plain text display

**Linearization**

The device's linearization function allows the user to convert the measured value to any length or volume units. Linearization tables for calculating the volume in cylindrical vessels are preprogrammed into the device. Other linearization tables of up to 32 value pairs can be entered manually or semi-automatically.

**Galvanic isolation**

All circuits for the outputs are galvanically isolated from each other.

**Protocol-specific data****HART**

Manufacturer ID	17 (0x11)
Device type ID	0x1128
HART specification	7.0
Device description files (DTM, DD)	Information and files under: <ul style="list-style-type: none"> <li>▪ <a href="http://www.endress.com">www.endress.com</a></li> <li>▪ <a href="http://www.fieldcommgroup.org">www.fieldcommgroup.org</a></li> </ul>
HART load	min. 250 Ω

HART device variables	<p>The measured values can be freely assigned to the device variables.</p> <p><b>Measured values for PV (primary variable)</b></p> <ul style="list-style-type: none"> <li>▪ Level linearized</li> <li>▪ Distance</li> <li>▪ Electronic temperature</li> <li>▪ Relative echo amplitude</li> <li>▪ Area of incoupling</li> <li>▪ Analog output adv. diagnostics 1</li> <li>▪ Analog output adv. diagnostics 2</li> </ul> <p><b>Measured values for SV, TV, QV (second, third and fourth variable)</b></p> <ul style="list-style-type: none"> <li>▪ Level linearized</li> <li>▪ Distance</li> <li>▪ Electronic temperature</li> <li>▪ Terminal voltage</li> <li>▪ Relative echo amplitude</li> <li>▪ Absolute echo amplitude</li> <li>▪ Area of incoupling</li> <li>▪ Analog output adv. diagnostics 1</li> <li>▪ Analog output adv. diagnostics 2</li> </ul>
Supported functions	<ul style="list-style-type: none"> <li>▪ Burst mode</li> <li>▪ Additional transmitter status</li> </ul>

**Wireless HART data**

Minimum starting voltage	17.5 V
Start-up current	4 mA
Starting time	80 s
Minimum operating voltage	17.5 V
Multidrop current	4.0 mA
Time for connection setup	30 s

**PROFIBUS PA**

Manufacturer ID	17 (0x11)
Ident number	0x1559
Profile version	3.02
GSD file	Information and files under:
GSD file version	<ul style="list-style-type: none"> <li>▪ <a href="http://www.endress.com">www.endress.com</a></li> <li>▪ <a href="http://www.profibus.org">www.profibus.org</a></li> </ul>
Output values	<p><b>Analog Input:</b></p> <ul style="list-style-type: none"> <li>▪ Level linearized</li> <li>▪ Distance</li> <li>▪ Terminal voltage</li> <li>▪ Electronic temperature</li> <li>▪ Absolute echo amplitude</li> <li>▪ Relative echo amplitude</li> <li>▪ Analog output adv. diagnostics 1</li> <li>▪ Analog output adv. diagnostics 2</li> </ul> <p><b>Digital Input:</b></p> <ul style="list-style-type: none"> <li>▪ Digital output AD 1</li> <li>▪ Digital output AD 2</li> <li>▪ Switch output</li> </ul>

Input values	<p><b>Analog Output:</b></p> <ul style="list-style-type: none"> <li>▪ Analog value from PLC (for sensor block, external pressure to compensate for gas phase effects)</li> <li>▪ Analog value from PLC for transmission to display</li> </ul> <p><b>Digital Output:</b></p> <ul style="list-style-type: none"> <li>▪ Extended Diagnostic Block</li> <li>▪ Level Limiter</li> <li>▪ Sensor Block Measurement On</li> <li>▪ Sensor Block Save History On</li> <li>▪ Status output</li> </ul>
Supported functions	<ul style="list-style-type: none"> <li>▪ Identification &amp; Maintenance Simplest device identification on the part of the control system and nameplate</li> <li>▪ Automatic Ident Number Adoption GSD compatibility mode with predecessor Micropilot M FMR2xx</li> <li>▪ Physical Layer Diagnostics Installation check of the PROFIBUS segment and the Micropilot FMR5x using terminal voltage and message monitoring</li> <li>▪ PROFIBUS upload/download Reading and writing parameters is up to ten times faster with PROFIBUS upload/download</li> <li>▪ Condensed status Simplest and self-explanatory diagnostic information by categorizing diagnostic messages that occur</li> </ul>

#### FOUNDATION Fieldbus

Manufacturer ID	0x452B48
Device type	0x1028
Device revision	0x01
DD revision	Information and files under:
CFF revision	<ul style="list-style-type: none"> <li>▪ <a href="http://www.endress.com">www.endress.com</a></li> <li>▪ <a href="http://www.fieldcommgroup.org">www.fieldcommgroup.org</a></li> </ul>
Device Tester Version (ITK version)	6.0.1
ITK Test Campaign Number	IT085300
Link Master capability (LAS)	Yes
Choice of "Link Master" and "Basic Device"	Yes; Factory setting: Basic Device
Node address	Factory setting: 247 (0xF7)
Supported functions	<p>The following methods are supported:</p> <ul style="list-style-type: none"> <li>▪ Restart</li> <li>▪ ENP Restart</li> <li>▪ Setup</li> <li>▪ Linearization</li> <li>▪ Self Check</li> </ul>
<b>Virtual Communication Relationships (VCRs)</b>	
Number of VCRs	44
Number of link objects in VFD	50
Permanent entries	1
Client VCRs	0
Server VCRs	10
Source VCRs	43
Sink VCRs	0
Subscriber VCRs	43
Publisher VCRs	43
<b>Device Link Capabilities</b>	

Slot time	4
Min. delay between PDU	8
Max. response delay	20

*Transducer Blocks*

Block	Contents	Output values
Setup Transducer Block	Contains all the parameters for standard commissioning	<ul style="list-style-type: none"> <li>■ Level or volume (channel 1) (depending on the block configuration)</li> <li>■ Distance (channel 2)</li> </ul>
Advanced Setup Transducer Block	Contains all the parameters for more accurate measurement configuration	No output values
Display Transducer Block	Contains parameters to configure the onsite display	No output values
Diagnostic Transducer Block	Contains diagnostic information	No output values
Advanced Diagnostic Transducer Block	Contains parameters for advanced diagnostics	No output values
Expert Configuration Transducer Block	Contains parameters that require the user to have in-depth knowledge of the operation of the device in order to configure the parameters appropriately	No output values
Expert Information Transducer Block	Contains parameters that provide information about the state of the device	No output values
Service Sensor Transducer Block	Contains parameters that can only be accessed by Endress+Hauser Service	No output values
Service Information Transducer Block	Contains parameters that provide Endress+Hauser Service with information about the state of the device	No output values
Data Transfer Transducer Block	Contains parameters for backing up the device configuration in the display module and for writing the saved configuration to the device. Access to these parameters is reserved for Endress+Hauser Service.	No output values

*Function blocks*

Block	Contents	Number of permanent blocks	Number of instantiatable blocks	Execution time	Functionality
Resource Block	The Resource Block contains all the data that uniquely identify the device. It is an electronic version of a nameplate of the device.	1	0	-	Enhanced
Analog Input Block	The AI Block receives the measuring data from the Sensor Block (selectable via a channel number), and makes the data available to other blocks at its output.	2	3	25 ms	Enhanced
Discrete Input Block	The Discrete Input Block receives a discrete value (e.g. indicator that measuring range has been exceeded) and makes the value available for other blocks at the output.	1	2	20 ms	Standard

Block	Contents	Number of permanent blocks	Number of instantiatable blocks	Execution time	Functionality
Multiple Analog Output Block	The Multiple Analog Output Block is used to transmit analog values from the bus to the device.	1	0	20 ms	Standard
Multiple Discrete Output Block	The Multiple Discrete Output Block is used to transmit discrete values from the bus to the device.	1	0	20 ms	Standard
PID Block	The PID Block is used as a proportional-integral-derivative controller and can be used universally for closed-loop-control in the field. It enables cascade mode and feedforward control.	1	1	25 ms	Standard
Arithmetic Block	The Arithmetic Block is designed to permit simple use of popular measurement math functions. The user does not have to know how to write equations. The math algorithm is selected by name, chosen by the user for the function to be performed.	1	1	25 ms	Standard
Signal Characterizer Block	The Signal Characterizer Block has two sections, each with an output value that is a non-linear function of the input value. The non-linear function is generated by a single look-up table with 21 arbitrary x-y pairs.	1	1	25 ms	Standard
Input Selector Block	The Input Selector Block facilitates the selection of up to four inputs and generates an output value based on the configured action. This block normally receives its inputs from AI Blocks. The block enables the selection of maximum, minimum, average and 'first good' values.	1	1	25 ms	Standard
Integrator Block	The Integrator Block integrates a variable as a function of the time or accumulates the counts from a Pulse Input Block. The Block can be used as a totalizer that totalizes until a reset, or as a batch totalizer whereby the integrated value is compared against a target value generated before or during the control routine and generates a binary signal when the target value is reached.	1	1	25 ms	Standard
Analog Alarm Block		1	1	25 ms	Standard



Up to 20 blocks can be instantiated in the device altogether, including the blocks already instantiated.



## Power supply

### Terminal assignment

#### Terminal assignment 2-wire: 4-20 mA HART

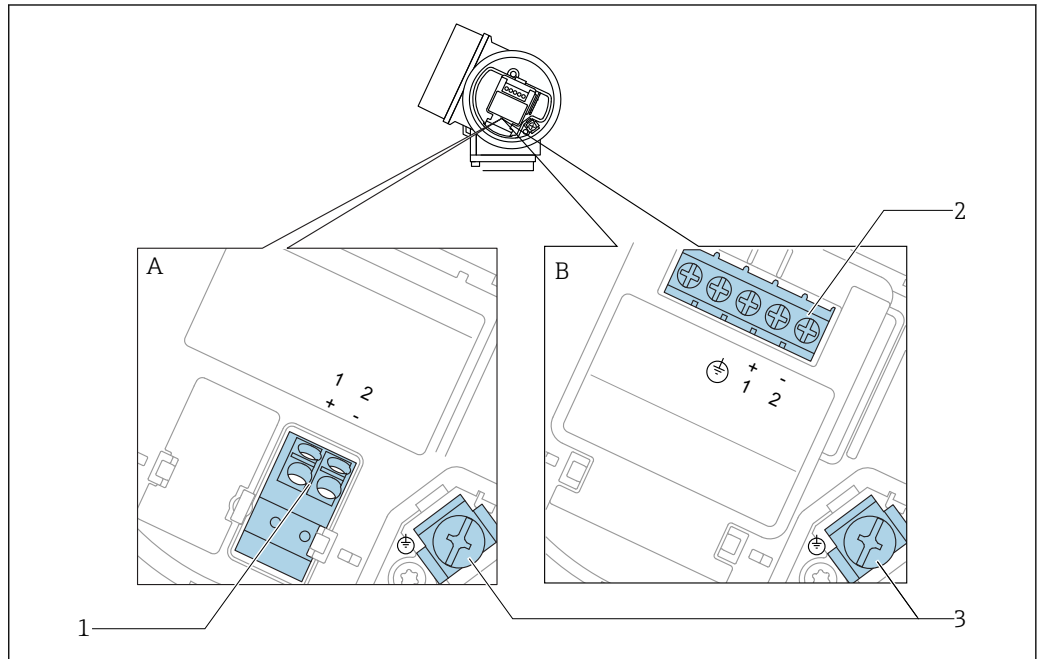

2 Terminal assignment 2-wire: 4-20 mA HART

A Without integrated overvoltage protection

B With integrated overvoltage protection

1 Connection 4-20 mA HART passive: terminals 1 and 2, without integrated overvoltage protection

2 Connection 4-20 mA HART passive: terminals 1 and 2, with integrated overvoltage protection

3 Terminal for cable screen

#### Block diagram 2-wire: 4-20 mA HART

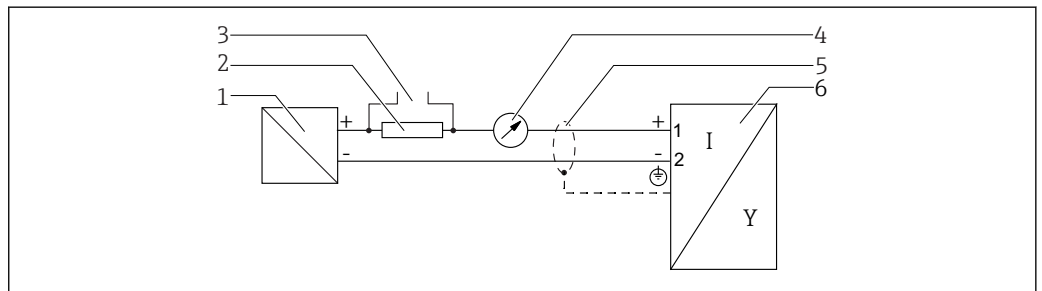

3 Block diagram 2-wire: 4-20 mA HART

1 Active barrier with power supply (e.g. RN221N); observe terminal voltage

2 HART communication resistor ( $\geq 250 \Omega$ ); observe maximum load

3 Connection for Commubox FXA195 or FieldXpert SFX350/SFX370 (via VIATOR Bluetooth modem)

4 Analog display device; observe maximum load

5 Cable screen; observe cable specification

6 Measuring device

**Terminal assignment 2-wire: 4-20 mA HART, switch output**

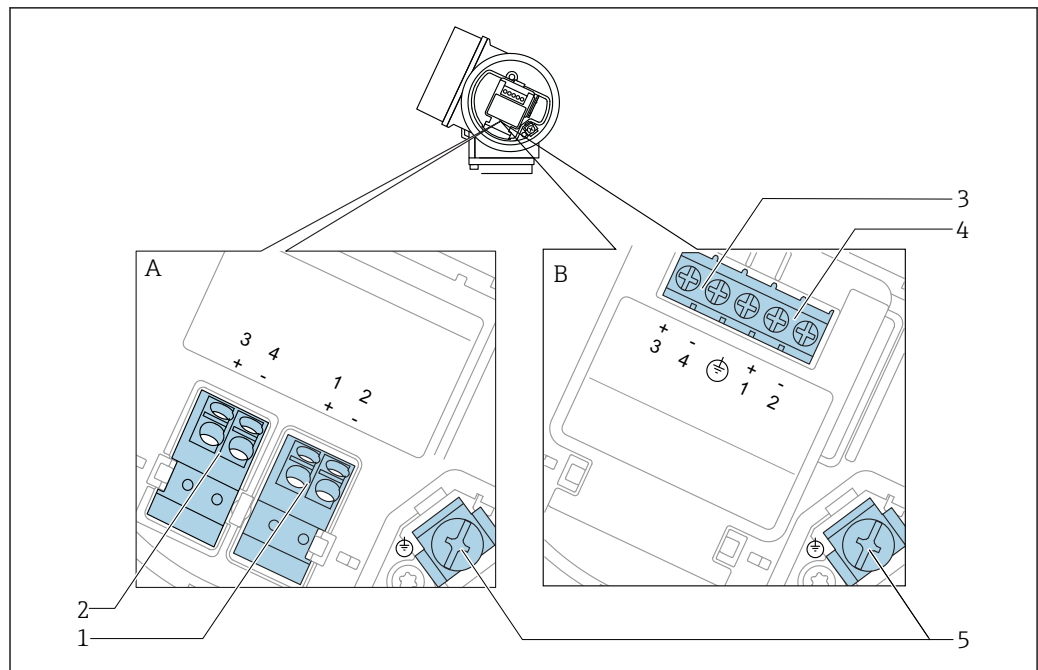

A0036500

**4** Terminal assignment 2-wire: 4-20 mA HART, switch output

A Without integrated overvoltage protection

B With integrated overvoltage protection

1 Connection 4-20 mA HART passive: terminals 1 and 2, without integrated overvoltage protection

2 Connection switch output (Open Collector): terminals 3 and 4, without integrated overvoltage protection

3 Connection switch output (Open Collector): terminals 3 and 4, with integrated overvoltage protection

4 Connection 4-20 mA HART passive: terminals 1 and 2, with integrated overvoltage protection

5 Terminal for cable screen

**Block diagram 2-wire: 4-20 mA HART, switch output**

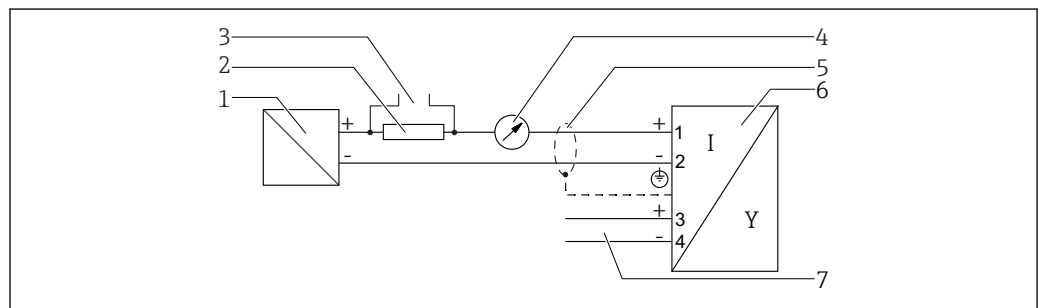

A0036501

**5** Block diagram 2-wire: 4-20 mA HART, switch output

1 Active barrier with power supply (e.g. RN221N); observe terminal voltage

2 HART communication resistor ( $\geq 250 \Omega$ ); observe maximum load

3 Connection for Commubox FXA195 or FieldXpert SFX350/SFX370 (via VIATOR Bluetooth modem)

4 Analog display device; observe maximum load

5 Cable screen; observe cable specification

6 Measuring device

7 Switch output (Open Collector)

**Terminal assignment 2-wire: 4-20 mA HART, 4-20 mA**

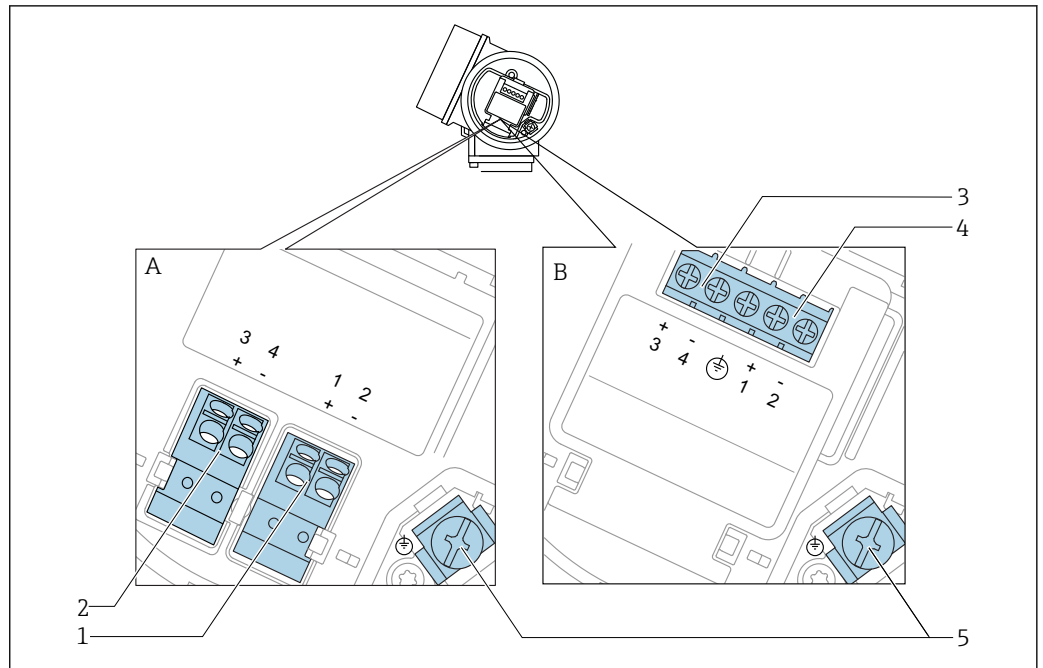

A0036500

6 Terminal assignment 2-wire: 4-20 mA HART, 4-20 mA

A Without integrated overvoltage protection

B With integrated overvoltage protection

1 Connection current output 1, 4-20 mA HART passive: terminals 1 and 2, without integrated overvoltage protection

2 Connection current output 2, 4-20 mA: terminals 3 and 4, without integrated overvoltage protection

3 Connection current output 2, 4-20 mA: terminals 3 and 4, with integrated overvoltage protection

4 Connection current output 1, 4-20 mA HART passive: terminals 1 and 2, with integrated overvoltage protection

5 Terminal for cable screen

**Block diagram 2-wire: 4-20 mA HART, 4-20 mA**

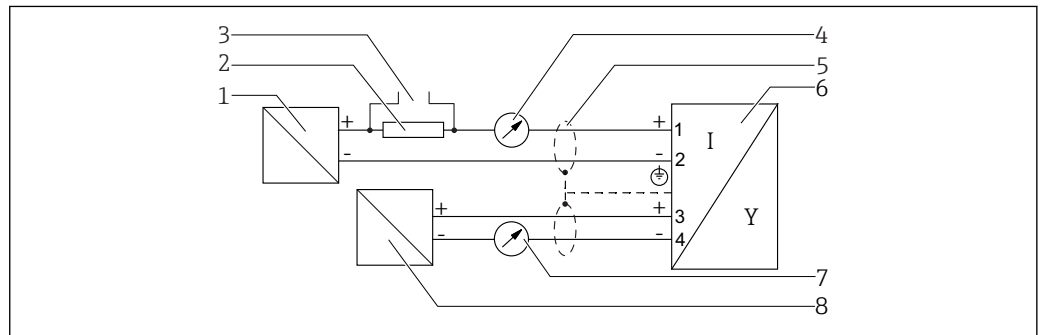

A0036502

7 Block diagram 2-wire: 4-20 mA HART, 4-20 mA

1 Active barrier with power supply (e.g. RN221N); observe terminal voltage

2 HART communication resistor ( $\geq 250 \Omega$ ); observe maximum load

3 Connection for Commubox FXA195 or FieldXpert SFX350/SFX370 (via VIATOR Bluetooth modem)

4 Analog display device; observe maximum load

5 Cable screen; observe cable specification

6 Measuring device

7 Analog display device; observe maximum load

8 Active barrier with power supply (e.g. RN221N), current output 2; observe terminal voltage

### Terminal assignment 4-wire: 4-20 mA HART (10.4 to 48 V<sub>DC</sub>)

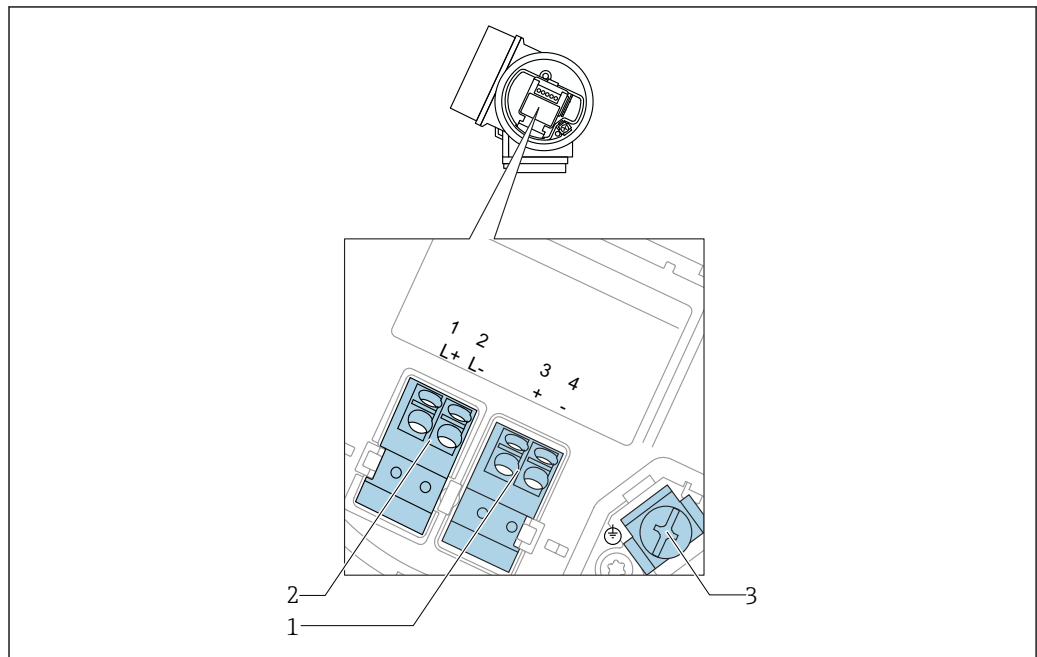

A0036516

#### 8 Terminal assignment 4-wire: 4-20 mA HART (10.4 to 48 V<sub>DC</sub>)

- 1 Connection 4-20 mA HART (active): terminals 3 and 4
- 2 Connection supply voltage: terminals 1 and 2
- 3 Terminal for cable screen

### Block diagram 4-wire: 4-20 mA HART (10.4 to 48 V<sub>DC</sub>)

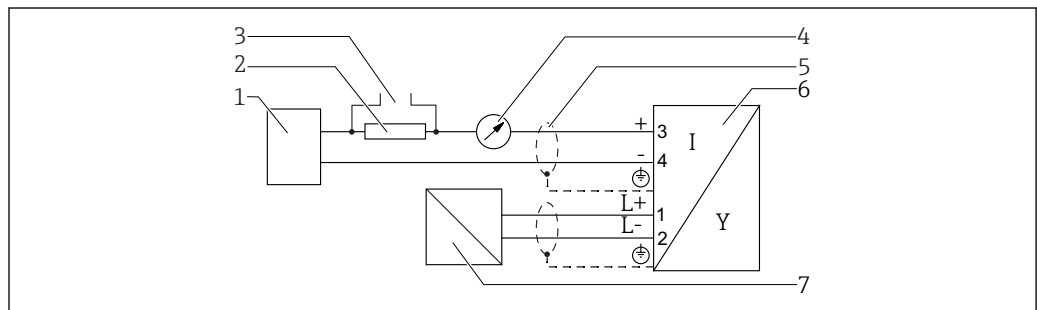

A0036526

#### 9 Block diagram 4-wire: 4-20 mA HART (10.4 to 48 V<sub>DC</sub>)

- 1 Evaluation unit, e.g. PLC
- 2 HART communication resistor ( $\geq 250 \Omega$ ); observe maximum load
- 3 Connection for Commubox FXA195 or FieldXpert SFX350/SFX370 (via VIATOR Bluetooth modem)
- 4 Analog display device; observe maximum load
- 5 Cable screen; observe cable specification
- 6 Measuring device
- 7 Supply voltage; observe terminal voltage, observe cable specification

**Terminal assignment 4-wire: 4-20 mA HART (90 to 253 V<sub>AC</sub>)**

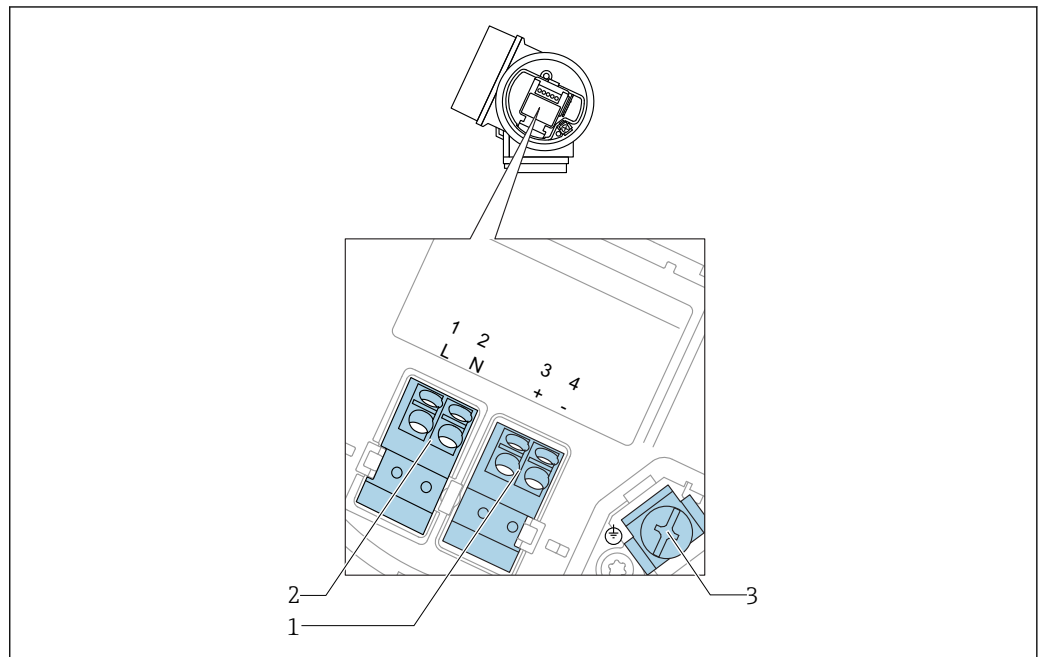

10 Terminal assignment 4-wire: 4-20 mA HART (90 to 253 V<sub>AC</sub>)

- 1 Connection 4-20 mA HART (active): terminals 3 and 4
- 2 Connection supply voltage: terminals 1 and 2
- 3 Terminal for cable screen

**CAUTION**

**To ensure electrical safety:**

- ▶ Do not disconnect the protective connection.
  - ▶ Disconnect the supply voltage before disconnecting the protective earth.
- i** Connect protective earth to the internal ground terminal (3) before connecting the supply voltage. If necessary, connect the potential matching line to the external ground terminal.
  - i** In order to ensure electromagnetic compatibility (EMC): Do **not** only ground the device via the protective earth conductor of the supply cable. Instead, the functional grounding must also be connected to the process connection (flange or threaded connection) or to the external ground terminal.
  - i** An easily accessible power switch must be installed in the proximity of the device. The power switch must be marked as a disconnecter for the device (IEC/EN61010).

**Block diagram 4-wire: 4-20 mA HART (90 to 253 V<sub>AC</sub>)**

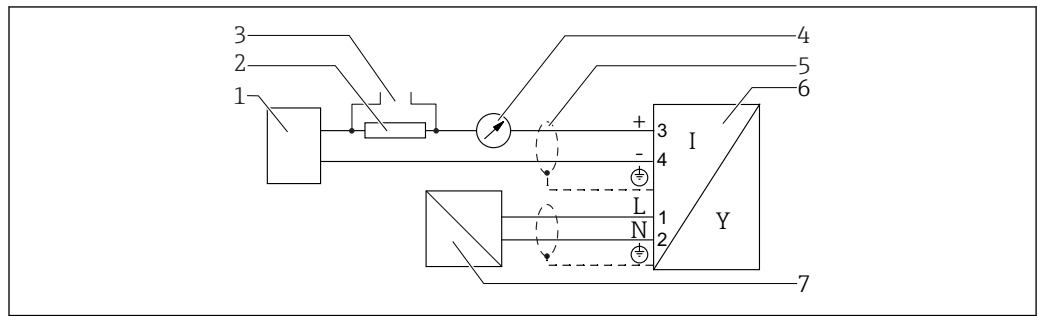

A0036527

11 Block diagram 4-wire: 4-20 mA HART (90 to 253 V<sub>AC</sub>)

- 1 Evaluation unit, e.g. PLC
- 2 HART communication resistor ( $\geq 250 \Omega$ ); observe maximum load
- 3 Connection for Commubox FXA195 or FieldXpert SFX350/SFX370 (via VIATOR Bluetooth modem)
- 4 Analog display device; observe maximum load
- 5 Cable scree; observe cable specification
- 6 Measuring device
- 7 Supply voltage; observe terminal voltage, observe cable specification

**Terminal assignment PROFIBUS PA / FOUNDATION Fieldbus**

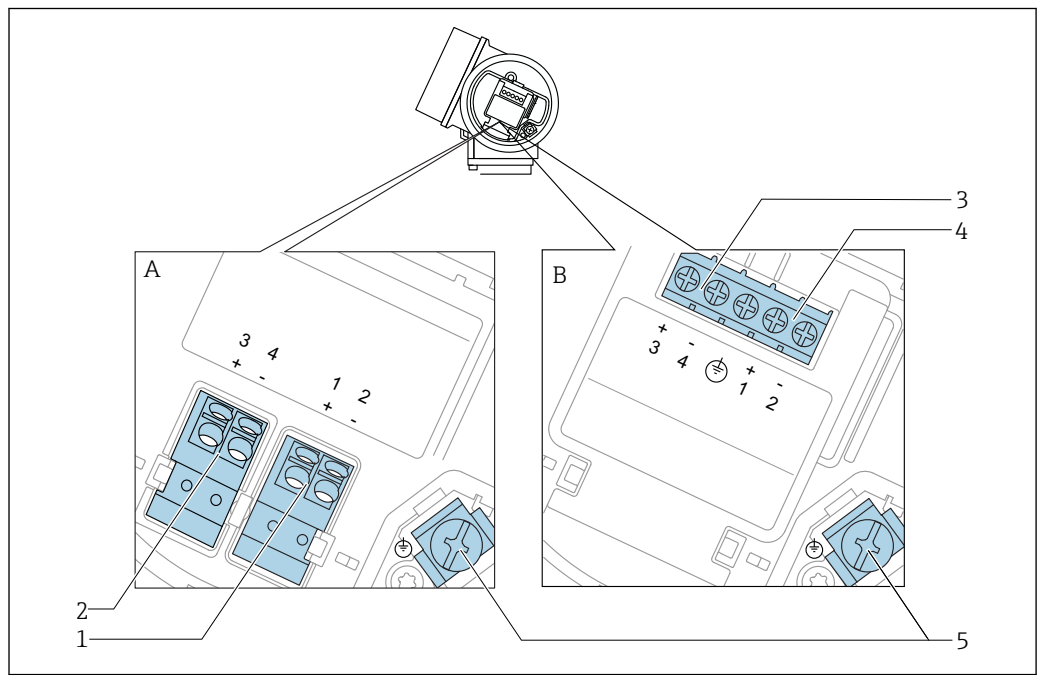

A0036500

12 Terminal assignment PROFIBUS PA / FOUNDATION Fieldbus

- A Without integrated overvoltage protection
- B With integrated overvoltage protection
- 1 Connection PROFIBUS PA / FOUNDATION Fieldbus: terminals 1 and 2, without integrated overvoltage protection
- 2 Connection switch output (Open Collector): terminals 3 and 4, without integrated overvoltage protection
- 3 Connection switch output (Open Collector): terminals 3 and 4, with integrated overvoltage protection
- 4 Connection PROFIBUS PA / FOUNDATION Fieldbus: terminals 1 and 2, with integrated overvoltage protection
- 5 Terminal for cable screen

**Block diagram PROFIBUS PA / FOUNDATION Fieldbus**

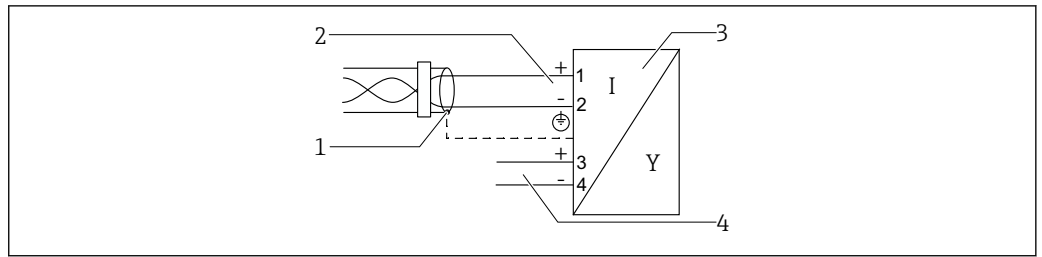

A0036530

13 Block diagram PROFIBUS PA / FOUNDATION Fieldbus

- 1 Cable screen; observe cable specifications
- 2 Connection PROFIBUS PA / FOUNDATION Fieldbus
- 3 Measuring device
- 4 Switch output (open collector)

### Connection examples for the switch output

**i** For HART devices, the switch output is available as an option.

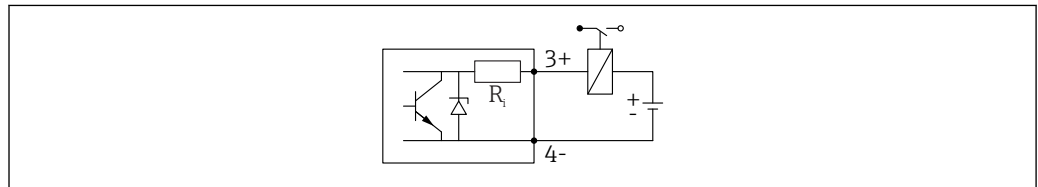

A0015909

**14** Connection of a relay

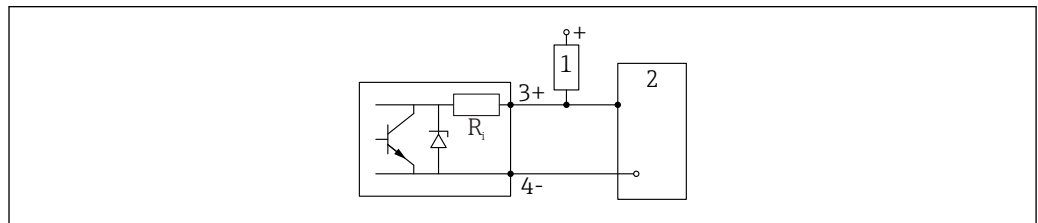

A0015910

**15** Connection to a digital input

- 1 Pull-up resistor
- 2 Digital input

**i** For optimum interference immunity we recommend to connect an external resistor (internal resistance of the relay or pull-up resistor) of  $< 1\,000\ \Omega$ .



**Device plugs**



In device versions with a device plug (M12 or 7/8"), it is not necessary to open the housing in order to connect the signal cable.

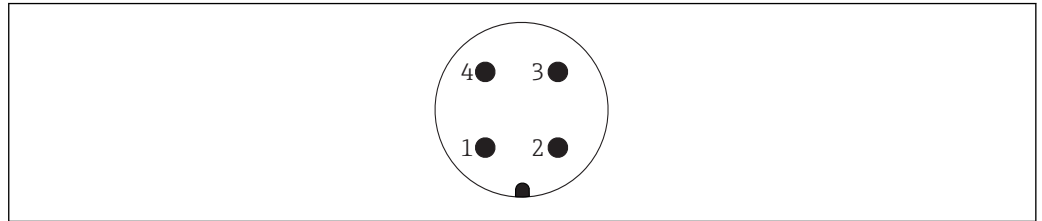

A0011175

16 Pin assignment of M12 plug

- 1 Signal +
- 2 Not assigned
- 3 Signal -
- 4 Ground

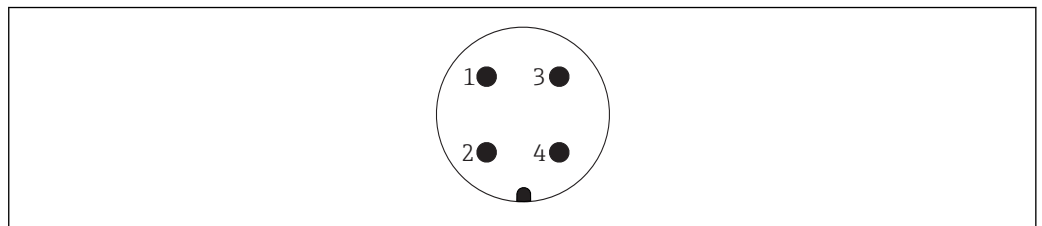

A0011176

17 Pin assignment of 7/8" plug

- 1 Signal -
- 2 Signal +
- 3 Not assigned
- 4 Shielding

**Supply voltage**

An external power supply is necessary.

 Various power supply units can be ordered from Endress+Hauser: see "Accessories" section

**2-wire, 4-20mA HART, passive**

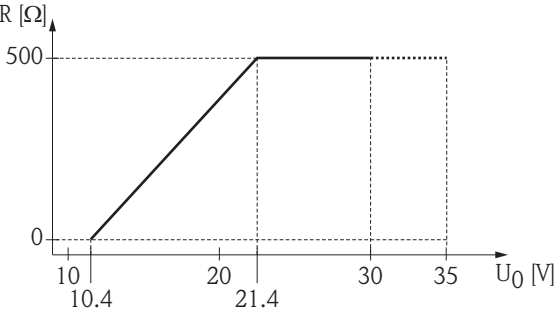
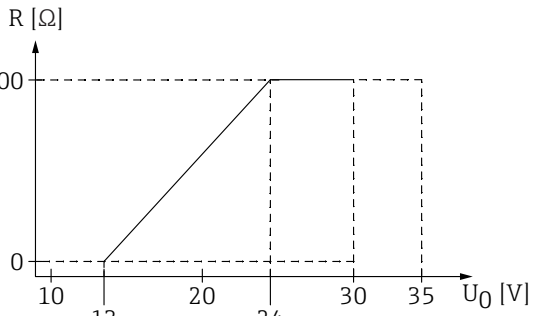
"Power supply, output" <sup>1)</sup>	"Approval" <sup>2)</sup>	Terminal voltage U at device	Maximum load R, depending on the supply voltage U <sub>0</sub> of the power supply unit
A: 2-wire; 4-20mA HART	<ul style="list-style-type: none"> <li>■ Non-Ex</li> <li>■ Ex nA</li> <li>■ Ex ic</li> <li>■ CSA GP</li> </ul>	10.4 to 35 V <sup>3) 4) 5)</sup>	
	Ex ia / IS	10.4 to 30 V <sup>3) 4) 5)</sup>	
	<ul style="list-style-type: none"> <li>■ Ex d(ia) / XP</li> <li>■ Ex ic(ia)</li> <li>■ Ex nA(ia)</li> <li>■ Ex ta / DIP</li> </ul>	13 to 35 V <sup>5) 6)</sup>	
	Ex ia + Ex d(ia) / IS + XP	13 to 30 V <sup>5) 6)</sup>	

- 1) Feature 020 in the product structure
- 2) Feature 010 in the product structure
- 3) At ambient temperatures T<sub>a</sub> ≤ -20 °C, a terminal voltage U ≥ 15 V is required to start the device with the minimum failure current (3.6 mA). The start-up current can be configured. If the device is operated with a fixed current I ≥ 5.5 mA (HART Multidrop mode), a voltage U ≥ 10.4 V suffices in the entire ambient temperature range.
- 4) A voltage U ≥ 12.5 V is required in the current simulation mode.
- 5) If the Bluetooth module is used, the minimum supply voltage increases by 3 V.
- 6) At ambient temperatures T<sub>a</sub> ≤ -20 °C, a terminal voltage U ≥ 16 V is required to start the device with the minimum failure current (3.6 mA).

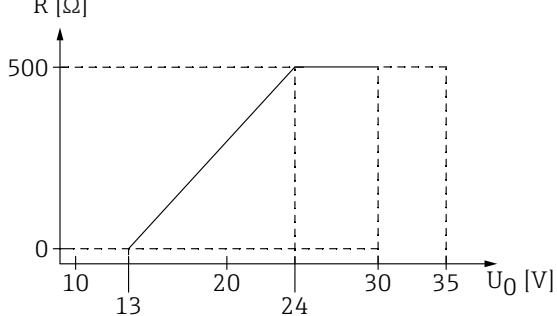
"Power supply, output" <sup>1)</sup>	"Approval" <sup>2)</sup>	Terminal voltage U at device	Maximum load R, depending on the supply voltage U <sub>0</sub> of the power supply unit
B: 2-wire; 4-20 mA HART, switch output	<ul style="list-style-type: none"> <li>■ Non-Ex</li> <li>■ Ex nA</li> <li>■ Ex nA(ia)</li> <li>■ Ex ic</li> <li>■ Ex ic(ia)</li> <li>■ Ex d(ia) / XP</li> <li>■ Ex ta / DIP</li> <li>■ CSA GP</li> </ul>	13 to 35 V <sup>3) 4)</sup>	
	<ul style="list-style-type: none"> <li>■ Ex ia / IS</li> <li>■ Ex ia + Ex d(ia) / IS + XP</li> </ul>	13 to 30 V <sup>3) 4)</sup>	

- 1) Feature 020 in the product structure
- 2) Feature 010 in the product structure
- 3) At ambient temperatures T<sub>a</sub> ≤ -30 °C, a terminal voltage U ≥ 16 V is required to start the device with the minimum failure current (3.6 mA).
- 4) If the Bluetooth module is used, the minimum supply voltage increases by 3 V.

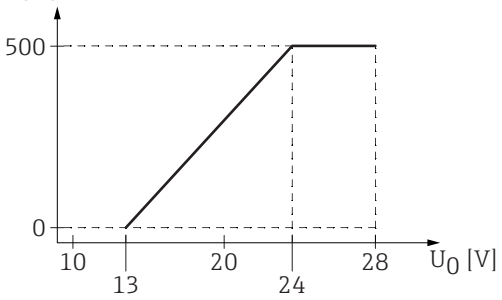
"Power supply, output" <sup>1)</sup>	"Approval" <sup>2)</sup>	Terminal voltage U at device	Maximum load R, depending on the supply voltage U <sub>0</sub> of the power supply unit
C: 2-wire; 4-20mA HART, 4-20mA	All	13 to 28 V <sup>3) 4)</sup>	 <p style="text-align: right; font-size: small;">A0034841</p>

- 1) Feature 020 in the product structure
- 2) Feature 010 in the product structure
- 3) At ambient temperatures  $T_a \leq -30\text{ }^\circ\text{C}$ , a terminal voltage  $U \geq 16\text{ V}$  is required to start the device with the minimum failure current (3.6 mA).
- 4) If the Bluetooth module is used, the minimum supply voltage increases by 3 V.

<b>Integrated polarity reversal protection</b>	Yes
<b>Permitted residual ripple with f = 0 to 100 Hz</b>	$U_{SS} < 1\text{ V}$
<b>Permitted residual ripple with f = 100 to 10000 Hz</b>	$U_{SS} < 10\text{ mV}$

**4-wire, 4-20mA HART, active**

"Power supply; output" <sup>1)</sup>	Terminal voltage U	Maximum load R <sub>max</sub>
<b>K:</b> 4-wire 90-253VAC; 4-20mA HART	90 to 253 V <sub>AC</sub> (50 to 60 Hz), overvoltage category II	500 Ω
<b>L:</b> 4-wire 10.4-48VDC; 4-20mA HART	10.4 to 48 V <sub>DC</sub>	

1) Feature 020 in the product structure

**PROFIBUS PA, FOUNDATION Fieldbus**

"Power supply; output" <sup>1)</sup>	"Approval" <sup>2)</sup>	Terminal voltage
<b>E:</b> 2-wire; FOUNDATION Fieldbus, switch output <b>G:</b> 2-wire; PROFIBUS PA, switch output	<ul style="list-style-type: none"> <li>▪ Non-Ex</li> <li>▪ Ex nA</li> <li>▪ Ex nA(ia)</li> <li>▪ Ex ic</li> <li>▪ Ex ic(ia)</li> <li>▪ Ex d(ia) / XP</li> <li>▪ Ex ta / DIP</li> <li>▪ CSA GP</li> </ul>	9 to 32 V <sup>3)</sup>
	<ul style="list-style-type: none"> <li>▪ Ex ia / IS</li> <li>▪ Ex ia + Ex d(ia) / IS + XP</li> </ul>	9 to 30 V <sup>3)</sup>

1) Feature 020 in the product structure

2) Feature 010 in the product structure

3) Input voltages up to 35 V do not damage the device.

<b>Polarity-dependent</b>	No
<b>FISCO/FNICO compliant according to IEC 60079-27</b>	Yes

**Power consumption**

"Power supply; Output" <sup>1)</sup>	Power consumption
<b>A:</b> 2-wire; 4-20mA HART	< 0.9 W
<b>B:</b> 2-wire; 4-20mA HART, switch output	< 0.9 W
<b>C:</b> 2-wire; 4-20mA HART, 4-20mA	< 2 x 0.7 W
<b>K:</b> 4-wire 90-253VAC; 4-20mA HART	6 VA
<b>L:</b> 4-wire 10.4-48VDC; 4-20mA HART	1.3 W

1) Feature 020 of the product structure

**Current consumption****HART**

<b>Nominal current</b>	3.6 to 22 mA, the start-up current for multidrop mode can be parametrized (is set to 3.6 mA on delivery)
<b>Breakdown signal (NAMUR NE43)</b>	adjustable: 3.59 to 22.5 mA

**PROFIBUS PA**

<b>Nominal current</b>	14 mA
<b>Failure current FDE (Fault Disconnection Electronic)</b>	0 mA

**FOUNDATION Fieldbus**

Device basic current	15 mA
Failure current FDE (Fault Disconnection Electronic)	0 mA

**FISCO**

$U_i$	17.5 V
$I_i$	550 mA
$P_i$	5.5 W
$C_i$	5 nF
$L_i$	10 $\mu$ H

**Power supply failure**

- Configuration is retained in the HistoROM (EEPROM).
- Error messages (incl. value of operated hours counter) are stored.

**Potential equalization**

No special measures for potential equalization are required.



If the device is designed for hazardous areas, observe the information in the documentation "Safety Instructions" (XA).

**Terminals**

- **Without integrated overvoltage protection**  
Plug-in spring terminals for wire cross-sections 0.5 to 2.5 mm<sup>2</sup> (20 to 14 AWG)
- **With integrated overvoltage protection**  
Screw terminals for wire cross-sections 0.2 to 2.5 mm<sup>2</sup> (24 to 14 AWG)

**Cable entries**

**Connection of the power supply and signal cables**

To be selected in feature 050 "Electrical connection":

- Coupling M20, material depends on approval:
  - For non-Ex, ATEX, IECEx, NEPSI Ex ia/ic:  
Plastic M20x1.5 for cable  $\varnothing$ 5 to 10 mm (0.2 to 0.39 in)
  - For Dust-Ex, FM IS, CSA IS, CSA GP, Ex ec:
  - For Ex db:  
No cable gland available
- Thread
  - 1/2" NPT
  - G 1/2"
  - M20 x 1.5
- M12 plug / 7/8" plug  
Only available for non-Ex, Ex ic, Ex ia

**Connection of remote display FHX50**

Feature 030 "Display, operation"	Cable entry for connection of FHX50
L: "Prepared for display FHX50 + M12 connection"	M12 socket
M: "Prepared for display FHX50 + M16 cable gland, custom connection"	M12 cable gland
N: "Prepared for display FHX50 + NPT1/2 thread, custom connection"	Thread NPT1/2

**Cable specification**

- **Devices without integrated overvoltage protection**  
Pluggable spring-force terminals for wire cross-sections 0.5 to 2.5 mm<sup>2</sup> (20 to 14 AWG)
- **Devices with integrated overvoltage protection**  
Screw terminals for wire cross-sections 0.2 to 2.5 mm<sup>2</sup> (24 to 14 AWG)
- For ambient temperature  $T_U \geq 60$  °C (140 °F): use cable for temperature  $T_U + 20$  K.

**HART**

- A normal device cable suffices if only the analog signal is used.
- A shielded cable is recommended if using the HART protocol. Observe grounding concept of the plant.
- For 4-wire devices: Standard device cable is sufficient for the power line.

**PROFIBUS**

Use a twisted, screened two-wire cable, preferably cable type A.

-  For further information on the cable specifications, see Operating Instructions BA00034S "PROFIBUS DP/PA: Guidelines for planning and commissioning", PNO Guideline 2.092 "PROFIBUS PA User and Installation Guideline" and IEC 61158-2 (MBP).

**FOUNDATION Fieldbus**

Endress+Hauser recommends using twisted, shielded two-wire cables.

-  For further information on the cable specifications, see Operating Instructions BA00013S "FOUNDATION Fieldbus Overview", FOUNDATION Fieldbus Guideline and IEC 61158-2 (MBP).

**Overvoltage protection**

If the measuring device is used for level measurement in flammable liquids which requires the use of overvoltage protection according to DIN EN 60079-14, standard for test procedures 60060-1 (10 kA, pulse 8/20 µs), an overvoltage protection module has to be installed.

**Integrated overvoltage protection module**

An integrated overvoltage protection module is available for 2-wire HART as well as PROFIBUS PA and FOUNDATION Fieldbus devices.

Product structure: Feature 610 "Accessory mounted", option NA "Overvoltage protection".

Technical data	
Resistance per channel	2 × 0.5 Ω max.
Threshold DC voltage	400 to 700 V
Threshold impulse voltage	< 800 V
Capacitance at 1 MHz	< 1.5 pF
Nominal arrest impulse voltage (8/20 µs)	10 kA

**External overvoltage protection module**

HAW562 or HAW569 from Endress+Hauser are suited as external overvoltage protection.

## Performance characteristics

**Reference operating conditions**

- Temperature = +24 °C (+75 °F) ±5 °C (±9 °F)
- Pressure = 960 mbar abs. (14 psia) ±100 mbar (±1.45 psi)
- Humidity = 60 % ±15 %
- Reflector: metal plate with a diameter ≥ 1 m (40 in)
- No major interference reflections inside the signal beam

**Maximum measured error**

Typical data under reference operating conditions: DIN EN IEC 61298-2 / DIN EN IEC 60770-1; percentage values in relation to the span.

Device version	Value	Output	
		digital	analog <sup>1)</sup>
Standard	Sum of non-linearity, non-repeatability and hysteresis	± 3 mm (0.12 in)	± 0.02 %
	Offset/Zero	± 4 mm (0.2 in)	± 0.03 %

1) Only relevant for 4-20mA current output; add error of the analog value to the digital value

**Differing values in near-range applications**

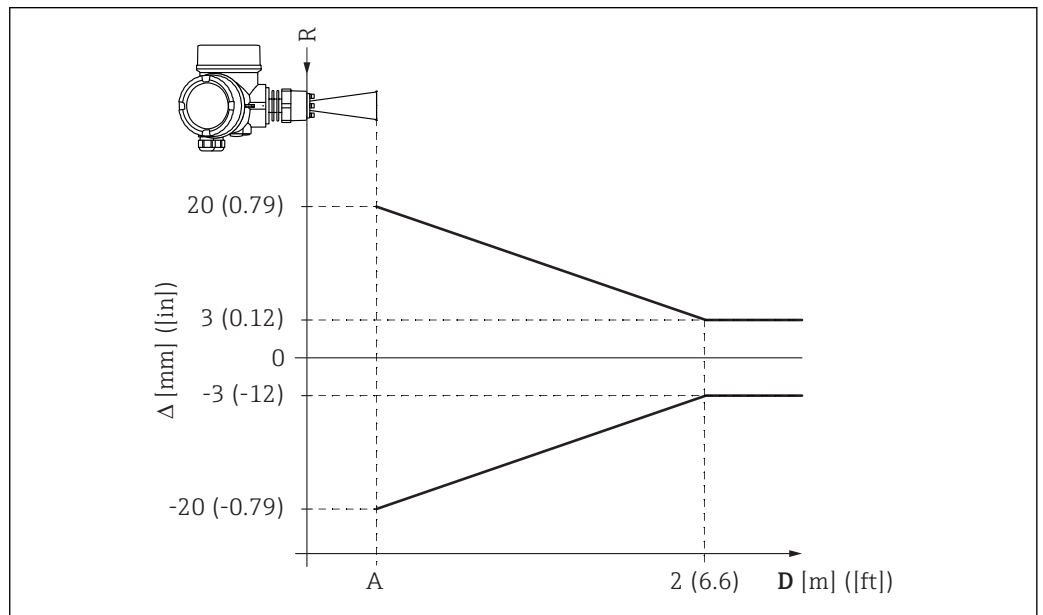

18 Maximum measured error in near-range applications

- Δ Maximum measured error
- A Lower edge of the antenna
- D Distance from the lower edge A of the antenna
- R Reference point of the distance measurement

**Measured value resolution**

Dead band according to DIN EN IEC 61298-2 / DIN EN IEC 60770-1:

- Digital: 1 mm
- Analog: 1 μA

**Response time**

The response time can be configured. The following step response times (in accordance with DIN EN IEC 61298-2 / DIN EN IEC 60770-1)<sup>1)</sup> are when damping is switched off:

Tank height	Sampling rate	Response time
< 10 m (33 ft)	$\geq 3.6 \text{ s}^{-1}$	< 0.8 s
< 70 m (230 ft)	$\geq 2.2 \text{ s}^{-1}$	< 1 s

**Influence of ambient temperature**

**The measurements are performed according to DIN EN IEC 61298-3 / DIN EN IEC 60770-1**

- Digital (HART, PROFIBUS PA, FOUNDATION Fieldbus): average  $T_C = 3 \text{ mm}/10 \text{ K}$
- Analog (current output):
  - Zero point (4 mA): average  $T_C = 0.02 \text{ \%}/10 \text{ K}$
  - Span (20 mA): average  $T_C = 0.05 \text{ \%}/10 \text{ K}$

1) According to DIN EN IEC 61298-2 / DIN EN IEC 60770-1, the step response time is the time that elapses after an abrupt change in the input signal until the change in the output signal has adopted 90% of the steady-state value for the first time.



## Installation

### Installation conditions

### Orientation

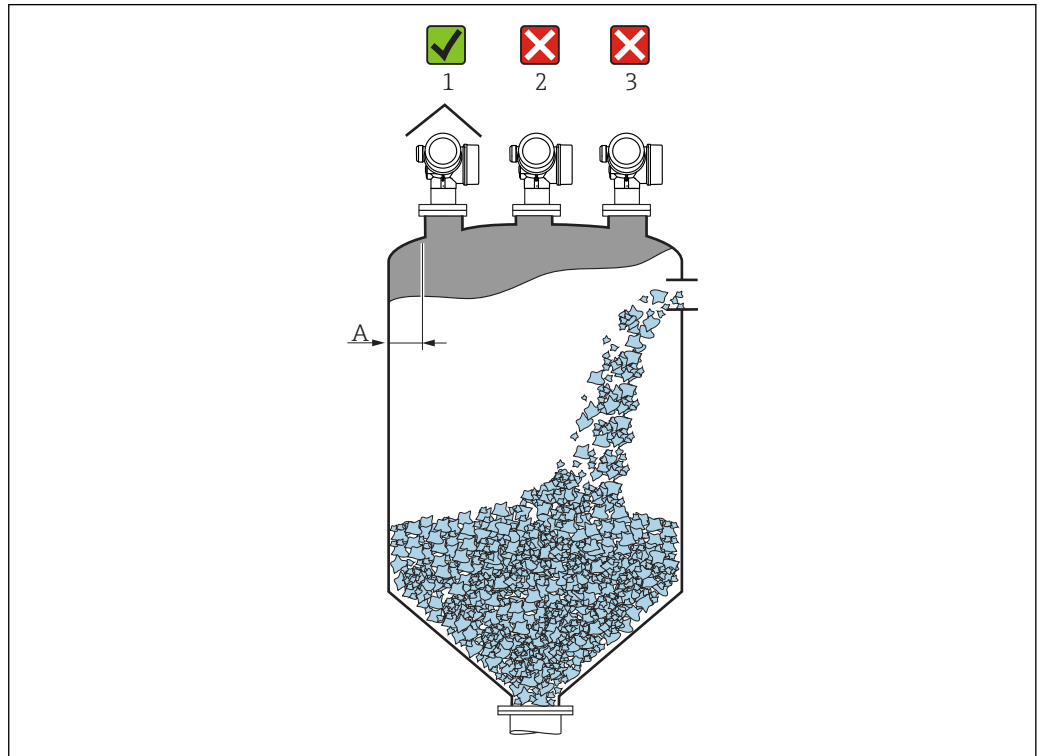

- Recommended distance **A** wall - nozzle outer edge:  $\sim 1/6$  of the vessel diameter. However, the device must not under any circumstances be mounted closer than 20 cm (7.87 in) to the vessel wall.  
 If the vessel wall is not smooth (corrugated iron, welding seams, joints, etc.) it is recommended to maintain the largest possible distance from the wall. Where necessary use an alignment unit to avoid interference reflections from the vessel wall.
- Not in the center (2) as interference can cause signal loss.
- Not above the filling curtain (3).
- The use of a weather protection cover (1) is recommended to protect the transmitter from direct sunlight or rain.
- In applications with strong dust emissions, the integrated purge air connection can prevent the antenna from becoming clogged.

## Internal vessel fittings

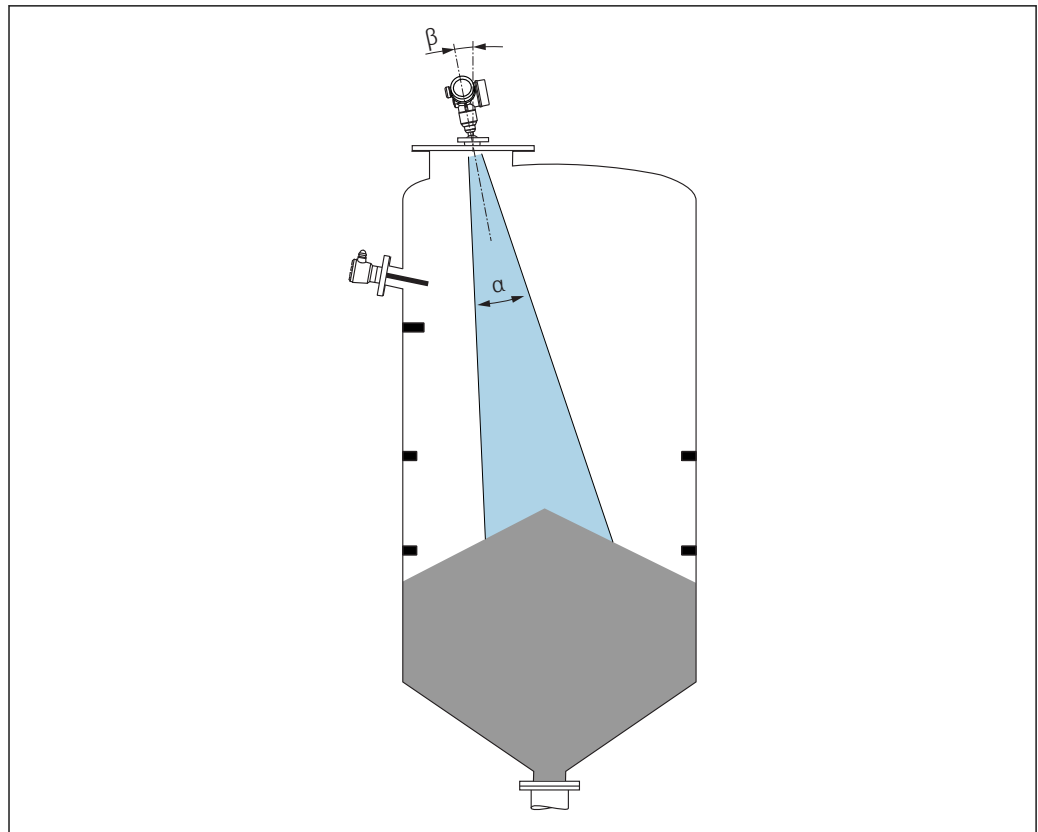

A0018946

Avoid the location of internal fittings (limit switches, temperature sensors, struts etc.) inside the signal beam. Take the beam angle into account.

### Avoiding interference echoes

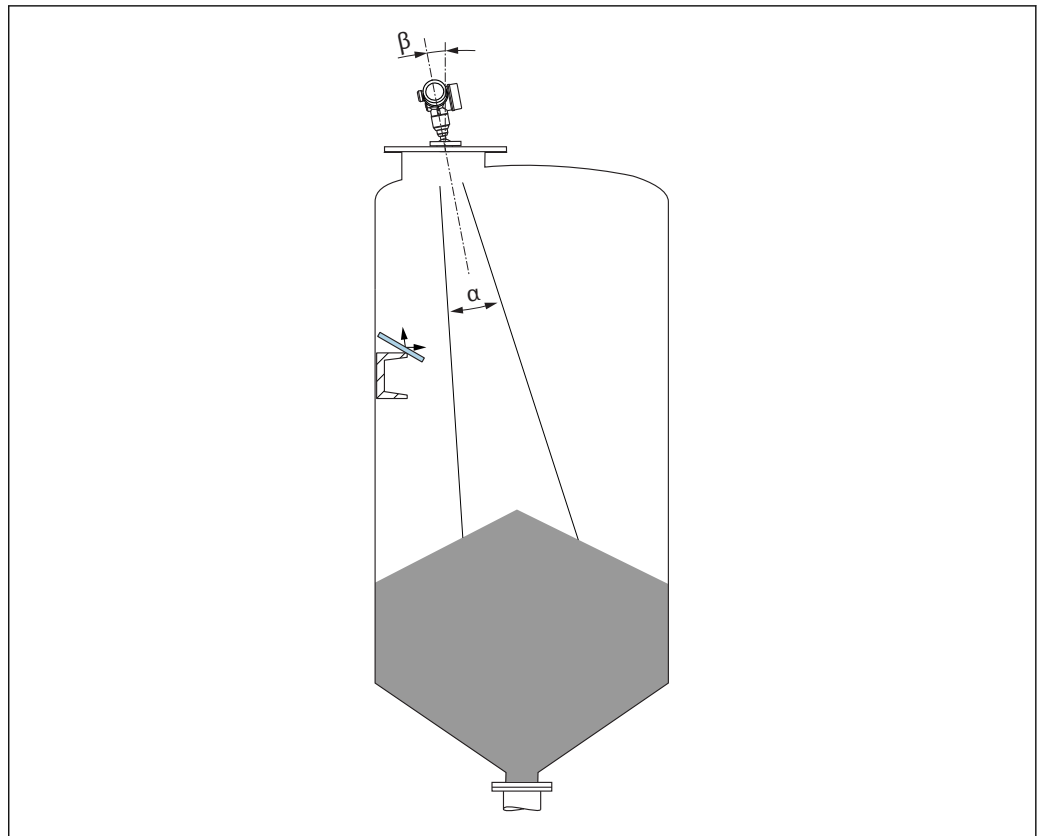

A0016889

Metal orifice plates, installed at an angle to scatter the radar signals, help prevent interference echoes

### Measurement in a plastic vessel

If the outer wall of the vessel is made of a non-conductive material (e.g. GFRP) microwaves can also be reflected off interfering installations outside of the vessel (e.g. metallic pipes (1), ladders (2), grates (3) etc.). Therefore there should be no such interfering installations in the signal beam.

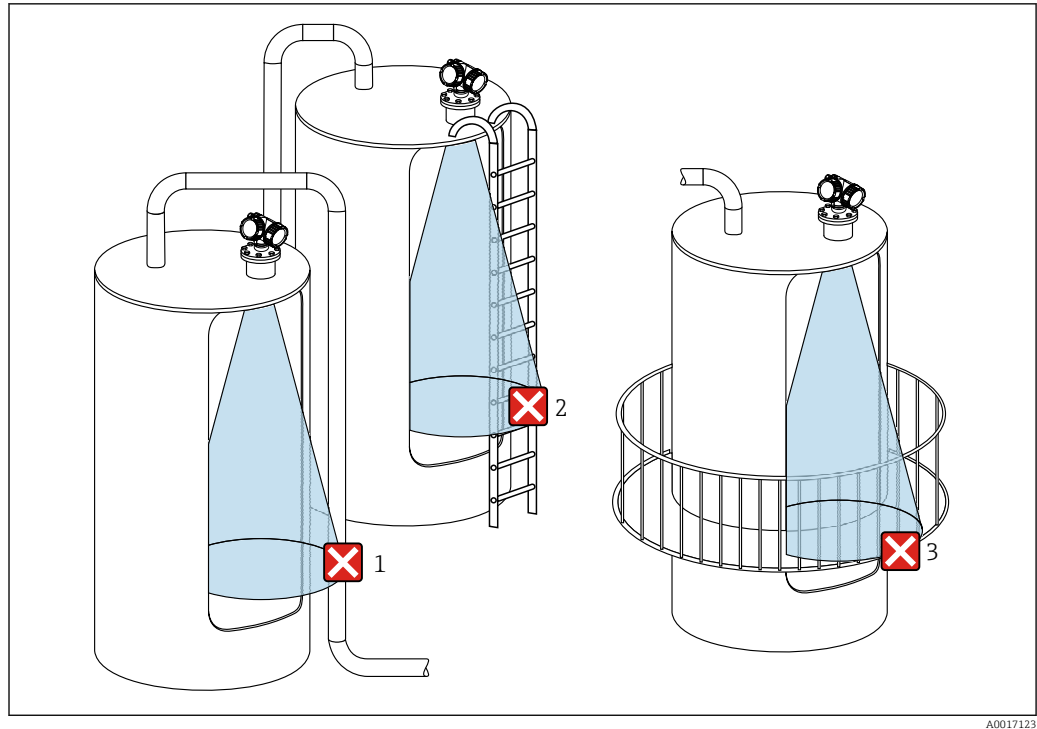

A0017123

### Optimization options

- Antenna size  
The larger the antenna the smaller the beam angle  $\alpha$ , resulting in fewer interference echoes.
- Interference echo suppression (mapping)  
Measurement can be optimized by electronically suppressing interference echoes
- Take into account the orientation of the antenna, the marking on the flange or threaded connection
- Metallic plates mounted at an angle  
These plates scatter the radar signals and can therefore reduce interference echoes.
- Variable flange seal (FMR56)  
The device can be aligned with the product surface using the adjustable flange seal.
- Alignment unit for FMR57  
In the case of devices with an alignment unit, the sensor can be optimally aligned to suit conditions in the vessel in order to prevent interference reflections. The maximum angle  $\beta$  is  $\pm 15^\circ$ .  
The purpose of sensor alignment is primarily to:
  - Prevent interference reflections
  - Increase the maximum possible measuring range in conical outlets

### Beam angle

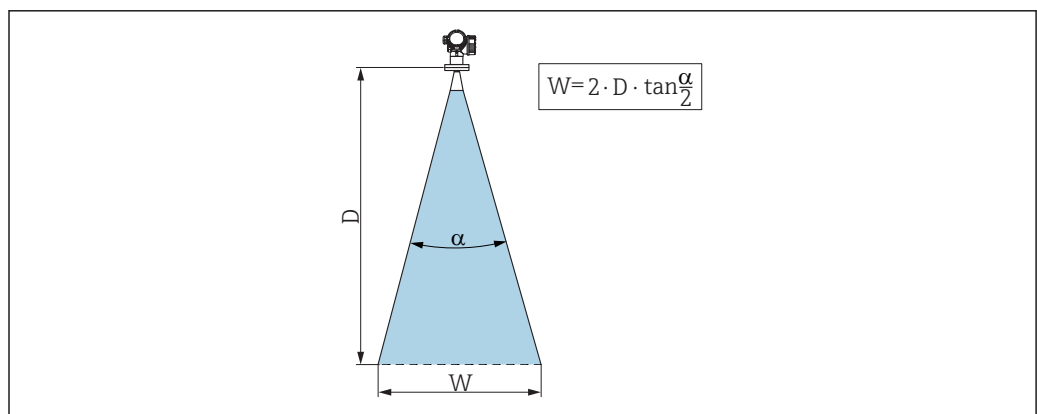

A0016891

19 Relationship between beam angle  $\alpha$ , distance  $D$  and beamwidth diameter  $W$

The beam angle is defined as the angle  $\alpha$  where the energy density of the radar waves reaches half the value of the maximum energy density (3dB width). Microwaves are also emitted outside the signal beam and can be reflected off interfering installations.

Beam diameter  $W$  as a function of beam angle  $\alpha$  and distance  $D$ .

**Antenna horn 100 mm (4 in),  $\alpha$  8°**

$$W = D \times 0.14$$

**Antenna horn 200 mm (8 in),  $\alpha$  10°**

$$W = D \times 0.18$$

**Parabolic antenna 200 mm (8 in),  $\alpha$  4°**

$$W = D \times 0.07$$

**Parabolic antenna 250 mm (10 in),  $\alpha$  3.5°**

$$W = D \times 0.06$$

#### Process conditions

- The measuring range begins where the beam hits the bottom. Levels below this point cannot be detected, particularly in the case of conical outlets. The maximum measuring range in such applications can be increased by using an alignment unit.
- In the case of media with a low  $\epsilon_r = 1.5$  to 2.5, the tank bottom may be visible through the medium at low levels. To ensure the necessary level of accuracy, we recommend positioning the zero point at a distance  $C$  above the floor (see Figure) in these applications.
-  The dielectric constants ( $\epsilon_r$  values) for many key media used in industry are provided in the DC Manual (CP00019F) and in Endress+Hauser's "DC Values App" (available for Android and iOS).
- In principle it is possible to measure up to the tip of the antenna with the Micropilot. However, due to considerations regarding abrasion and build-up, and depending on the orientation of the product (angle of repose), the end of the measuring range should be at a distance  $A$  (see Figure) from the tip of the antenna. If required, and if conditions are met (high  $\epsilon_r$  value, flat angle of repose), shorter distances can be achieved.

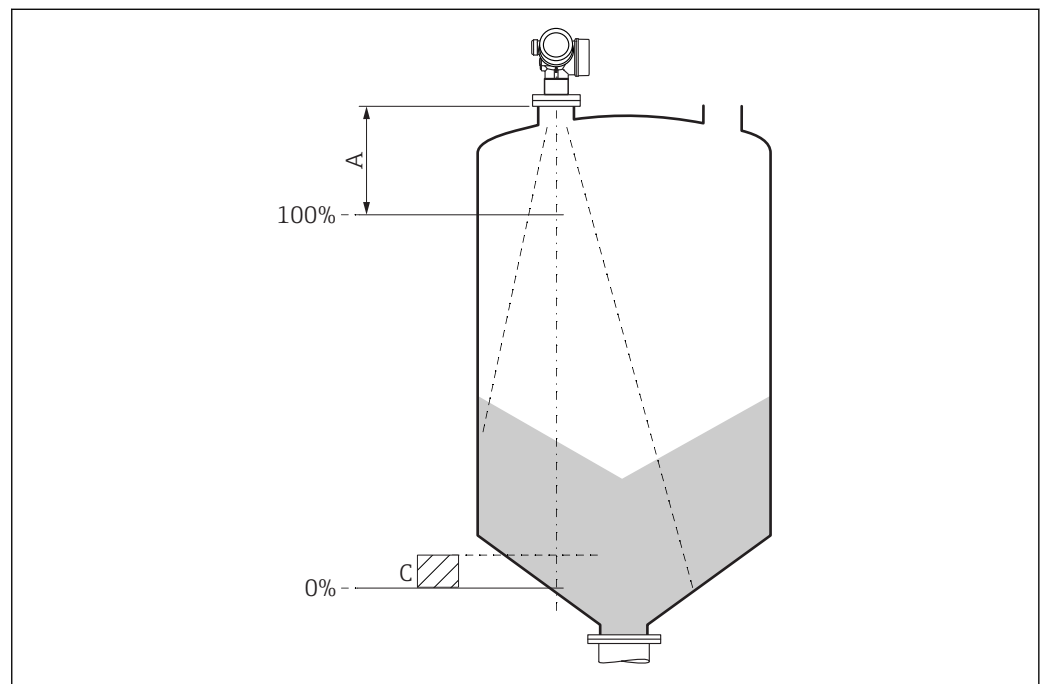

A0042712

$A$  400 mm (15.7 in)

$C$  50 to 150 mm (1.97 to 5.91 in)

#### Free-space installation in vessel

#### Horn antenna with slip-on flange (FMR56)

##### Alignment

-  If using the Micropilot with a slip-on flange in explosion-hazardous areas, observe all the specifications in the relevant Safety Instructions (XA).

- Align the antenna so that it is perpendicular to the product surface.  
Optionally, an adjustable flange seal (accessory) can be used for alignment
- A marking is provided on the gland to aid the alignment. This marking must be aligned towards the tank wall as much as possible.

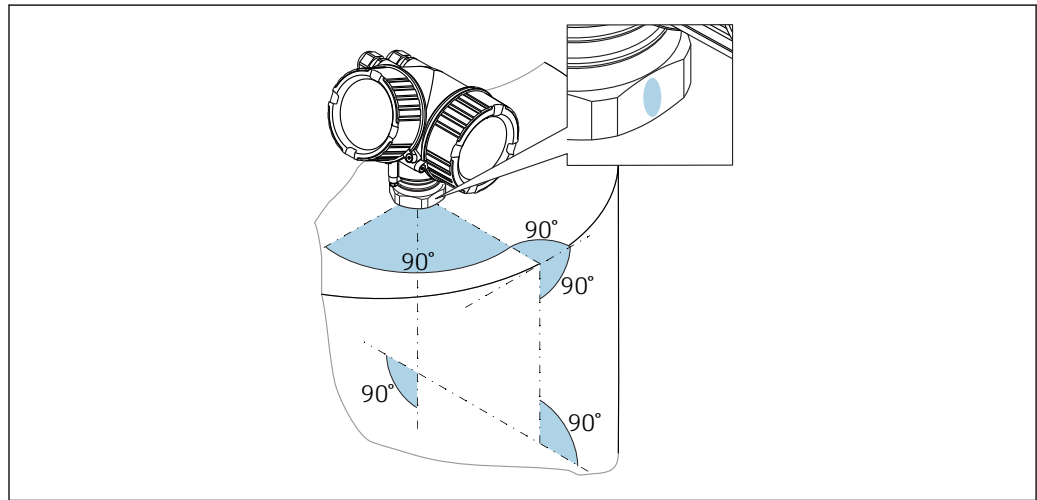

A0019434

 Depending on the device version the marking may be a circle or two parallel lines.

*Information concerning nozzles*

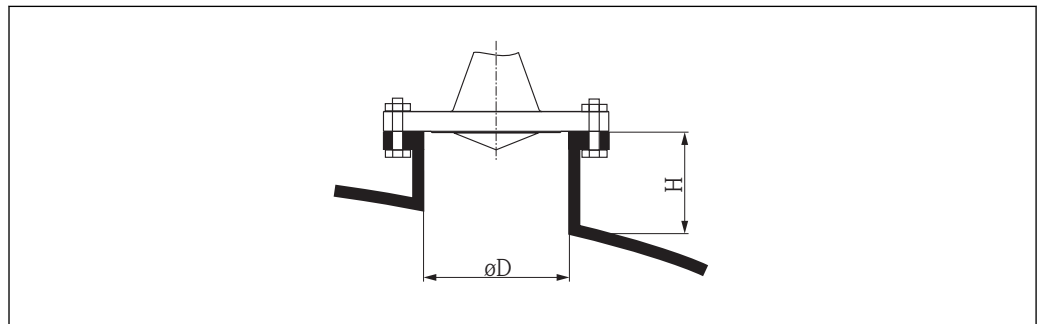

A0016868

 20 Nozzle diameter and height for horn antennas with slip-on flange

$\varnothing D$	Maximum nozzle height $H_{max}$
80 mm (3 in)	300 mm (11.8 in)
100 mm (4 in)	400 mm (15.8 in)
150 mm (6 in)	500 mm (19.7 in)

### Horn antenna with mounting bracket (FMR56)

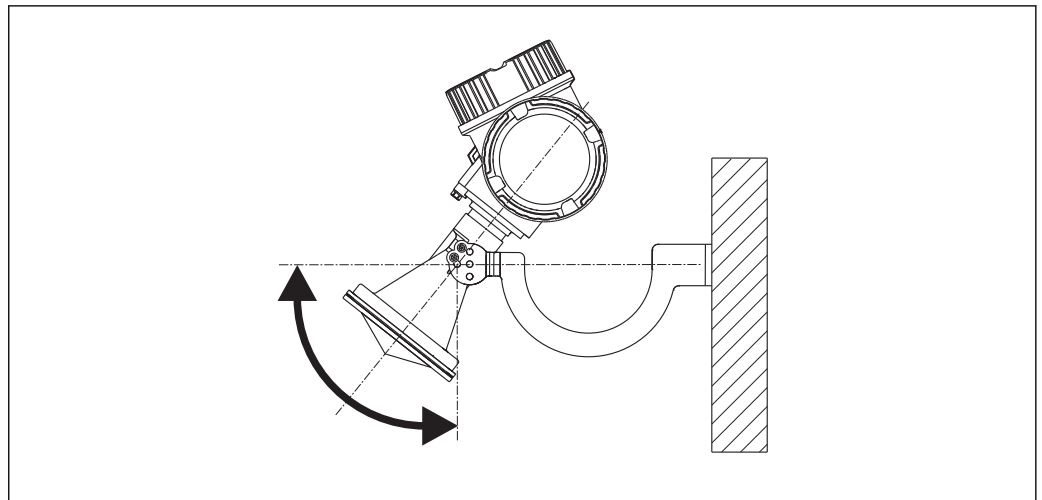

A0016865

21 Mounting the horn antenna with a mounting bracket

Using the mounting bracket, position the antenna so that it is perpendicular to the product surface.

#### NOTICE

**There is no conductive connection between the mounting bracket and transmitter housing.**  
Risk of electrostatic charge.

- ▶ Integrate the mounting bracket in the local potential equalization system.

### Horn antenna (FMR57)

#### Alignment

- Ideally, the horn antenna should be installed vertically. To avoid interference reflections or for optimum alignment in the vessel, the Micropilot can be swiveled by 15° in all directions with the optional alignment device.
- A marking is provided on the gland to aid the alignment. This marking must be aligned towards the tank wall as much as possible.

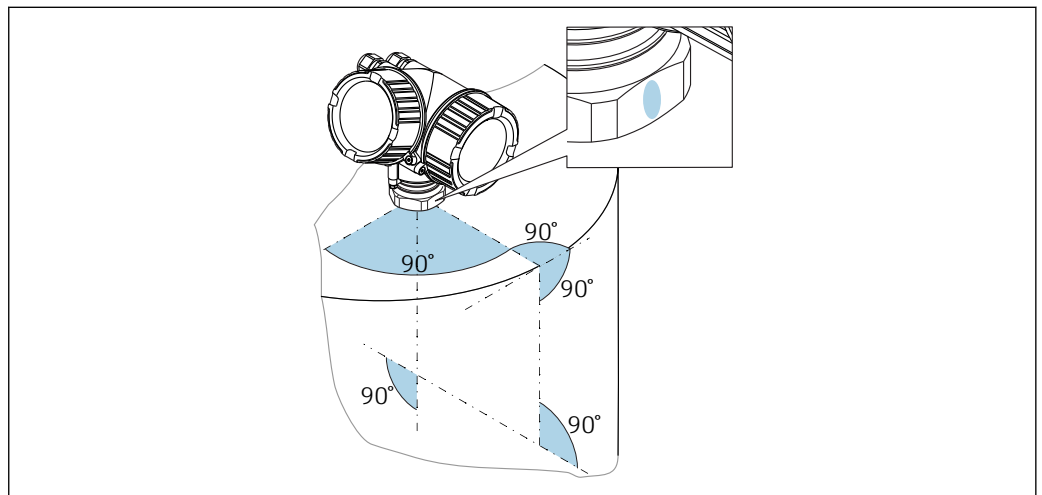

A0019434

-  Depending on the device version the marking may be a circle or two parallel lines.

#### Information concerning nozzles

The horn antenna should project out of the nozzle. If this is not possible for mechanical reasons, larger nozzle heights can be accepted.

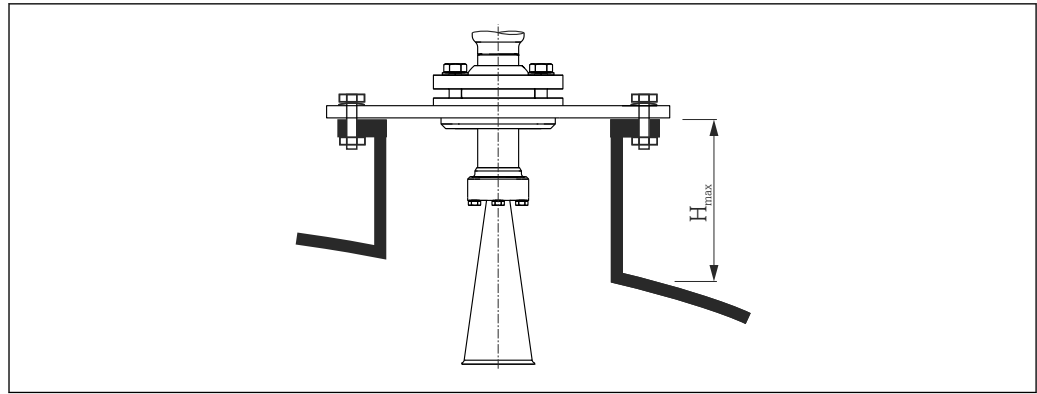

A0016825

22 Nozzle height for horn antenna (FMR57)

Antenna	Maximum nozzle height $H_{max}$ (valid for antennas without an antenna extension)
Horn 80mm/3"	260 mm (10.2 in)
Horn 100mm/4"	480 mm (18.9 in)

**i** Please contact the manufacturer's support service for applications with nozzles that are higher than indicated in the table.

#### Information concerning threaded connections

**i** For devices with a threaded connection, it may be necessary - depending on the antenna size - to first disassemble the horn and then mount it again after screwing in the device.

- When screwing in, turn by the hex bolt only.
- Tool: open-ended wrench 60 mm
- Maximum permissible torque: 60 Nm (44 lbf ft)

#### Parabolic antenna (FMR57)

##### Alignment

Ideally, the parabolic antenna should be installed vertically. To avoid interference reflections or for optimum alignment in the vessel, the Micropilot can be swiveled by 15° in all directions with the optional alignment device.

##### Information concerning nozzles

- Case 1: Ideally, the parabolic antenna should project fully out of the nozzle (1). Particularly when using the alignment device, it is important to ensure that the parabolic reflector is projecting out of the nozzle/ceiling so as not to inhibit alignment.
- Case 2: For applications with higher nozzles, it may be necessary to install the parabolic antenna completely in the nozzle (2).

The maximum height of the nozzle ( $H_{max}$ ) to the parabolic mirror should not exceed 500 mm (19.7 in). Interfering edges within the nozzle should be avoided.



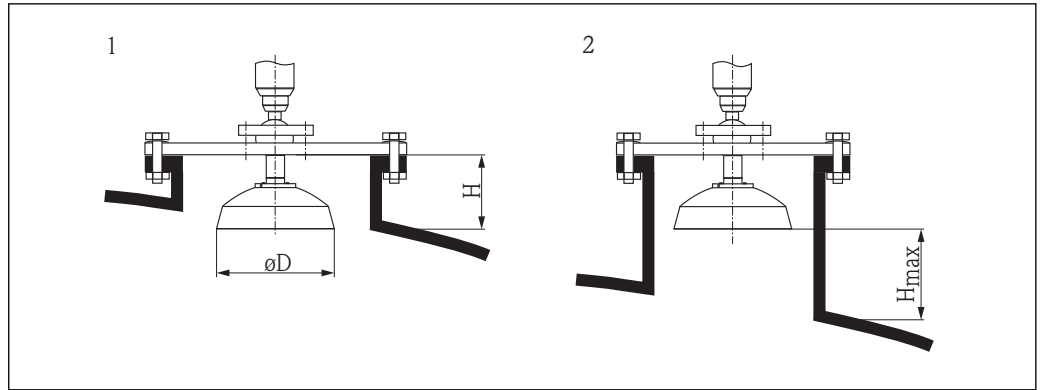

A0016827

23 Nozzle mounting of Micropilot FMR57 with parabolic antenna

- 1 Antenna completely projects out of the nozzle
- 2 Antenna completely inside the nozzle

Antenna	Antenna diameter $D$	Nozzle height $H$ for Case 1	Maximum nozzle height $H_{max}$ for Case 2
Parabolic antenna 200mm/8"	173 mm (6.81 in)	< 50 mm (1.97 in)	500 mm (19.7 in)
Parabolic antenna 250mm/10"	236 mm (9.29 in)	< 50 mm (1.97 in)	500 mm (19.7 in)

Examples for installation with small flange

If the flange is smaller than the parabolic reflector, the device can be mounted in one of the following ways:

- Standard installation, the parabolic reflector must be dismantled in this case
- Installation with hinged flange

Standard installation

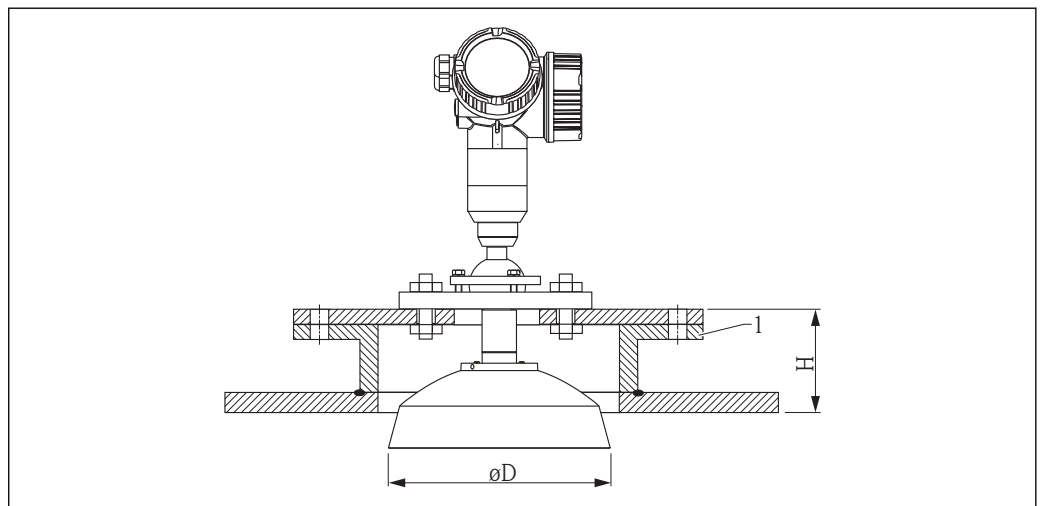

A0018874

1 Nozzle

Antenna size	$\varnothing D$	H (without antenna extension)
200 mm (8 in)	173 mm (6.81 in)	< 50 mm (1.96 in)
250 mm (10 in)	236 mm (9.29 in)	< 50 mm (1.96 in)

*Installation with hinged flange*

 The length of the antenna must be taken into account in the case of hinged flanges.

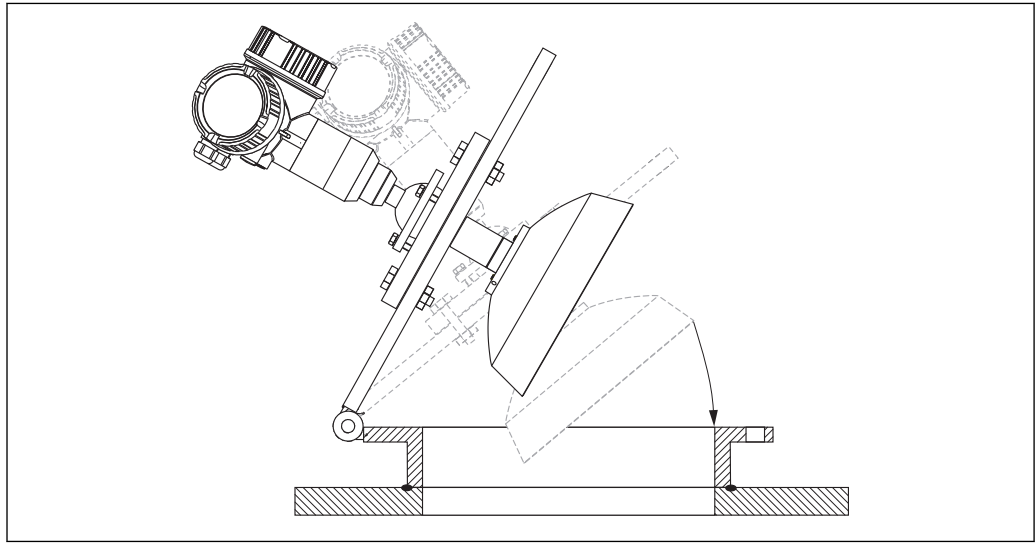

A0018878

*Dismantling the parabolic reflector*

The parabolic reflector can be dismantled for installation in a nozzle:

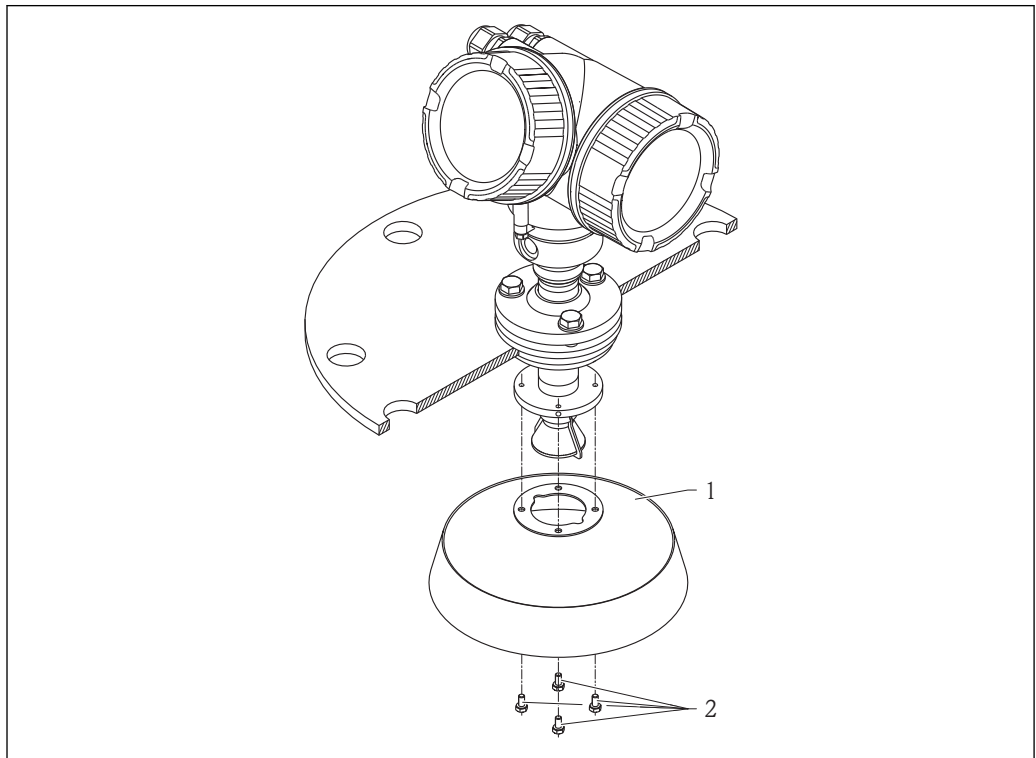

A0018877

- 1 Parabolic reflector
- 2 4 screws; tightening torque: 3 Nm

**Alignment unit for FMR57**

An angle of inclination of up to 15° in all directions can be set for the antenna axis using the alignment unit. The alignment unit is used to optimally align the radar beam to the bulk solid.

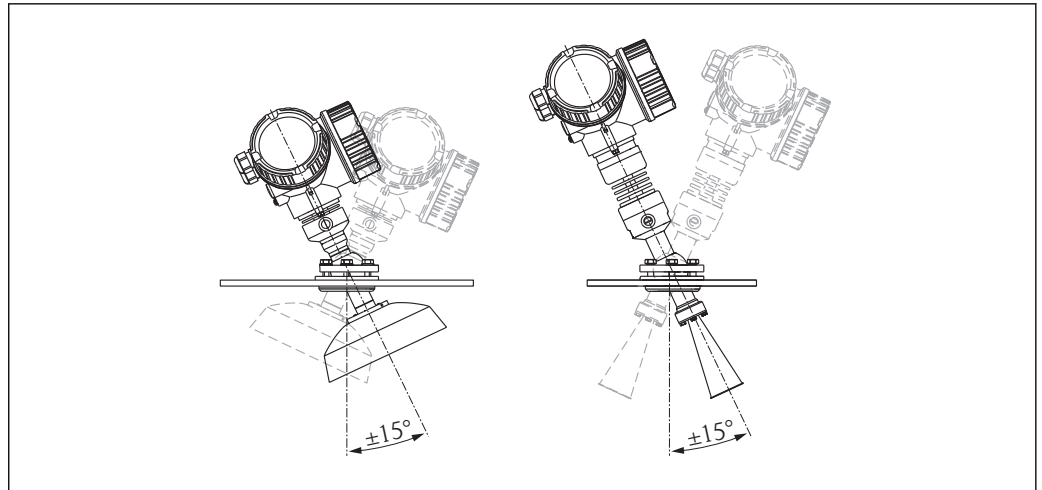

A0016931

24 Micropilot FMR57 with alignment unit

### Integrated purge air connection for FMR57

In applications with strong dust emissions, the integrated purge air connection can prevent the antenna from becoming clogged. Pulse operation is recommended.

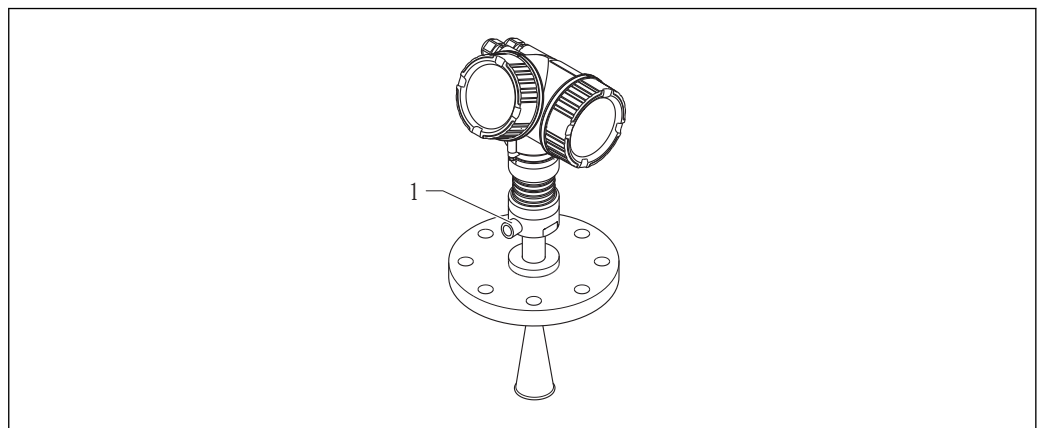

A0016932

25 Micropilot FMR57 with purge air connection

1 Purge air connection NPT $\frac{1}{4}$  or G $\frac{1}{4}$

### Purge air pressure range

- **Pulse operation :**  
max. 6 bar (87 psi)
- **Continuous operation:**  
200 to 500 mbar (3 to 7.25 psi)

- **i** Always use dry purge air
- In general, only purge to the extent necessary as excess purging can cause mechanical damage (abrasion)

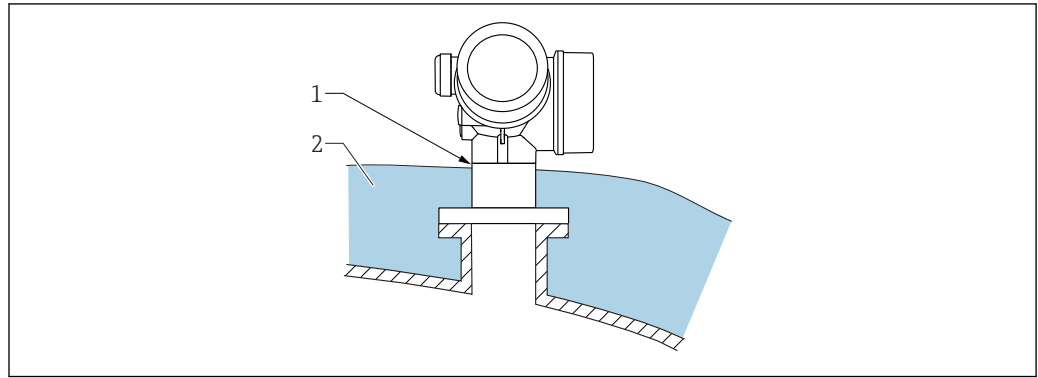
**Container with heat insulation**

A0032207

If process temperatures are high, the device should be included in the usual container insulation system (2) to prevent the electronics from heating as a result of thermal radiation or convection. The insulation should not be higher than the neck of the device (1).

## Environment

<b>Temperature range</b>	<b>Measuring device</b>	-40 to +80 °C (-40 to +176 °F); -50 °C (-58 °F) with manufacturer declaration on request
	<b>Local display</b>	-20 to +70 °C (-4 to +158 °F), the readability of the display may be impaired at temperatures outside the temperature range.
	<b>Remote display FHX50</b>	-40 to 80 °C (-40 to 176 °F)
	<b>Remote display FHX50 (option)</b>	-50 to 80 °C (-58 to 176 °F) <sup>1)</sup>

- 1) This range applies if the option JN "Transmitter ambient temperature -50 °C (-58 °F)" has been selected in order code 580 "Test, certificate. If the temperature is permanently below -40 °C (-40 °F), the chance of failure increases.

For outdoor operation in strong sunlight:

- Mount the device in the shade.
- Avoid direct sunlight, particularly in warm climatic regions.
- Use a weather protection cover (see accessories).

### Temperature limit



The following diagrams only consider functional aspects. Additional restrictions may apply for certified device versions.

In the event of temperature ( $T_p$ ) at the process connection, the permitted ambient temperature ( $T_a$ ) is reduced as indicated in the following diagram (temperature derating) in the table header.

Information on the following derating tables

Feature version	Meaning
A	2-wire; 4-20 mA HART
B	2-wire; 4-20 mA HART, switch output
C	2-wire; 4-20 mA HART, 4-20 mA
E	2-wire; FF, switch output
G	2-wire; PA, switch output
K	4-wire 90-253VAC; 4-20 mA HART
L	4-wire 10, 4-48VDC; 4-20 mA HART

Power supply; output (item 2 in the product structure)	P1		P2		P3		P4		P5		P6	
	$T_p$	$T_a$	$T_p$	$T_a$	$T_p$	$T_a$	$T_p$	$T_a$	$T_p$	$T_a$	$T_p$	$T_a$
	A	-40 (-40)	80 (176)	80 (176)	80 (176)	80 (176)	80 (176)	80 (176)	-40 (-40)	-40 (-40)	-40 (-40)	-
B Switch output not used	-40 (-40)	76 (169)	76 (169)	76 (169)	80 (176)	75 (167)	80 (176)	-40 (-40)	-40 (-40)	-40 (-40)	-	-
B Switch output used	-40 (-40)	60 (140)	60 (140)	60 (140)	80 (176)	58 (136)	80 (176)	-40 (-40)	-40 (-40)	-40 (-40)	-	-
C Channel 2 not used	-40 (-40)	80 (176)	80 (176)	80 (176)	80 (176)	80 (176)	80 (176)	-40 (-40)	-40 (-40)	-40 (-40)	-	-
C Channel 2 used	-40 (-40)	74 (165)	74 (165)	74 (165)	80 (176)	73 (163)	80 (176)	-40 (-40)	-40 (-40)	-40 (-40)	-	-

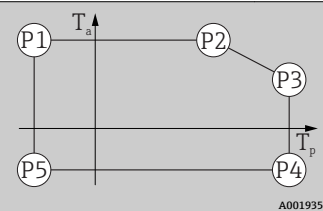

**FMR56**  
**GT19 housing (plastic PBT)**  
**Temperature specifications: °C (°F)**

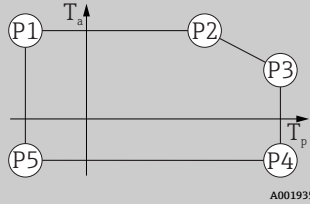

Power supply; output (item 2 in the product structure)	P1		P2		P3		P4		P5		P6	
	T <sub>p</sub>	T <sub>a</sub>	T <sub>p</sub>	T <sub>a</sub>	T <sub>p</sub>	T <sub>a</sub>	T <sub>p</sub>	T <sub>a</sub>	T <sub>p</sub>	T <sub>a</sub>	T <sub>p</sub>	T <sub>a</sub>
E, G Switch output not used	-40 (-40)	79 (174)	79 (174)	79 (174)	80 (176)	79 (174)	80 (176)	-40 (-40)	-40 (-40)	-40 (-40)	-	-
E, G Switch output used	-40 (-40)	63 (145)	63 (145)	63 (145)	80 (176)	60 (140)	80 (176)	-40 (-40)	-40 (-40)	-40 (-40)	-	-

**FMR56**  
**Housing GT20 (aluminum coated)**  
**Temperature specifications: °C (°F)**

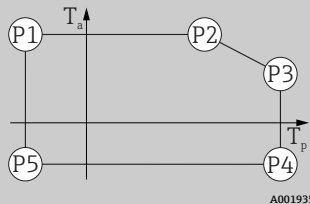

Power supply; output (item 2 in the product structure)	P1		P2		P3		P4		P5		P6	
	T <sub>p</sub>	T <sub>a</sub>	T <sub>p</sub>	T <sub>a</sub>	T <sub>p</sub>	T <sub>a</sub>	T <sub>p</sub>	T <sub>a</sub>	T <sub>p</sub>	T <sub>a</sub>	T <sub>p</sub>	T <sub>a</sub>
A	-40 (-40)	80 (176)	80 (176)	80 (176)	80 (176)	80 (176)	80 (176)	-40 (-40)	-40 (-40)	-40 (-40)	-	-
B Switch output not used	-40 (-40)	80 (176)	80 (176)	80 (176)	80 (176)	80 (176)	80 (176)	-40 (-40)	-40 (-40)	-40 (-40)	-	-
B Switch output used	-40 (-40)	77 (171)	77 (171)	77 (171)	80 (176)	76 (169)	80 (176)	-40 (-40)	-40 (-40)	-40 (-40)	-	-
C Channel 2 not used	-40 (-40)	80 (176)	80 (176)	80 (176)	80 (176)	80 (176)	80 (176)	-40 (-40)	-40 (-40)	-40 (-40)	-	-
C Channel 2 used	-40 (-40)	79 (174)	79 (174)	79 (174)	80 (176)	79 (174)	80 (176)	-40 (-40)	-40 (-40)	-40 (-40)	-	-
E, G Switch output not used	-40 (-40)	80 (176)	80 (176)	80 (176)	80 (176)	80 (176)	80 (176)	-40 (-40)	-40 (-40)	-40 (-40)	-	-
E, G Switch output used	-40 (-40)	78 (172)	78 (172)	78 (172)	80 (176)	78 (172)	80 (176)	-40 (-40)	-40 (-40)	-40 (-40)	-	-
K, L	-40 (-40)	77 (171)	77 (171)	77 (171)	80 (176)	77 (171)	80 (176)	-40 (-40)	-40 (-40)	-40 (-40)	-	-

**FMR57**  
**Seal: Viton GLT**  
**Housing GT18 (316 L)**  
**Temperature specifications: °C (°F)**

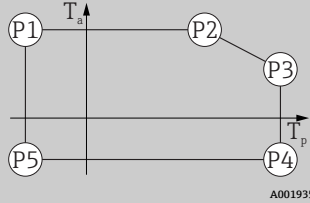

Power supply; output (item 2 in the product structure)	P1		P2		P3		P4		P5		P6	
	T <sub>p</sub>	T <sub>a</sub>	T <sub>p</sub>	T <sub>a</sub>	T <sub>p</sub>	T <sub>a</sub>	T <sub>p</sub>	T <sub>a</sub>	T <sub>p</sub>	T <sub>a</sub>	T <sub>p</sub>	T <sub>a</sub>
A	-40 (-40)	81 (178)	81 (178)	81 (178)	200 (392)	67 (153)	200 (392)	-40 (-40)	-40 (-40)	-40 (-40)	-	-
B Switch output not used	-40 (-40)	82 (180)	82 (180)	82 (180)	200 (392)	67 (153)	200 (392)	-40 (-40)	-40 (-40)	-40 (-40)	-	-

**FMR57**  
 Seal: Viton GLT  
 Housing GT18 (316 L)  
 Temperature specifications: °C (°F)

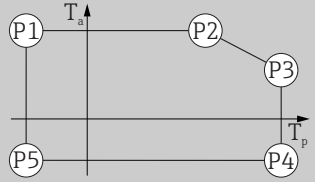

A0019351

Power supply; output (item 2 in the product structure)	P1		P2		P3		P4		P5		P6	
	T <sub>p</sub>	T <sub>a</sub>	T <sub>p</sub>	T <sub>a</sub>	T <sub>p</sub>	T <sub>a</sub>	T <sub>p</sub>	T <sub>a</sub>	T <sub>p</sub>	T <sub>a</sub>	T <sub>p</sub>	T <sub>a</sub>
B Switch output used	-40 (-40)	77 (171)	77 (171)	77 (171)	200 (392)	62 (144)	200 (392)	-40 (-40)	-40 (-40)	-40 (-40)	-	-
C Channel 2 not used	-40 (-40)	82 (180)	82 (180)	82 (180)	200 (392)	68 (154)	200 (392)	-40 (-40)	-40 (-40)	-40 (-40)	-	-
C Channel 2 used	-40 (-40)	79 (174)	79 (174)	79 (174)	200 (392)	64 (147)	200 (392)	-40 (-40)	-40 (-40)	-40 (-40)	-	-
E, G Switch output not used	-40 (-40)	83 (181)	83 (181)	83 (181)	200 (392)	68 (154)	200 (392)	-40 (-40)	-40 (-40)	-40 (-40)	-	-
E, G Switch output used	-40 (-40)	78 (172)	78 (172)	78 (172)	200 (392)	63 (145)	200 (392)	-40 (-40)	-40 (-40)	-40 (-40)	-	-
K, L	-40 (-40)	77 (171)	77 (171)	77 (171)	200 (392)	62 (144)	200 (392)	-40 (-40)	-40 (-40)	-40 (-40)	-	-

**FMR57**  
 Seal: Viton GLT  
 GT19 housing (plastic PBT)  
 Temperature specifications: °C (°F)

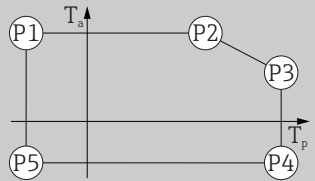

A0019351

Power supply; output (item 2 in the product structure)	P1		P2		P3		P4		P5		P6	
	T <sub>p</sub>	T <sub>a</sub>	T <sub>p</sub>	T <sub>a</sub>	T <sub>p</sub>	T <sub>a</sub>	T <sub>p</sub>	T <sub>a</sub>	T <sub>p</sub>	T <sub>a</sub>	T <sub>p</sub>	T <sub>a</sub>
A	-40 (-40)	80 (176)	80 (176)	80 (176)	200 (392)	53 (127)	200 (392)	-40 (-40)	-40 (-40)	-40 (-40)	-	-
B Switch output not used	-40 (-40)	76 (169)	76 (169)	76 (169)	200 (392)	53 (127)	200 (392)	-40 (-40)	-40 (-40)	-40 (-40)	-	-
B Switch output used	-40 (-40)	60 (140)	60 (140)	60 (140)	200 (392)	37 (99)	200 (392)	-40 (-40)	-40 (-40)	-40 (-40)	-	-
C Channel 2 not used	-40 (-40)	82 (180)	82 (180)	82 (180)	200 (392)	53 (127)	200 (392)	-40 (-40)	-40 (-40)	-40 (-40)	-	-
C Channel 2 used	-40 (-40)	74 (165)	74 (165)	74 (165)	200 (392)	53 (127)	200 (392)	-40 (-40)	-40 (-40)	-40 (-40)	-	-
E, G Switch output not used	-40 (-40)	79 (174)	79 (174)	79 (174)	200 (392)	53 (127)	200 (392)	-40 (-40)	-40 (-40)	-40 (-40)	-	-
E, G Switch output used	-40 (-40)	63 (145)	63 (145)	63 (145)	200 (392)	40 (104)	200 (392)	-40 (-40)	-40 (-40)	-40 (-40)	-	-

**FMR57**  
**Seal: Viton GLT**  
**Housing GT20 (aluminum coated)**  
**Temperature specifications: °C (°F)**

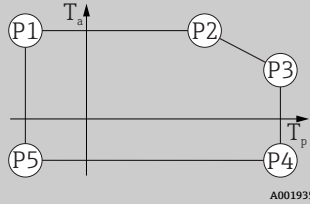

A0019351

Power supply; output (item 2 in the product structure)	P1		P2		P3		P4		P5		P6	
	T <sub>p</sub>	T <sub>a</sub>	T <sub>p</sub>	T <sub>a</sub>	T <sub>p</sub>	T <sub>a</sub>	T <sub>p</sub>	T <sub>a</sub>	T <sub>p</sub>	T <sub>a</sub>	T <sub>p</sub>	T <sub>a</sub>
A	-40 (-40)	81 (178)	81 (178)	81 (178)	200 (392)	70 (158)	200 (392)	-40 (-40)	-40 (-40)	-40 (-40)	-	-
B Switch output not used	-40 (-40)	82 (180)	82 (180)	82 (180)	200 (392)	70 (158)	200 (392)	-40 (-40)	-40 (-40)	-40 (-40)	-	-
B Switch output used	-40 (-40)	77 (171)	77 (171)	77 (171)	200 (392)	65 (149)	200 (392)	-40 (-40)	-40 (-40)	-40 (-40)	-	-
C Channel 2 not used	-40 (-40)	82 (180)	82 (180)	82 (180)	200 (392)	71 (160)	200 (392)	-40 (-40)	-40 (-40)	-40 (-40)	-	-
C Channel 2 used	-40 (-40)	79 (174)	79 (174)	79 (174)	200 (392)	67 (153)	200 (392)	-40 (-40)	-40 (-40)	-40 (-40)	-	-
E, G Switch output not used	-40 (-40)	83 (181)	83 (181)	83 (181)	200 (392)	71 (160)	200 (392)	-40 (-40)	-40 (-40)	-40 (-40)	-	-
E, G Switch output used)	-40 (-40)	78 (172)	78 (172)	78 (172)	200 (392)	66 (151)	200 (392)	-40 (-40)	-40 (-40)	-40 (-40)	-	-
K, L	-40 (-40)	77 (171)	77 (171)	77 (171)	200 (392)	66 (151)	200 (392)	-40 (-40)	-40 (-40)	-40 (-40)	-	-

**FMR57**  
**Seal: graphite**  
**Housing GT18 (316 L)**  
**Temperature specifications: °C (°F)**

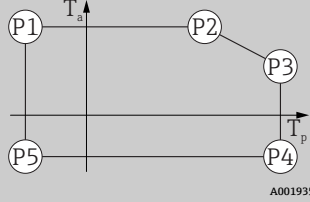

A0019351

Power supply; output (item 2 in the product structure)	P1		P2		P3		P4		P5		P6	
	T <sub>p</sub>	T <sub>a</sub>	T <sub>p</sub>	T <sub>a</sub>	T <sub>p</sub>	T <sub>a</sub>	T <sub>p</sub>	T <sub>a</sub>	T <sub>p</sub>	T <sub>a</sub>	T <sub>p</sub>	T <sub>a</sub>
A	-40 (-40)	81 (178)	81 (178)	81 (178)	400 (752)	51 (124)	400 (752)	-40 (-40)	-40 (-40)	-40 (-40)	-	-
B Switch output not used	-40 (-40)	82 (180)	82 (180)	82 (180)	400 (752)	51 (124)	400 (752)	-40 (-40)	-40 (-40)	-40 (-40)	-	-
B Switch output used	-40 (-40)	77 (171)	77 (171)	77 (171)	400 (752)	47 (117)	400 (752)	-40 (-40)	-40 (-40)	-40 (-40)	-	-
C Channel 2 not used	-40 (-40)	82 (180)	82 (180)	82 (180)	400 (752)	51 (124)	400 (752)	-40 (-40)	-40 (-40)	-40 (-40)	-	-
C Channel 2 used	-40 (-40)	79 (174)	79 (174)	79 (174)	400 (752)	49 (120)	400 (752)	-40 (-40)	-40 (-40)	-40 (-40)	-	-
E, G Switch output not used	-40 (-40)	83 (181)	83 (181)	83 (181)	400 (752)	51 (124)	400 (752)	-40 (-40)	-40 (-40)	-40 (-40)	-	-
E, G Switch output used	-40 (-40)	78 (172)	78 (172)	78 (172)	400 (752)	49 (120)	400 (752)	-40 (-40)	-40 (-40)	-40 (-40)	-	-
K, L	-40 (-40)	77 (171)	77 (171)	77 (171)	400 (752)	48 (118)	400 (752)	-40 (-40)	-40 (-40)	-40 (-40)	-	-



<b>FMR57</b> Seal: graphite GT19 housing (plastic PBT) Temperature specifications: °C (°F)												
<small>A0019351</small>												
Power supply; output (item 2 in the product structure)	P1		P2		P3		P4		P5		P6	
	T <sub>p</sub>	T <sub>a</sub>	T <sub>p</sub>	T <sub>a</sub>	T <sub>p</sub>	T <sub>a</sub>	T <sub>p</sub>	T <sub>a</sub>	T <sub>p</sub>	T <sub>a</sub>	T <sub>p</sub>	T <sub>a</sub>
A	-40 (-40)	80 (176)	80 (176)	80 (176)	400 (752)	15 (59)	400 (752)	-40 (-40)	-40 (-40)	-40 (-40)	-	-
B Switch output not used	-40 (-40)	76 (169)	76 (169)	76 (169)	400 (752)	15 (59)	400 (752)	-40 (-40)	-40 (-40)	-40 (-40)	-	-
B Switch output used	-40 (-40)	60 (140)	60 (140)	60 (140)	400 (752)	15 (59)	400 (752)	-40 (-40)	-40 (-40)	-40 (-40)	-	-
C Channel 2 not used	-40 (-40)	82 (180)	82 (180)	82 (180)	400 (752)	15 (59)	400 (752)	-40 (-40)	-40 (-40)	-40 (-40)	-	-
C Channel 2 used	-40 (-40)	74 (165)	74 (165)	74 (165)	400 (752)	15 (59)	400 (752)	-40 (-40)	-40 (-40)	-40 (-40)	-	-
E, G Switch output not used	-40 (-40)	79 (174)	79 (174)	79 (174)	400 (752)	15 (59)	400 (752)	-40 (-40)	-40 (-40)	-40 (-40)	-	-
E, G Switch output used	-40 (-40)	63 (145)	63 (145)	63 (145)	400 (752)	15 (59)	400 (752)	-40 (-40)	-40 (-40)	-40 (-40)	-	-

<b>FMR57</b> Seal: graphite Housing GT20 (aluminum coated) Temperature specifications: °C (°F)												
<small>A0019351</small>												
Power supply; output (item 2 in the product structure)	P1		P2		P3		P4		P5		P6	
	T <sub>p</sub>	T <sub>a</sub>	T <sub>p</sub>	T <sub>a</sub>	T <sub>p</sub>	T <sub>a</sub>	T <sub>p</sub>	T <sub>a</sub>	T <sub>p</sub>	T <sub>a</sub>	T <sub>p</sub>	T <sub>a</sub>
A	-40 (-40)	81 (178)	81 (178)	81 (178)	400 (752)	58 (136)	400 (752)	-40 (-40)	-40 (-40)	-40 (-40)	-	-
B Switch output not used	-40 (-40)	82 (180)	82 (180)	82 (180)	400 (752)	59 (138)	400 (752)	-40 (-40)	-40 (-40)	-40 (-40)	-	-
B Switch output used	-40 (-40)	77 (171)	77 (171)	77 (171)	400 (752)	53 (127)	400 (752)	-40 (-40)	-40 (-40)	-40 (-40)	-	-
C Channel 2 not used	-40 (-40)	82 (180)	82 (180)	82 (180)	400 (752)	59 (138)	400 (752)	-40 (-40)	-40 (-40)	-40 (-40)	-	-
C Channel 2 used	-40 (-40)	79 (174)	79 (174)	79 (174)	400 (752)	56 (133)	400 (752)	-40 (-40)	-40 (-40)	-40 (-40)	-	-
E, G Switch output not used	-40 (-40)	83 (181)	83 (181)	83 (181)	400 (752)	59 (138)	400 (752)	-40 (-40)	-40 (-40)	-40 (-40)	-	-
E, G Switch output used	-40 (-40)	78 (172)	78 (172)	78 (172)	400 (752)	55 (131)	400 (752)	-40 (-40)	-40 (-40)	-40 (-40)	-	-
K, L	-40 (-40)	77 (171)	77 (171)	77 (171)	400 (752)	54 (129)	400 (752)	-40 (-40)	-40 (-40)	-40 (-40)	-	-

**Storage temperature**                    -40 to +80 °C (-40 to +176 °F)  
    -50 °C (-58 °F) with manufacturer declaration on request

**Climate class**                                DIN EN 60068-2-38 (test Z/AD)

**Altitude according to IEC61010-1 Ed.3**

- Generally up to 2 000 m (6 600 ft) above MSL.
- Above 2 000 m (6 600 ft) if the following conditions are met:
  - Ordering feature O20 "Power supply; Output" = A, B, C, E or G (2-wire versions)
  - Supply voltage  $U < 35\text{ V}$
  - Supply voltage of overvoltage category 1

**Degree of protection**

- When housing is closed, tested according to:
    - IP68, NEMA6P (24 h at 1.83 m under water)
    - For plastic housing with see-through lid (display): IP68 (24 h at 1.00 m under water)  
This restriction applies if the following options have been selected simultaneously in the product structure: O30 ("Display/operation") = C ("SD02") or E ("SD03"); O40 ("Housing") = A ("GT19").
    - IP66, NEMA4X
  - With housing open: IP20, NEMA1
  - Display module: IP22, NEMA2
-  Degree of protection IP68 NEMA6P only applies for M12 PROFIBUS PA plugs if the PROFIBUS cable is plugged in and is also rated IP68 NEMA6P.

**Vibration resistance**

DIN EN 60068-2-64 / IEC 60068-2-64: 20 to 2 000 Hz, 1 (m/s<sup>2</sup>)<sup>2</sup>/Hz

**Cleaning the antenna**

The antenna may become contaminated depending on the application. Emission and reception of microwaves can thus be hindered. The level of contamination leading to this error depends on the medium and on the reflectivity, which is mainly determined by the dielectric constant  $\epsilon_r$ .

If the medium tends to cause contamination and buildup, cleaning on a regular basis is recommended, e.g. using a purge air connection in the case of FMR57. Care must be taken to ensure the antenna is not damaged in the process of mechanical or hose-down cleaning. Material compatibility must be taken into account if cleaning agents are used! The maximum permissible flange temperatures should not be exceeded.

**Electromagnetic compatibility (EMC)**

Electromagnetic compatibility in accordance with all of the relevant requirements outlined in the EN 61326 series and NAMUR Recommendation EMC (NE 21). For details, refer to the Declaration of Conformity.

 Download at [www.endress.com](http://www.endress.com)

A normal device cable suffices if only the analog signal should be used. Use a shielded cable for digital communication (HART/ PA/ FF).

Always use a shielded cable for the electronic version "2-wire, 4-20 mA HART + 4-20 mA analog".

Maximum measured error during EMC testing: < 0.5 % of the span. By way of derogation, for devices with a plastic housing and see-through lid (integrated display SD02 or SD03) the measured error can be up to 2 % of the span in the event of strong electromagnetic radiation in the 1 to 2 GHz frequency range.

## Process

### Process temperature, process pressure



The pressure ranges indicated can be reduced by the choice of process connection. The nominal pressure (PN) indicated on the nameplate refers to a reference temperature of 20 °C, and of 100 °F for ASME flanges. Observe pressure-temperature dependency.

Please refer to the following standards for the pressure values permitted at higher temperatures:

- EN 1092-1: 2001 Tab. 18

With regard to their stability-temperature property, the materials 1.4435 and 1.4404 are grouped together under 13EO in EN 1092-1 Tab. 18. The chemical composition of the two materials can be identical.

- ASME B 16.5a – 1998 Tab. 2-2.2 F316
- ASME B 16.5a – 1998 Tab. 2.3.8 N10276
- JIS B 2220

### FMR56

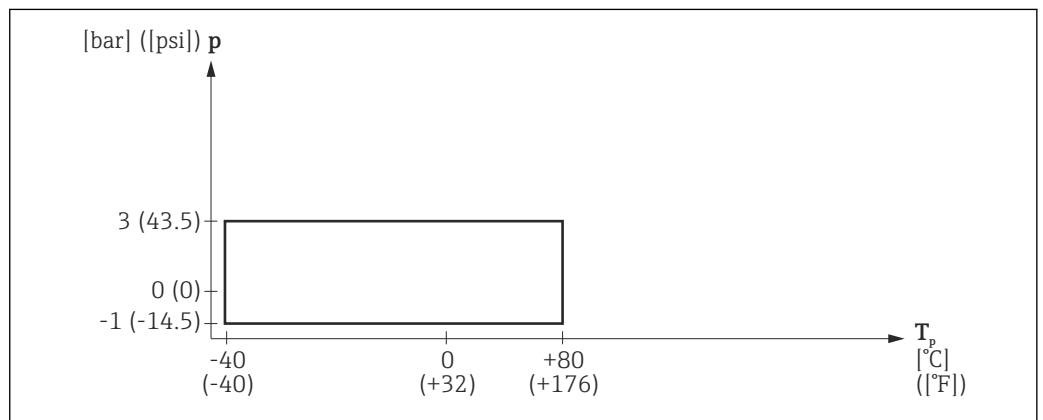

A0023253-EN

26 FMR56: Permitted range for process temperature and process pressure

Device version	Process temperature range	Process pressure range
For all versions	-40 to +80 °C (-40 to +176 °F)	$p_{rel} = -1$ to 3 bar (-14.5 to 43.5 psi) $p_{abs} < 4$ bar (58 psi) <sup>1)</sup>

1) The pressure range may be reduced further if the device has a CRN approval → 81

### FMR57

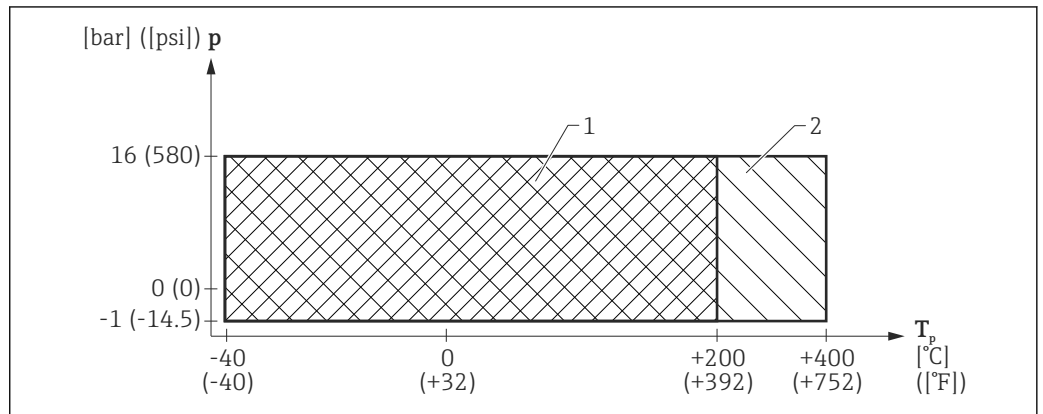

A0023253-EN

27 FMR57: Permitted range for process temperature and process pressure

- Seal: Viton GLT (feature 090 "Seal", version A6)
- Seal: graphite (feature 090 "Seal", version D4)

---

Feature 090 "Seal"	Process temperature range	Process pressure range
A6: Viton GLT	-40 to +200 °C (-40 to +392 °F)	p <sub>rel</sub> = -1 to 16 bar (-14.5 to 232 psi)
D4: graphite	-40 to +400 °C (-40 to +752 °F)	

## Mechanical construction

### Dimensions

#### Dimensions of the electronics housing

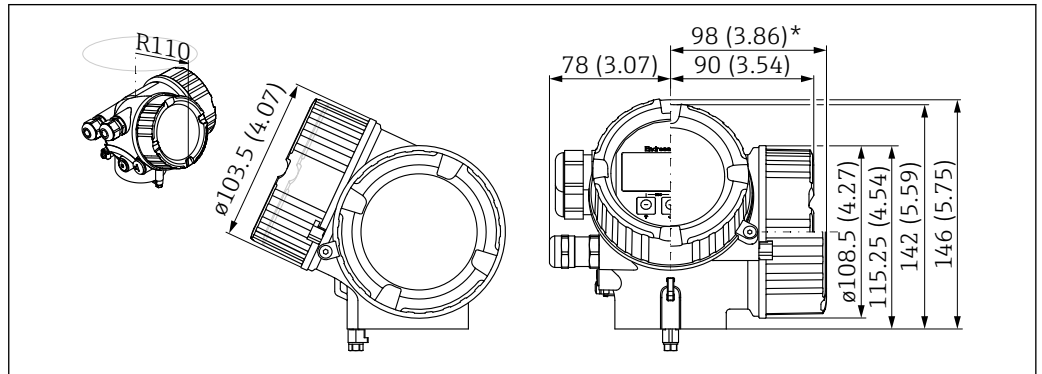

A0011666

28 Housing GT18 (316L). Unit of measurement mm (in)

\*For devices with integrated overvoltage protection.

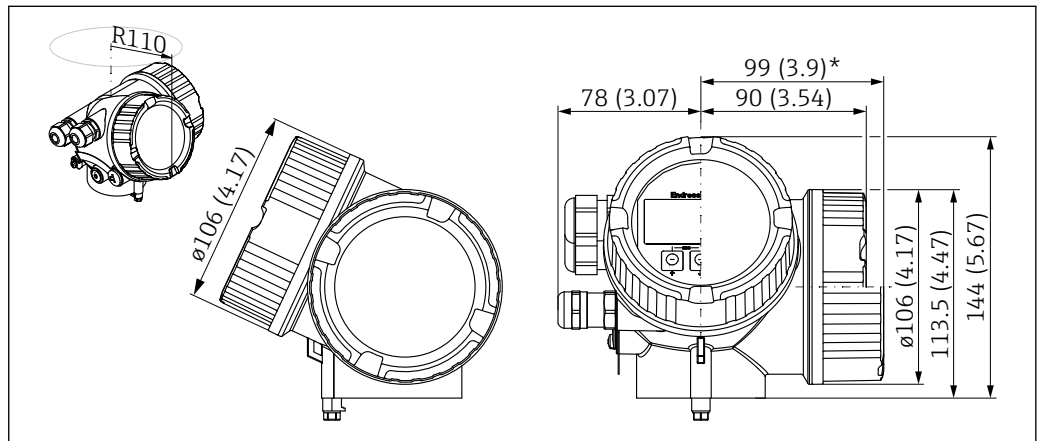

A0011346

29 GT19 housing (plastic PBT). Unit of measurement mm (in)

\*For devices with integrated overvoltage protection.

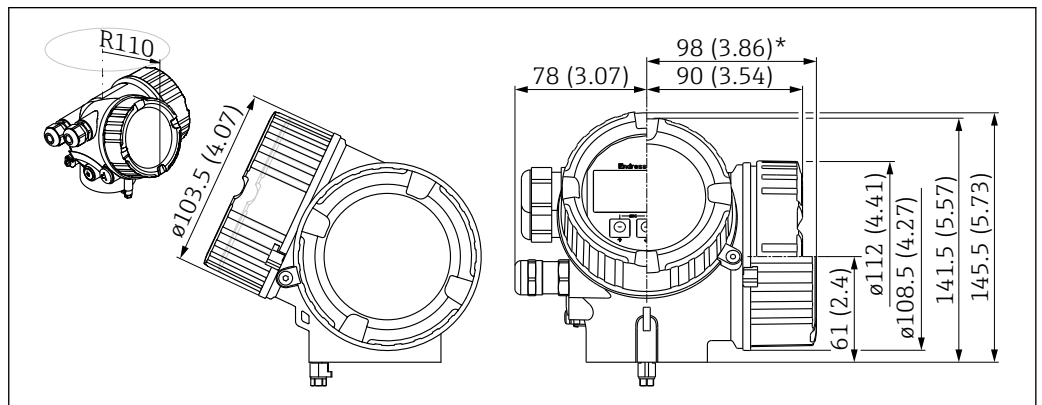

A0020751

30 Housing GT20 (aluminum coated). Unit of measurement mm (in)

\*For devices with integrated overvoltage protection.

FMR56 with mounting bracket or onsite mounting device

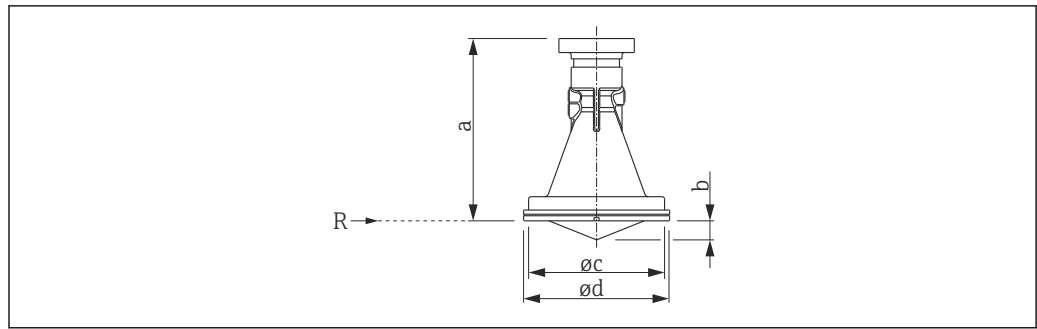

A0017747

31 Dimensions of FMR56 without process connection. Unit of measurement mm (in)

R Reference point of measurement

Antenna	a	b	Øc	Ød
Horn 80mm/3"	137.9 mm (5.43 in)	15 mm (0.59 in)	107 mm (4.21 in)	115 mm (4.53 in)
Horn 100mm/4"	150.5 mm (5.93 in)	20 mm (0.79 in)	127 mm (5 in)	135 mm (5.31 in)

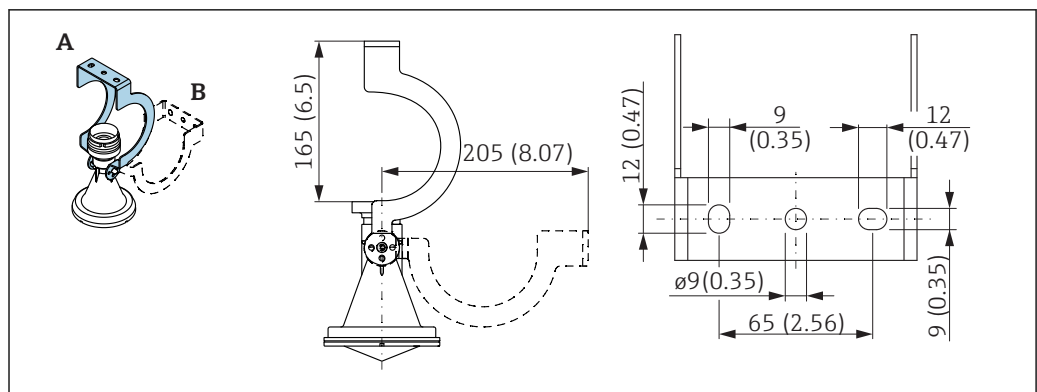

A0017746

32 Dimensions of mounting bracket. Unit of measurement mm (in)

A Mounting bracket oriented for ceiling mounting

B Mounting bracket oriented for wall mounting

**FMR56 with slip-on flange 3"/DN80**

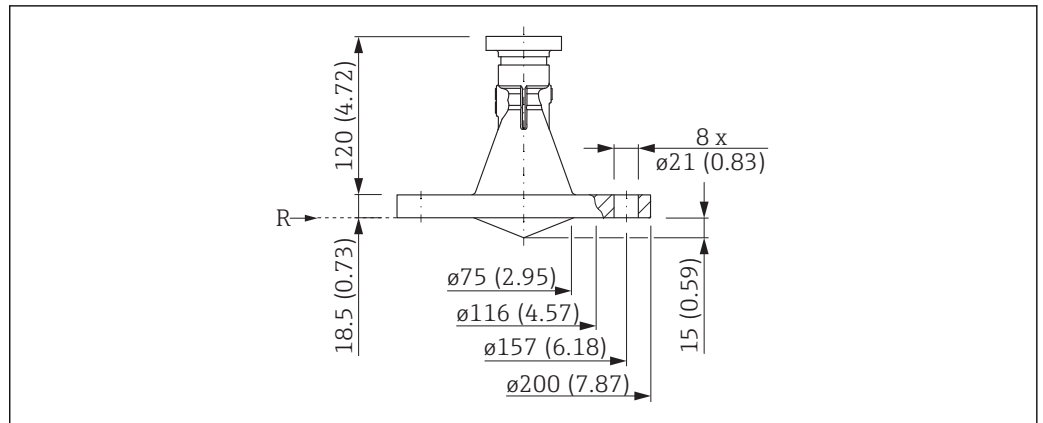

A0023377

33 Dimensions of FMR56 with slip-on flange 3"/DN80. Unit of measurement mm (in)

R Reference point of measurement

**Applies to the following device versions**

- **Feature 100 "Process connection"**  
XWG: UNI slip-on flange 3"/DN80, PP
- **Feature 070 "Antenna"**  
BN: horn 80mm/3", PP clad



The UNI slip-on flange suits:

- ASME: NPS 3" Cl.150
- EN: DN80 PN16
- JIS: 10K 80

## FMR56 with slip-on flange 4"/DN100

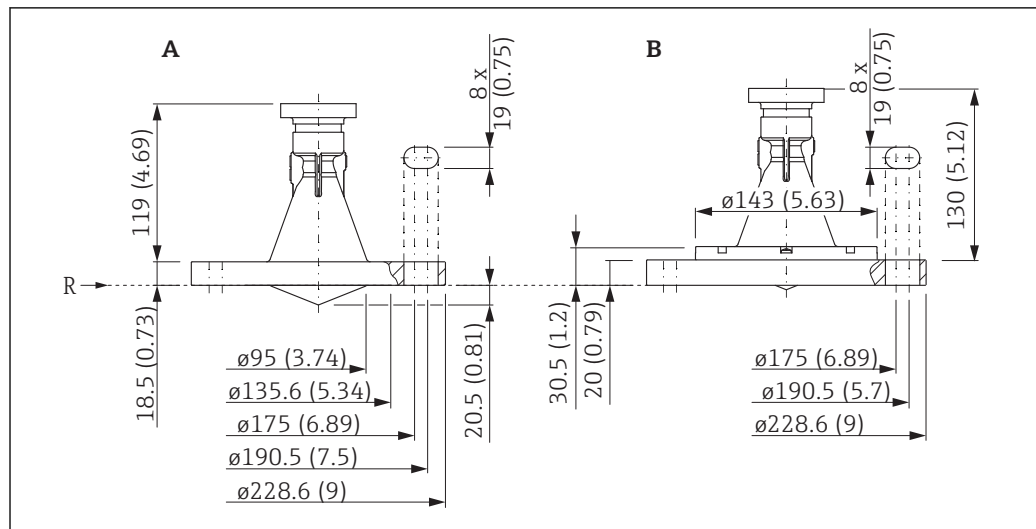

A0023379

34 Dimensions of FMR56 with slip-on flange 4"/DN100. Unit of measurement mm (in)

A Horn antenna 100mm/4" (without adapter ring)

B Horn antenna 80mm/3" (with adapter ring)

R Reference point of measurement

#### Applies to the following device versions

- **Feature 100 "Process connection":**

XZG: UNI slip-on flange 4"/DN100

- **Feature 070 "Antenna":**

- BR: horn 100mm/4", PP clad (A)

- BN: horn 80mm/3", PP clad (B)



The UNI slip-on flange suits:

- ASME: NPS 4" Cl.150

- EN: DN100 PN16

- JIS: 10K 100



FMR56 with slip-on flange 6"/DN150

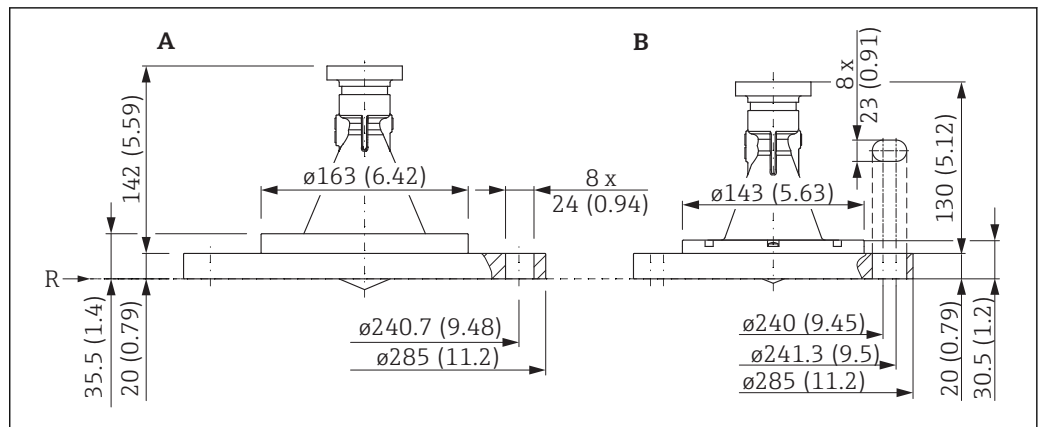

A0023380

35 Dimensions of FMR56 with slip-on flange 6"/DN150. Unit of measurement mm (in)

A Horn antenna 100mm/4"

B Horn antenna 80mm/3"

R Reference point of measurement

Applies to the following device versions

- **Feature 100 "Process connection":**  
XOG: UNI slip-on flange 6"/DN150, PP
- **Feature 070 "Antenna":**
  - BR: horn 100mm/4", PP cladded (A)
  - BN: horn 80mm/3", PP cladded (B)



The UNI slip-on flange suits:

- ASME: NPS 6" Cl.150
- EN: DN150 PN16
- JIS: 10K 150

FMR57 with horn antenna - standard version

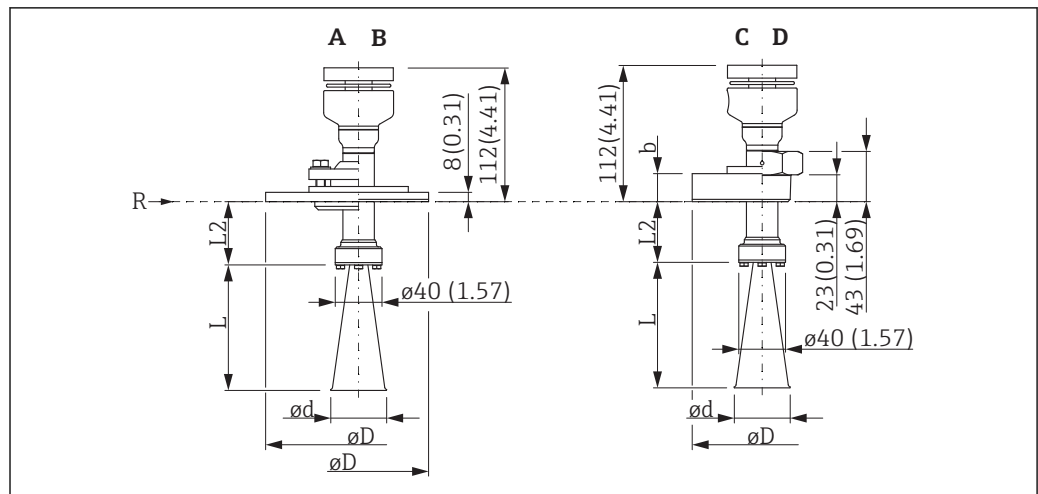

A0023392

36 Dimensions of FMR57 with horn antenna - standard version. Unit of measurement mm (in)

- A Process connection: alignment unit with UNI flange
- B Process connection: UNI flange
- C Process connection: flange
- D Process connection: thread MNPT1-1/2 or R1-1/2
- R Reference point of measurement
- ØD As per flange standard ASME B16.5 / EN1092-1 / JIS B2220
- b As per flange standard ASME B16.5 / EN1092-1 / JIS B2220

Applies to the following device versions

- Feature 070 "Antenna"
  - BC: horn 80mm/3"
  - BD: horn 100mm/4"
- Feature 090 "Seal"
  - A6: Viton GLT, -40 to 200°C/-40 to 392°F

Dimensions of the antenna

Antenna	Horn 80mm/3"	Horn 100mm/4"
L	211 mm (8.37 in)	430 mm (16.9 in)
Ød	75 mm (2.95 in)	95 mm (3.74 in)
L2	50 mm (1.97 in)	50 mm (1.97 in)
	For version with 250 mm (10 in) antenna extension (accessory):	
	300 mm (11.8 in)	300 mm (11.8 in)
L2	For version with 450 mm (18 in) antenna extension (accessory):	
	500 mm (19.7 in)	500 mm (19.7 in)

FMR57 with horn antenna - high-temperature version

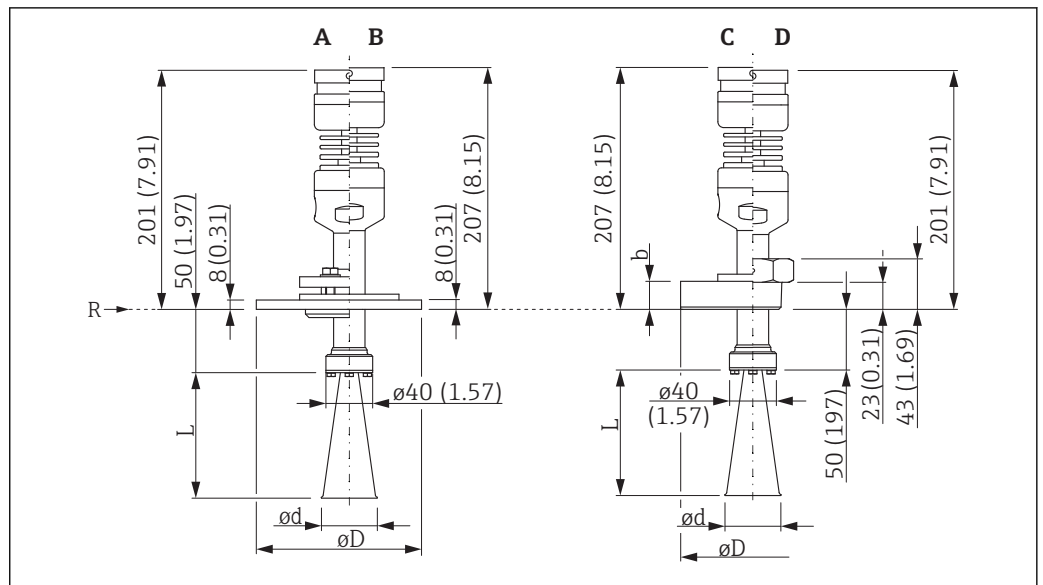

A0023394

37 Dimensions of FMR57 with horn antenna - high-temperature version; engineering unit: mm(in)

A Process connection: alignment unit with UNI flange

B Process connection: UNI flange

C Process connection: flange

D Process connection: thread MNPT1-1/2 or R1-1/2

R Reference point of measurement

$\varnothing D$  As per flange standard ASME B16.5 / EN1092-1 / JIS B2220

b As per flange standard ASME B16.5 / EN1092-1 / JIS B2220

Applies to the following device versions

■ Feature 070 "Antenna"

- BC: horn 80mm/3"
- BD: horn 100mm/4"

■ Feature 090 "Seal"

D4: graphite, -40 to 400°C/-40 to 752°F

Antenna	L	$\varnothing d$
Horn 80mm/3"	211 mm (8.37 in)	75 mm (2.95 in)
Horn 100mm/4"	430 mm (16.9 in)	95 mm (3.74 in)

## FMR57 with parabolic antenna

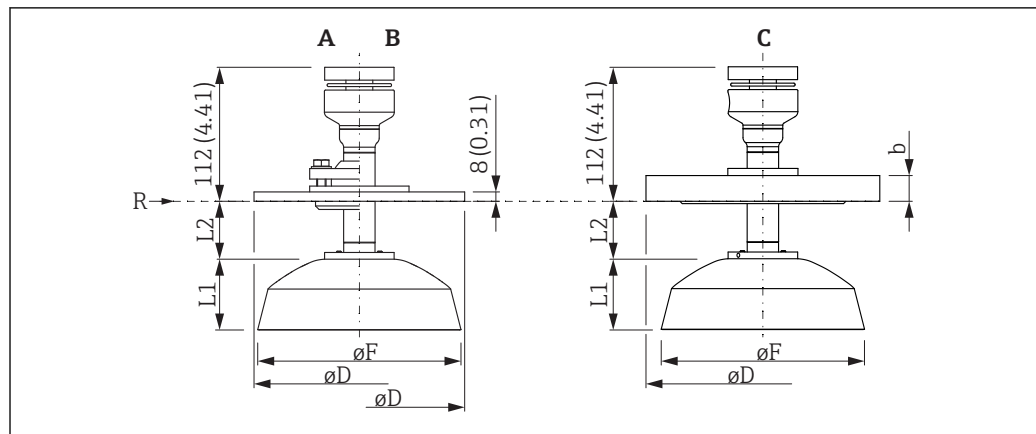

A0023393

38 Dimensions of FMR57 with parabolic antenna, engineering unit: mm (in)

A Process connection: alignment unit with UNI flange

B Process connection: UNI flange

C Process connection: flange

R Reference point of measurement

ØD As per flange standard ASME B16.5 / EN1092-1 / JIS B2220

b As per flange standard ASME B16.5 / EN1092-1 / JIS B2220

Antenna	Parabolic antenna 200 mm/8"	Parabolic antenna 250 mm/10"
L1	61 mm (2.4 in)	89 mm (3.5 in)
ØF	173 mm (6.81 in)	236 mm (9.29 in)
L2	50 mm (1.97 in)	37 mm (1.46 in)
	For version with 250 mm (10 in) antenna extension <sup>1)</sup> :	
	300 mm (11.8 in)	287 mm (11.3 in)
L2	For version with 450 mm (18 in) antenna extension <sup>1)</sup> :	
	500 mm (19.7 in)	487 mm (19.2 in)

1) Product structure: feature 610: "Accessory mounted"

**FMR57: dimensions of flanges**

**Process connection - flange**

Dimensions  $\varnothing D$  and  $b$  as per flange standard:

- EN1092-1 (suitable for DIN2527)
- ASME B16.5
- JIS B2220

UNI flange for FMR57

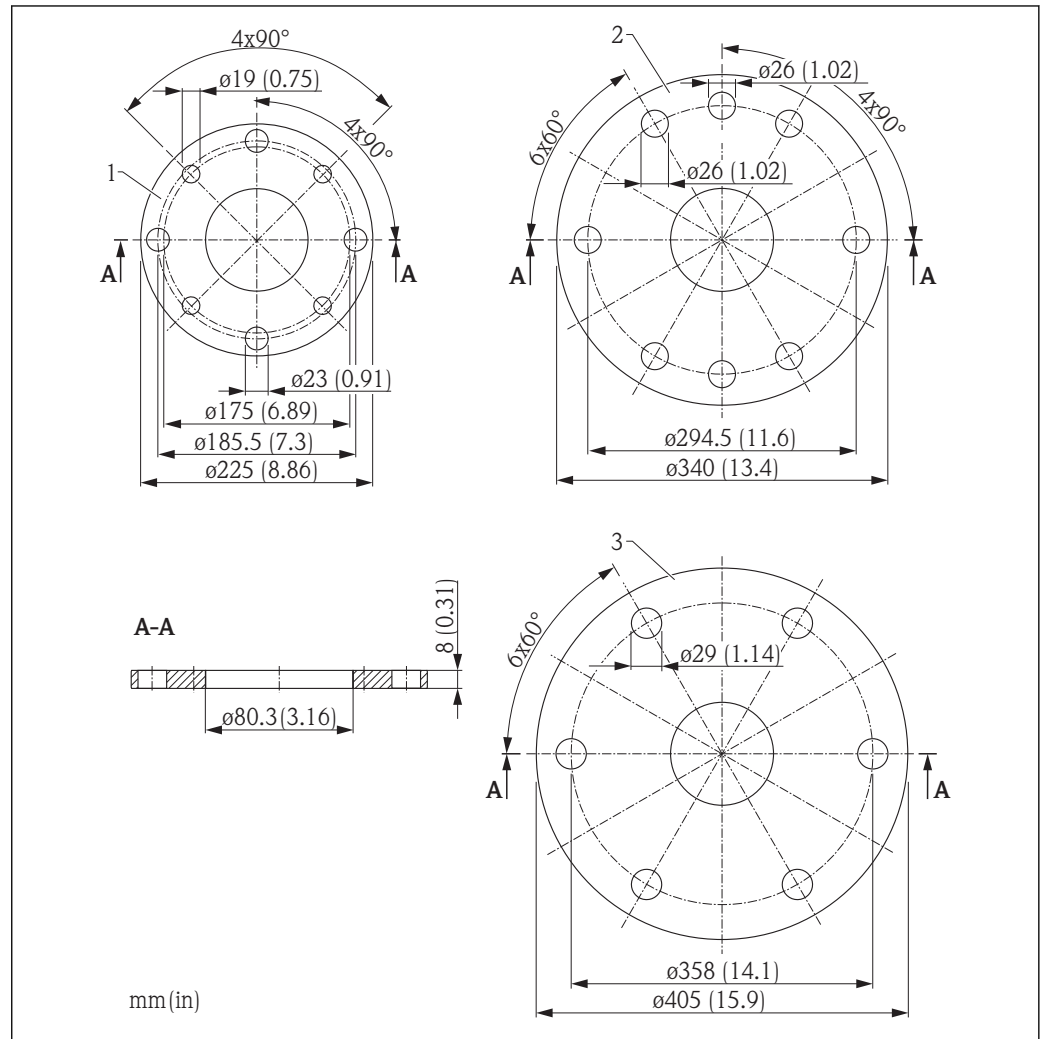

- 1 UNI flange DN100/4"/100A,  $p_{abs} < 2$  bar (29 psi), 316L
- 2 UNI flange DN200/8"/200A,  $p_{abs} < 2$  bar (29 psi), 316L
- 3 UNI flange DN250/10"/250A,  $p_{abs} < 2$  bar (29 psi), 316L

**i** The number of bolts is reduced in some cases. To match different standards the bores are enlarged. Therefore the bolts should be aligned centrally to the counter flange before tightening.

Alignment unit with UNI flange for FMR57

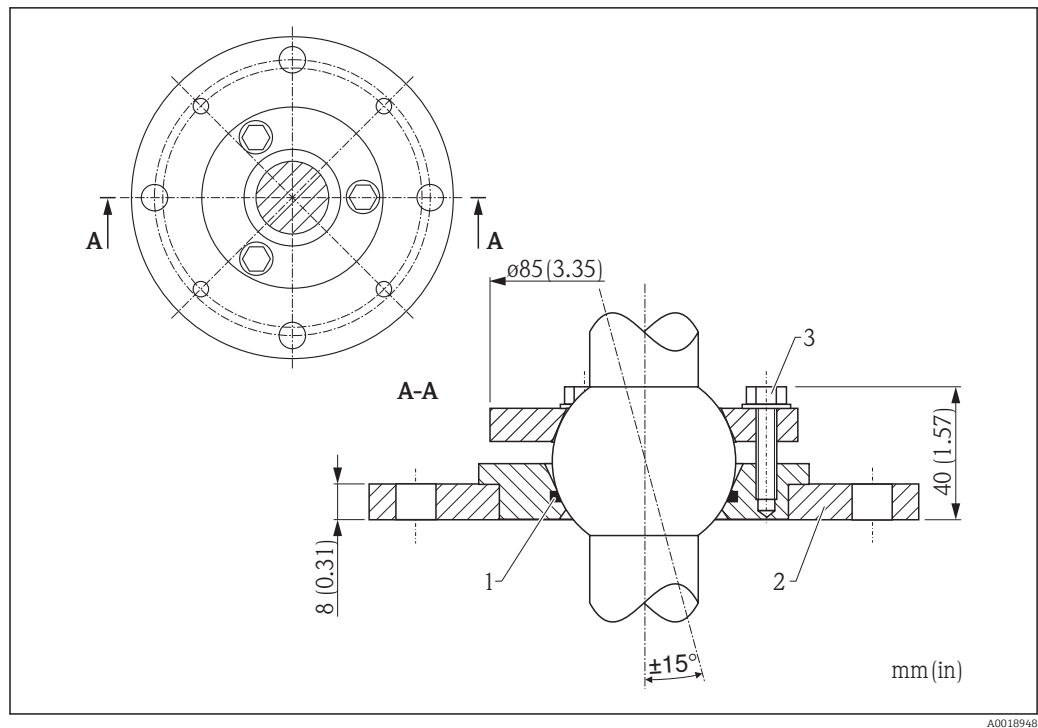

- 1 Viton seal
- 2 UNI flange for FMR57
- 3 Clamping screw 3 x M8, offset by 120°

**i** In the high-temperature version of the FMR57 (feature 090: "Seal", version D4: "Graphite, -40 to 400°C"), there is no Viton seal (1) on the alignment unit.

Weight

Housing

Part	Weight
GT18 housing - stainless steel	Approx. 4.5 kg (9.9 lb)
GT19 housing - plastic	Approx. 1.2 kg (2.7 lb)
GT20 housing - aluminum	Approx. 1.9 kg (4.2 lb)

Antenna and process connection

Device	Weight of antenna/process connection
FMR56	Max. 1.5 kg (3.3 lb) + flange weight <sup>1)</sup>
FMR57	Max. 5.5 kg (12.1 lb) + flange weight <sup>1)</sup>

1) For the flange weight, see Technical Information TI00426F.

**Materials: Housing GT18**  
(stainless steel, corrosion-resistant)

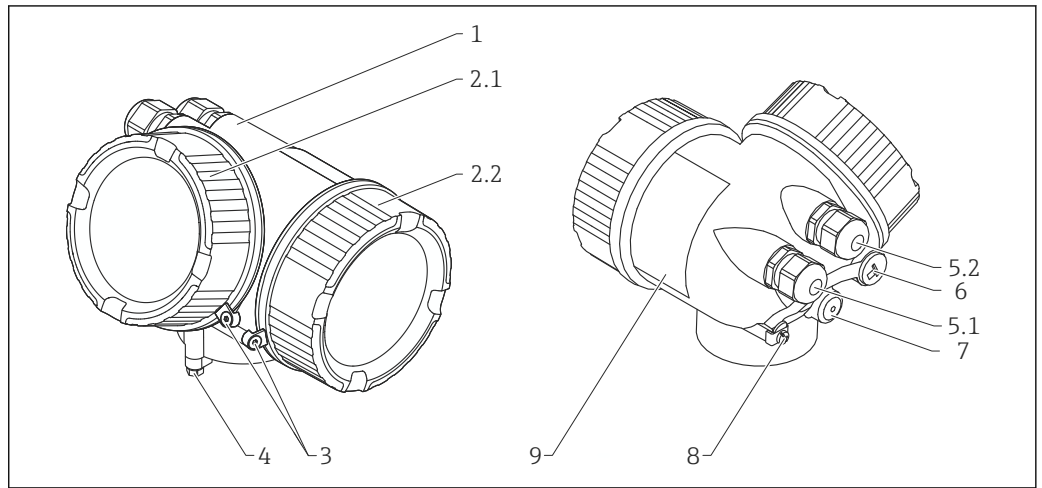

A0036037

No.	Component part	Material
1	Housing	CF3M similar to 316L/1.4404
2.1	Electronics compartment cover	<ul style="list-style-type: none"> <li>■ Cover: CF3M (similar to 316L/ 1.4404)</li> <li>■ Window: glass</li> <li>■ Cover seal: NBR</li> <li>■ Window seal: NBR</li> <li>■ Thread coating: graphite-based lubricant varnish</li> </ul>
2.2	Connection compartment cover	<ul style="list-style-type: none"> <li>■ Cover: CF3M (similar to 316L/ 1.4404)</li> <li>■ Cover seal: NBR</li> <li>■ Thread coating: graphite-based lubricant varnish</li> </ul>
3	Cover clamp	<ul style="list-style-type: none"> <li>■ Screw: A4</li> <li>■ Clamp: 316L (1.4404)</li> </ul>
4	Safety device on housing neck	<ul style="list-style-type: none"> <li>■ Screw: A4-70</li> <li>■ Clamp: 316L (1.4404)</li> </ul>
5.1	Dummy plug, coupling, adapter or connector (depending on device version)	<ul style="list-style-type: none"> <li>■ Dummy plug, depending on device version:                             <ul style="list-style-type: none"> <li>■ PE</li> <li>■ PBT-GF</li> </ul> </li> <li>■ Coupling: 316L (1.4404) or brass, nickel-plated</li> <li>■ Adapter: 316L (1.4404/1.4435)</li> <li>■ Seal: EPDM</li> <li>■ Connector M12: brass, nickel-plated <sup>1)</sup></li> <li>■ Connector 7/8": 316 (1.4401) <sup>2)</sup></li> </ul>
5.2	Dummy plug, coupling or adapter (depending on device version)	<ul style="list-style-type: none"> <li>■ Dummy plug: 316L (1.4404)</li> <li>■ Coupling: 316L (1.4404) or brass, nickel-plated</li> <li>■ Adapter: 316L (1.4404/1.4435)</li> <li>■ Seal: EPDM</li> </ul>
6	Dummy plug or M12 socket (depending on device version)	<ul style="list-style-type: none"> <li>■ Dummy plug: 316L (1.4404)</li> <li>■ M12 socket: 316L (1.4404)</li> </ul>
7	Pressure compensation vent	316L (1.4404)
8	Ground terminal	<ul style="list-style-type: none"> <li>■ Screw: A4</li> <li>■ Spring washer: A4</li> <li>■ Clamp: 316L (1.4404)</li> <li>■ Bracket: 316L (1.4404)</li> </ul>
9	Nameplate	<ul style="list-style-type: none"> <li>■ Plate: 316L (1.4404)</li> <li>■ Groove pin: A4 (1.4571)</li> </ul>

1) In the version with M12 connector, the seal material is Viton.

2) In the version with 7/8" connector, the seal material is NBR.

**Materials: GT19 housing (plastic)**

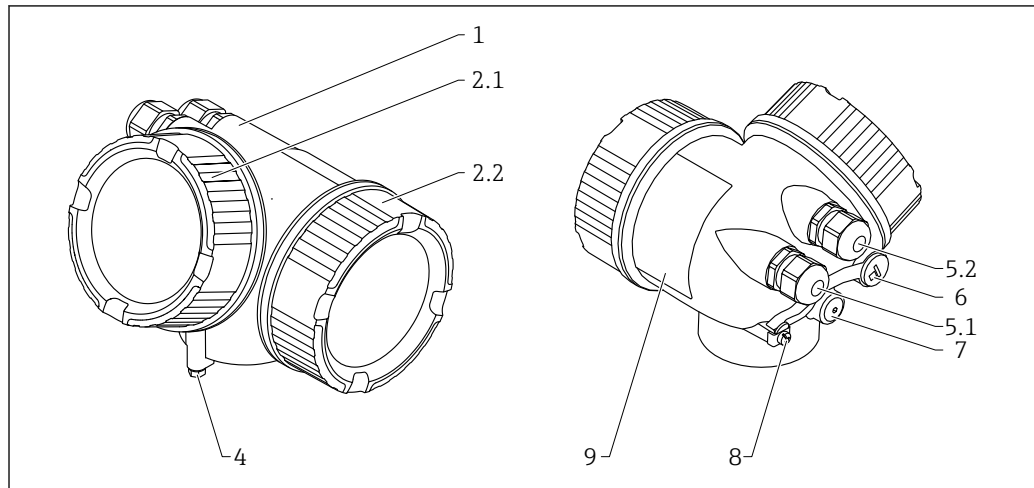

A0013788

No.	Component part	Material
1	Housing	PBT
2.1	Electronics compartment cover	<ul style="list-style-type: none"> <li>▪ Sight glass: PC</li> <li>▪ Rim: PBT-PC</li> <li>▪ Cover seal: EPDM</li> <li>▪ Thread coating: graphite-based lubricant varnish</li> </ul>
2.2	Connection compartment cover	<ul style="list-style-type: none"> <li>▪ Cover: PBT</li> <li>▪ Cover seal: EPDM</li> <li>▪ Thread coating: graphite-based lubricant varnish</li> </ul>
4	Safety device on housing neck	<ul style="list-style-type: none"> <li>▪ Screw: A4-70</li> <li>▪ Clamp: 316L (1.4404)</li> </ul>
5.1	Dummy plug, coupling, adapter or connector (depending on device version)	<ul style="list-style-type: none"> <li>▪ Dummy plug, depending on device version:                             <ul style="list-style-type: none"> <li>▪ PE</li> <li>▪ PBT-GF</li> </ul> </li> <li>▪ Coupling, depending on device version:                             <ul style="list-style-type: none"> <li>▪ Brass (CuZn), nickel-plated</li> <li>▪ PA</li> </ul> </li> <li>▪ Adapter: 316L (1.4404/1.4435)</li> <li>▪ Seal: EPDM</li> <li>▪ Connector M12: brass, nickel-plated <sup>1)</sup></li> <li>▪ Connector 7/8": 316 (1.4401) <sup>2)</sup></li> </ul>
5.2	Dummy plug, coupling or adapter (depending on device version)	<ul style="list-style-type: none"> <li>▪ Dummy plug, depending on device version:                             <ul style="list-style-type: none"> <li>▪ PE</li> <li>▪ PBT-GF</li> <li>▪ Steel, galvanized</li> </ul> </li> <li>▪ Coupling, depending on device version:                             <ul style="list-style-type: none"> <li>▪ Brass (CuZn), nickel-plated</li> <li>▪ PA</li> </ul> </li> <li>▪ Adapter: 316L (1.4404/1.4435)</li> <li>▪ Seal: EPDM</li> </ul>
6	Dummy plug or M12 socket (depending on device version)	<ul style="list-style-type: none"> <li>▪ Dummy plug: brass (CuZn), nickel-plated</li> <li>▪ M12 socket: GD-Zn, nickel-plated</li> </ul>
7	Pressure compensation vent	Brass (CuZn), nickel-plated
8	Ground terminal	<ul style="list-style-type: none"> <li>▪ Screw: A2</li> <li>▪ Spring washer: A4</li> <li>▪ Clamp: 304 (1.4301)</li> <li>▪ Bracket: 304 (1.4301)</li> </ul>
9	Adhesive nameplate	Plastic

1) In the version with M12 connector, the seal material is Viton.

2) In the version with 7/8" connector, the seal material is NBR.



**Materials: GT20 housing  
(die-cast aluminum, powder-coated)**

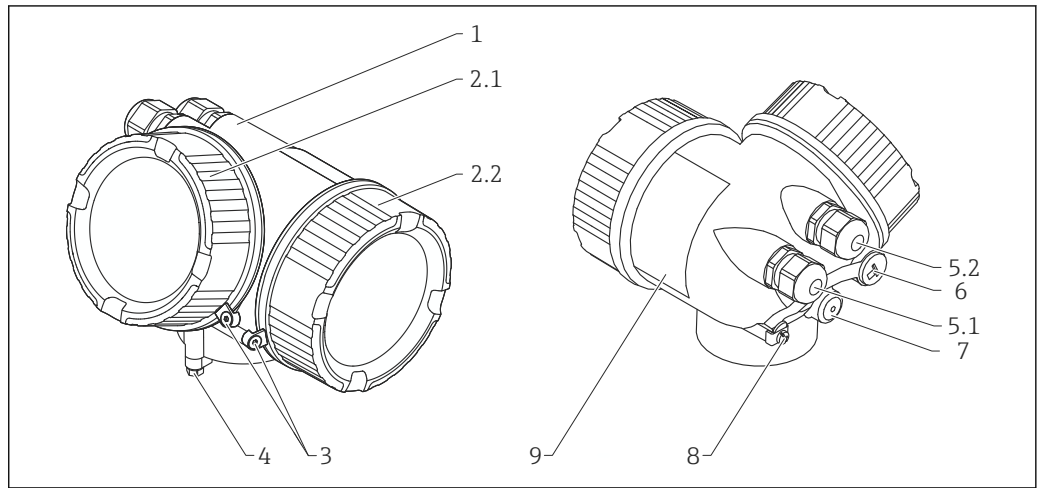

A0036037

No.	Component part	Material
1	Housing, RAL 5012 (blue)	<ul style="list-style-type: none"> <li>■ Housing: AlSi10Mg(&lt;0.1% Cu)</li> <li>■ Coating: polyester</li> </ul>
2.1	Electronics compartment cover, RAL 7035 (gray)	<ul style="list-style-type: none"> <li>■ Cover: AlSi10Mg(&lt;0.1% Cu)</li> <li>■ Window: glass</li> <li>■ Cover seal: NBR</li> <li>■ Window seal: NBR</li> <li>■ Thread coating: graphite-based lubricant varnish</li> </ul>
2.2	Connection compartment cover, RAL 7035 (gray)	<ul style="list-style-type: none"> <li>■ Cover: AlSi10Mg(&lt;0.1% Cu)</li> <li>■ Cover seal: NBR</li> <li>■ Thread coating: graphite-based lubricant varnish</li> </ul>
3	Cover clamp	<ul style="list-style-type: none"> <li>■ Screw: A4</li> <li>■ Clamp: 316L (1.4404)</li> </ul>
4	Safety device on housing neck	<ul style="list-style-type: none"> <li>■ Screw: A4-70</li> <li>■ Clamp: 316L (1.4404)</li> </ul>
5.1	Dummy plug, coupling, adapter or connector (depending on device version)	<ul style="list-style-type: none"> <li>■ Dummy plug, depending on device version:                             <ul style="list-style-type: none"> <li>■ PE</li> <li>■ PBT-GF</li> </ul> </li> <li>■ Coupling, depending on device version:                             <ul style="list-style-type: none"> <li>■ Brass (CuZn), nickel-plated</li> <li>■ PA</li> </ul> </li> <li>■ Adapter: 316L (1.4404/1.4435)</li> <li>■ Seal: EPDM</li> <li>■ M12 plug: brass, nickel-plated <sup>1)</sup></li> <li>■ 7/8" plug: 316 (1.4401) <sup>2)</sup></li> </ul>
5.2	Dummy plug, coupling or adapter (depending on device version)	<ul style="list-style-type: none"> <li>■ Dummy plug, depending on device version:                             <ul style="list-style-type: none"> <li>■ PE</li> <li>■ PBT-GF</li> <li>■ Steel, galvanized</li> </ul> </li> <li>■ Coupling, depending on device version:                             <ul style="list-style-type: none"> <li>■ Brass (CuZn), nickel-plated</li> <li>■ PA</li> </ul> </li> <li>■ Adapter: 316L (1.4404/1.4435)</li> <li>■ Seal: EPDM</li> </ul>
6	Dummy plug or M12 socket (depending on device version)	<ul style="list-style-type: none"> <li>■ Dummy plug: brass (CuZn), nickel-plated</li> <li>■ M12 socket: GD-Zn, nickel-plated</li> </ul>
7	Pressure compensation vent	Brass (CuZn), nickel-plated

No.	Component part	Material
8	Ground terminal	<ul style="list-style-type: none"> <li>■ Screw: A2</li> <li>■ Spring washer: A2</li> <li>■ Clamp: 304 (1.4301)</li> <li>■ Bracket: 304 (1.4301)</li> </ul>
9	Adhesive nameplate	Plastic

- 1) In the version with the M12 plug, the seal material is Viton (different from standard).  
 2) In the version with the 7/8" plug, the seal material is NBR (different from standard).

### Materials: antenna and process connection

### FMR56

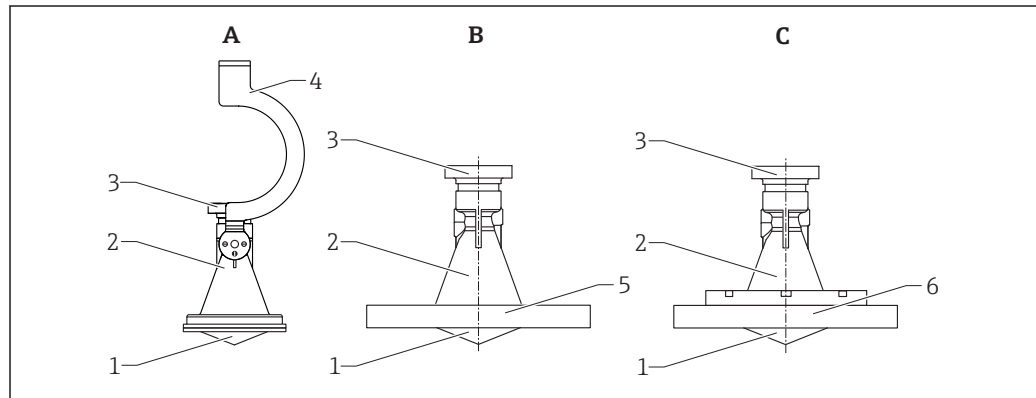

A0018950

- A Standard version with mounting bracket  
 B Horn antenna with slip-on flange  
 C Horn antenna with flange and adapter ring

Item	Component part	Material
1	Focusing lens	PP
	Seal	VMQ
2	Horn	PBT
3	Housing adapter	304 (1.4301)
4	Mounting bracket	304 (1.4301)
	Screw	A2
	Nordlock washer	A4
5	Slip-on flange	PP
6	Flange + adapter ring	PP
	Screw	A2
	Seal	FKM

FMR57

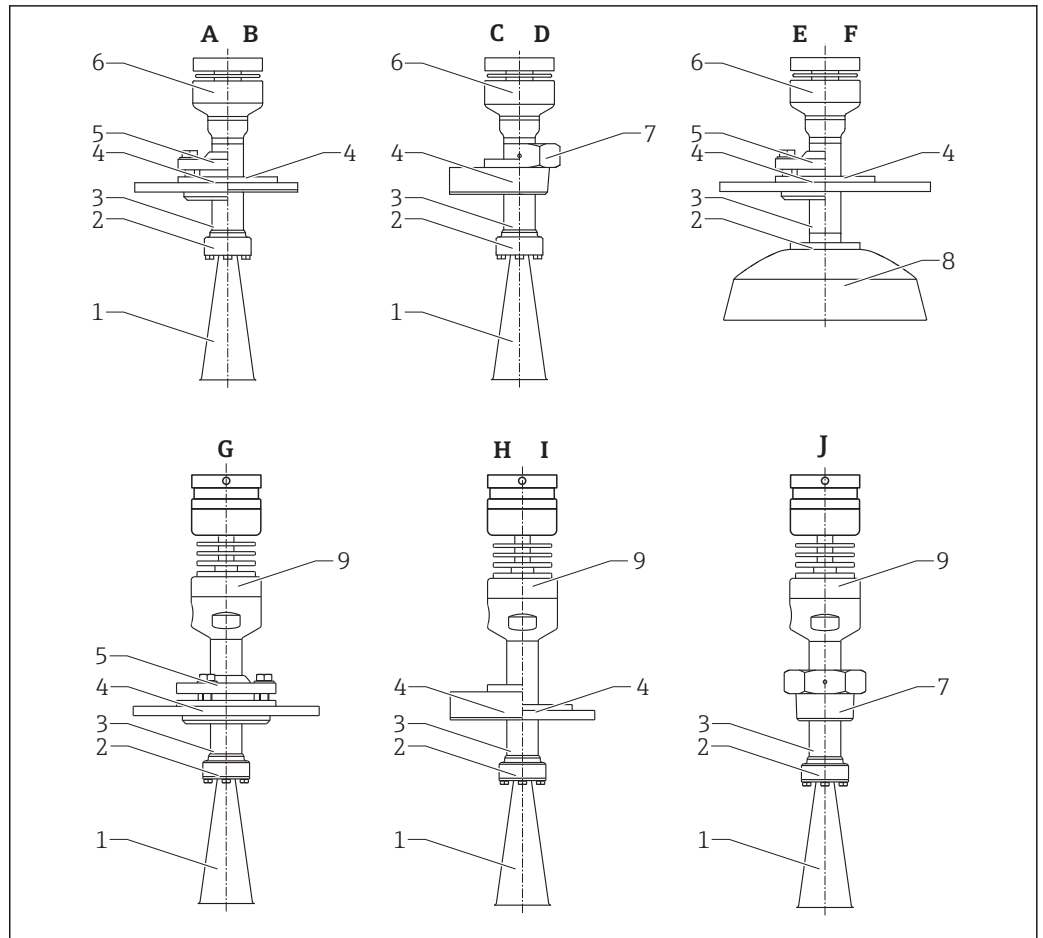

A0018958

- A *Horn standard version with alignment unit and UNI flange*
- B *Horn standard version with UNI flange*
- C *Horn standard version with standard flange*
- D *Horn standard version with threaded adapter*
- E *Parabolic version with alignment unit and UNI flange*
- F *Parabolic version with UNI flange*
- G *Horn high-temperature version with alignment unit and UNI flange*
- H *Horn high-temperature version with standard flange*
- I *Horn high-temperature version with UNI flange*
- J *Horn high-temperature version with threaded connection*

Item	Component part	Material	
1	Horn	316L (1.4404)	
	Screws	A4	
	Process separation cone	Standard: PEEK	High temperature: PI
	Seal	Standard: FKM	High temperature: graphite
2	Process separators	316L (1.4404)	
	Horn/parabolic adapter	316L (1.4404)	
3	Pipe	316L (1.4404)	
4	Flange	316L (1.4404/1.4435)	
	Adapter	316L (1.4404)	
5	Bearing	316L (1.4404)	
	Screws	A2	
	Spring ring	1.4310	

Item	Component part	Material	
	Clamping flange	316L (1.4404)	
	Seal (except for version "G")	FKM	
6	Housing adapter	316L (1.4404)	
	Plug	A4	316L (1.4404)
	Adapter (G→NPT)	316L (1.4404)	
	Seal	FKM	PTFE (tape)
7	Process connection	316L (1.4404)	
8	Parabolic mirror	316L (1.4404)	
	Screws	A4	
	Feed	PTFE	
	Seal	FKM	
9	Housing adapter	316L (1.4404)	
	Temperature reduction	316L (1.4404)	
	Intermediate adapter	316L (1.4404)	
	Purge air adapter	316L (1.4404)	
	Plug	A4	316L (1.4404)
	Adapter (G→NPT)	316L (1.4404)	

**Materials: Weather protection cover**

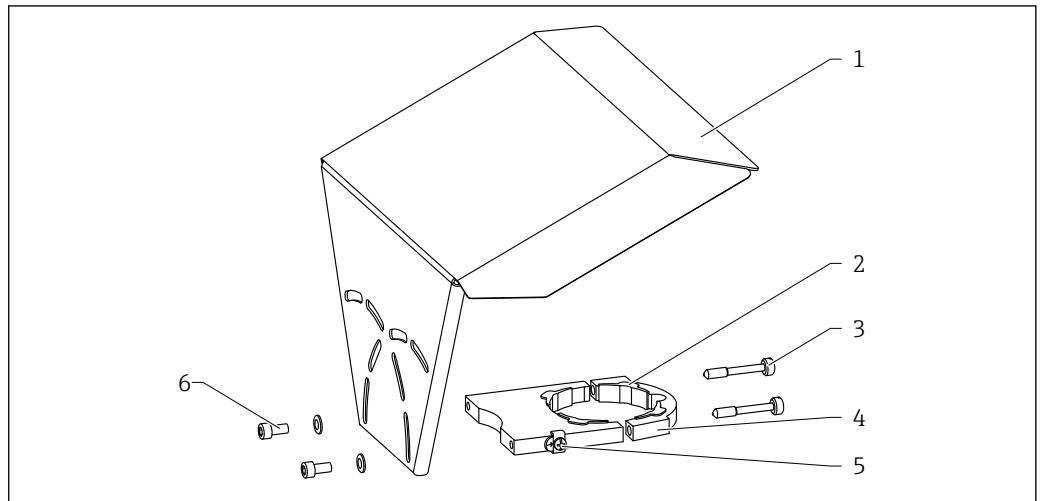

A0015473

No.	Component: Material
1	Protection cover: 316L (1.4404)
2	Rubber molded part (4x): EPDM
3	Tensioning screw: 316L (1.4404) + carbon thread
4	Holder: 316L (1.4404)
5	Ground terminal <ul style="list-style-type: none"> <li>▪ Screw: A4</li> <li>▪ Spring washer: A4</li> <li>▪ Clamp: 316L (1.4404)</li> <li>▪ Bracket: 316L (1.4404)</li> </ul>
6	<ul style="list-style-type: none"> <li>▪ Washer: A4</li> <li>▪ Cylinder screw: A4-70</li> </ul>

## Operability

### Operating concept

#### Operator-oriented menu structure for user-specific tasks

- Commissioning
- Operation
- Diagnostics
- Expert level

#### Operating languages

- English
- Deutsch
- Français
- Español
- Italiano
- Nederlands
- Portuguesa
- Polski
- русский язык (Russian)
- Svenska
- Türkçe
- 中文 (Chinese)
- 日本語 (Japanese)
- 한국어 (Korean)
- Bahasa Indonesia
- tiếng Việt (Vietnamese)
- čeština (Czech)



Feature 500 of the product structure determines which of these languages is preset on delivery.

#### Quick and save commissioning

- Interactive wizard with graphical interface for easy commissioning via FieldCare/DeviceCare
- Menu guidance with brief explanations of the individual parameter functions
- Standardized operation at the device and in the operating tools

#### Integrated data storage device (HistoROM)

- Enables transfer of configuration when changing electronic modules
- Records up to 100 event messages in the device
- Records up to 1000 measured values in the device
- Saves the signal curve on commissioning which can later be used as a reference.

#### Efficient diagnostics increase measurement reliability

- Remedy information is integrated in plain text
- Diverse simulation options and line recorder functions

#### Integrated Bluetooth module (option for HART devices)

- Easy and fast setup via SmartBlue (app)
- No additional tools or adapters required
- Signal curve via SmartBlue (app)
- Encrypted single point-to-point data transmission (Fraunhofer-Institut, third party, tested) and password-protected communication via Bluetooth® wireless technology

**Local operation**

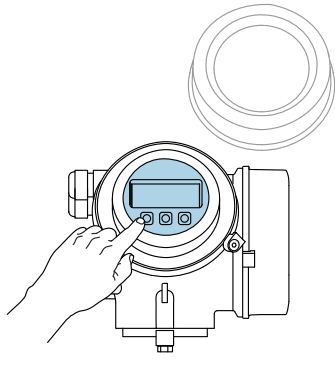
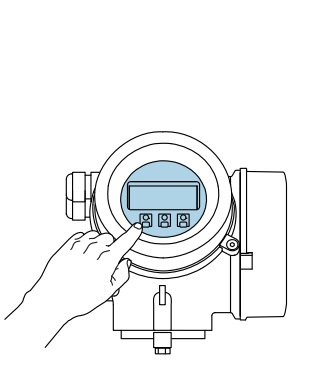
Operation with	Pushbuttons	Touch Control
Order code for "Display; Operation"	Option C "SD02"	Option E "SD03"
		
Display elements	4-line display	4-line display white background lighting; switches to red in event of device error
	Format for displaying measured variables and status variables can be individually configured	
	Permitted ambient temperature for the display: -20 to +70 °C (-4 to +158 °F) The readability of the display may be impaired at temperatures outside the temperature range.	
Operating elements	local operation with 3 push buttons (⊕, ⊖, ⊞)	external operation via touch control; 3 optical keys: ⊕, ⊖, ⊞
	Operating elements also accessible in various hazardous areas	
Additional functionality	Data backup function The device configuration can be saved in the display module.	
	Data comparison function The device configuration saved in the display module can be compared to the current device configuration.	
	Data transfer function The transmitter configuration can be transmitted to another device using the display module.	

**Operation with remote display and operating module FHX50**

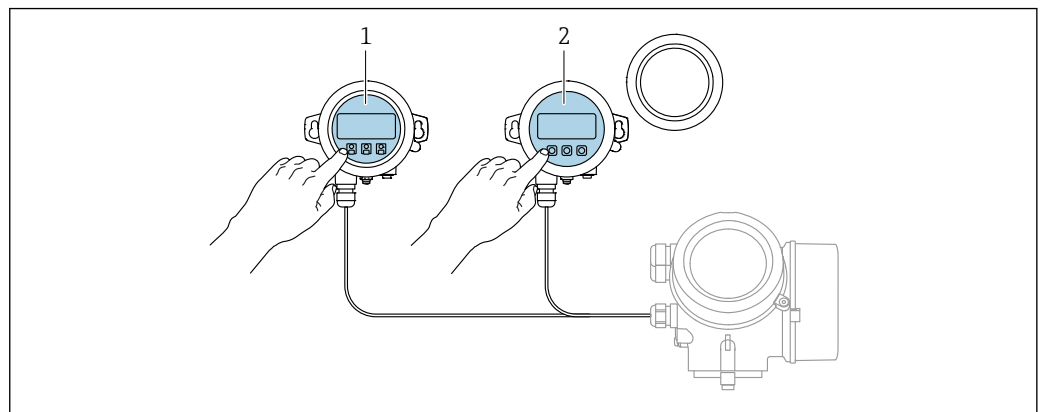

39 FHX50 operating options

- 1 Display and operating module SD03, optical keys; can be operated through the glass of the cover
- 2 Display and operating module SD02, push buttons; cover must be removed

## Operation via Bluetooth® wireless technology

### Requirements

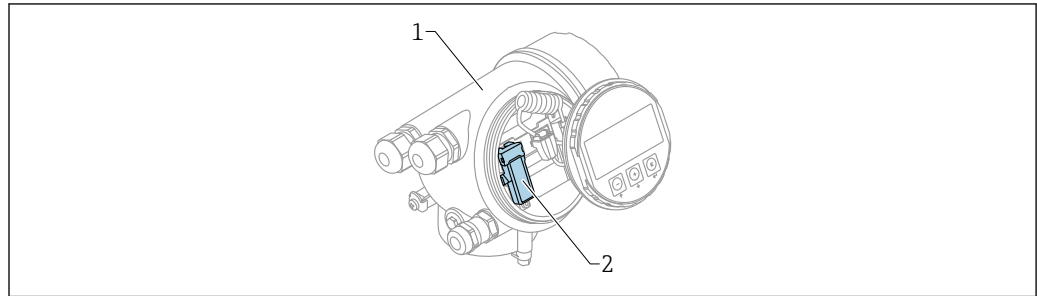

A0036790

#### 40 Device with Bluetooth module

- 1 Electronics housing of the device
- 2 Bluetooth module

This operation option is only available for devices with Bluetooth module. There are the following options:

- The device has been ordered with a Bluetooth module:  
Feature 610 "Accessory Mounted", option NF "Bluetooth"
- The Bluetooth module has been ordered as an accessory (ordering number: 71377355) and has been mounted. See Special Documentation SDO2252F.

### Operation via SmartBlue (app)

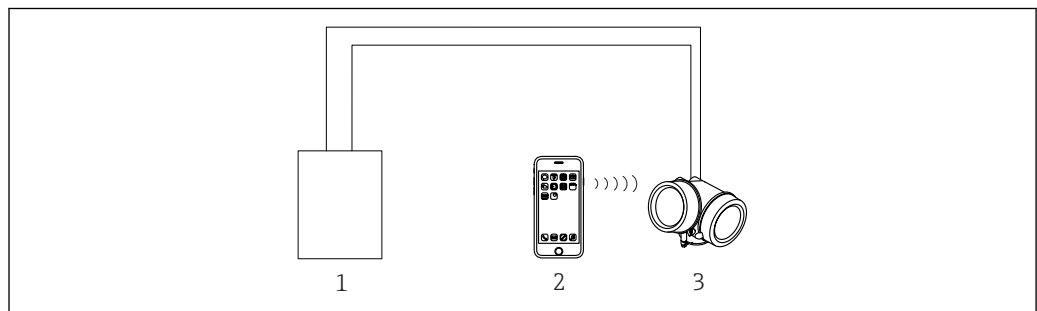

A0034939

#### 41 Operation via SmartBlue (app)

- 1 Transmitter power supply unit
- 2 Smartphone / tablet with SmartBlue (app)
- 3 Transmitter with Bluetooth module



Remote operation

Via HART protocol

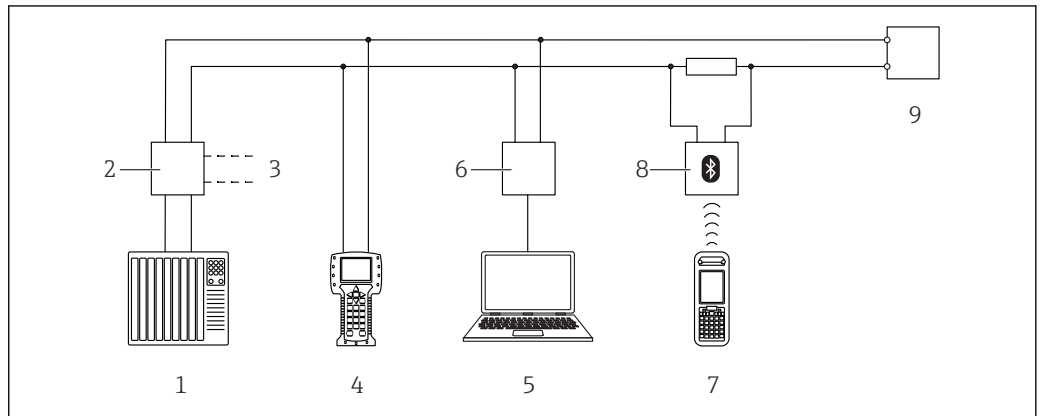

A0036169

42 Options for remote operation via HART protocol

- 1 PLC (Programmable Logic Controller)
- 2 Transmitter power supply unit, e.g. RN221N (with communication resistor)
- 3 Connection for Commubox FXA191, FXA195 and Field Communicator 375, 475
- 4 Field Communicator 475
- 5 Computer with operating tool (e.g. DeviceCare/FieldCare, AMS Device Manager, SIMATIC PDM)
- 6 Commubox FXA191 (RS232) or FXA195 (USB)
- 7 Field Xpert SFX350/SFX370
- 8 VIATOR Bluetooth modem with connecting cable
- 9 Transmitter

Via PROFIBUS PA protocol

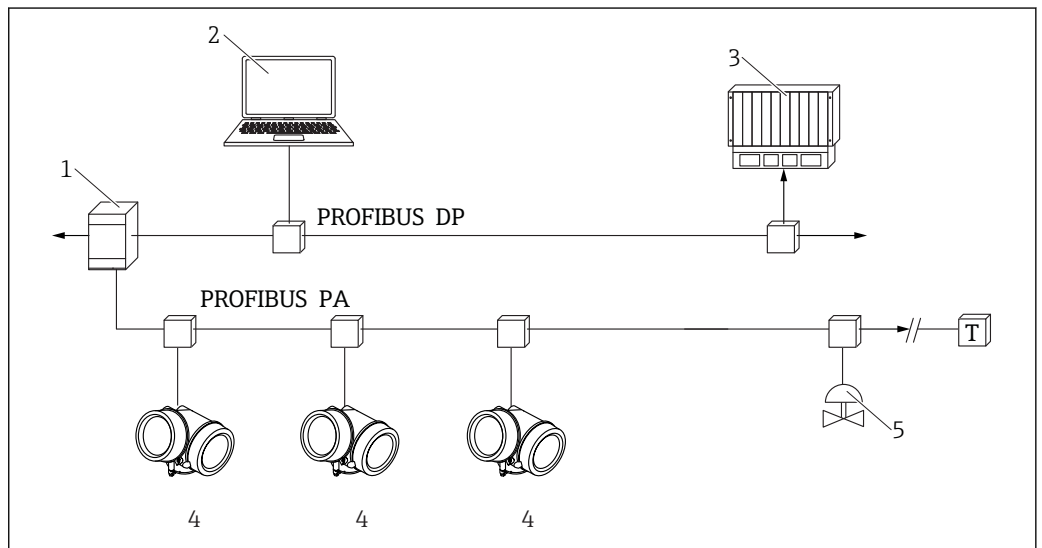

A0036301

43 Options for remote operation via PROFIBUS PA protocol

- 1 Segment coupler
- 2 Computer with Profiboard/Proficard and operating tool (e.g. DeviceCare/FieldCare)
- 3 PLC (Programmable Logic Controller)
- 4 Transmitter
- 5 Additional functions (valves etc.)

Via FOUNDATION Fieldbus

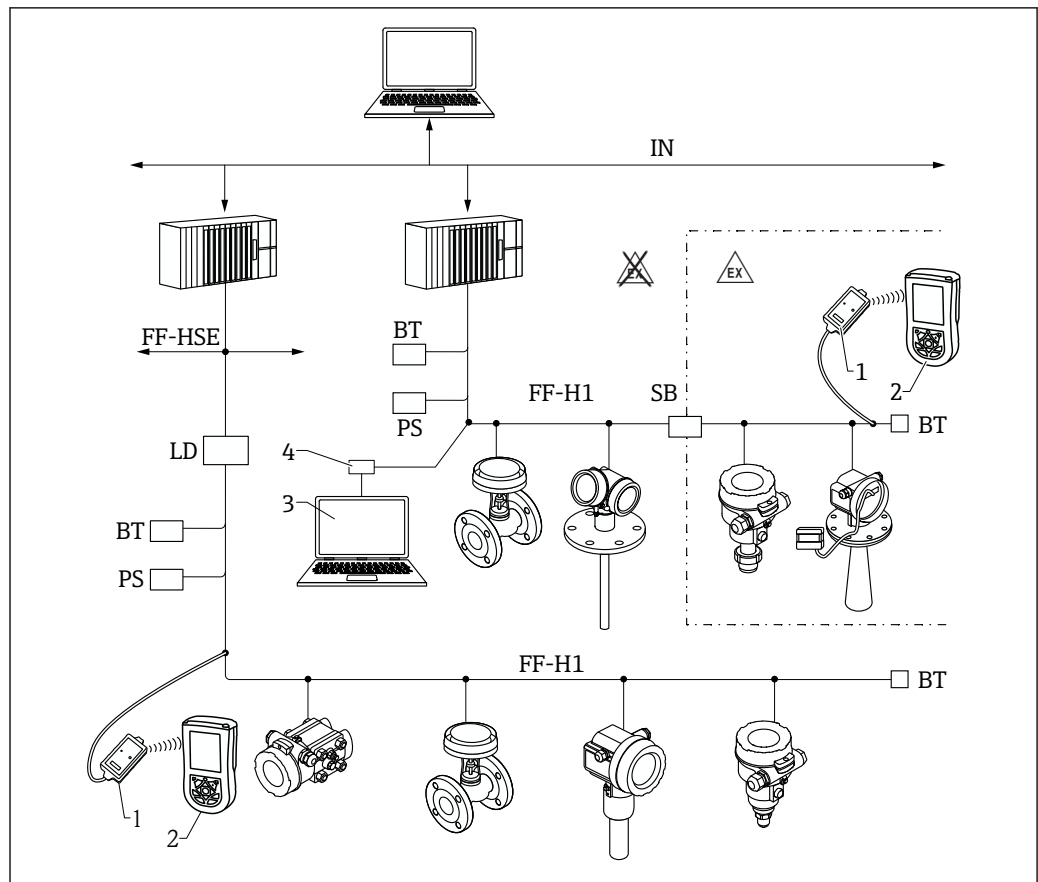

A0017188

44 FOUNDATION Fieldbus system architecture with associated components

- 1 FFblue Bluetooth modem
- 2 Field Xpert SFX350/SFX370
- 3 DeviceCare/FieldCare
- 4 NI-FF interface card

IN	Industrial network
FF-HSE	High Speed Ethernet
FF-H1	FOUNDATION Fieldbus-H1
LD	Linking Device FF-HSE/FF-H1
PS	Bus Power Supply
SB	Safety Barrier
BT	Bus Terminator



---

**SupplyCare inventory management software**

SupplyCare is a web-based operating program for coordinating the flow of material and information along the supply chain. SupplyCare provides a comprehensive overview of the levels of geographically distributed tanks and silos, for instance, providing complete transparency over the current inventory situation, regardless of time and location.

Based on the measuring and transmission technology installed onsite, the current inventory data are collected and sent to SupplyCare. Critical levels are clearly indicated and calculated forecasts provide additional security for material requirements planning.

The main functions of SupplyCare:

**Inventory visualization**

SupplyCare determines the inventory levels in tanks and silos at regular intervals. It displays current and historical inventory data and calculated forecasts of future demand. The overview page can be configured to suit the user's preferences.

**Master data management**

With SupplyCare you can create and manage the master data for locations, companies, tanks, products and users, as well as user authorization.

**Report Configurator**

The Report Configurator can be used to create personalized reports quickly and easily. The reports can be saved in a variety of formats, such as Excel, PDF, CSV and XML. The reports can be transmitted in many ways, such as by http, ftp or e-mail.

**Event management**

Events, such as when levels drop below the safety stock level or plan points, are indicated by the software. In addition, SupplyCare can also notify pre-defined users by e-mail.

**Alarms**

If technical problems occur, e.g. connection issues, alarms are triggered and alarm e-mails are sent to the System Administrator and the Local System Administrator.

**Delivery planning**

The integrated delivery planning function automatically generates an order proposal if a pre-set minimum inventory level is undershot. Scheduled deliveries and disposals are monitored continuously by SupplyCare. SupplyCare notifies the user if scheduled deliveries and disposals are not going to be met as planned.

**Analysis**

In the Analysis module, the most important indicators for the inflow and outflow of the individual tanks are calculated and displayed as data and charts. Key indicators of material management are automatically calculated and form the basis for optimizing the delivery and storage process.

**Geographical visualization**

All the tanks and the tank inventories are represented graphically on a map (based on Google Maps). The tanks and inventory situations can be filtered by tank group, product, supplier or location.

**Multi-language support**

The multi-language user interface supports 9 languages, thereby enabling global collaboration on a single platform. The language and settings are recognized automatically using the browser settings.

**SupplyCare Enterprise**

SupplyCare Enterprise runs by default as a service under Microsoft Windows on an application server in an Apache Tomcat environment. The operators and administrators operate the application via a Web browser from their workstations.

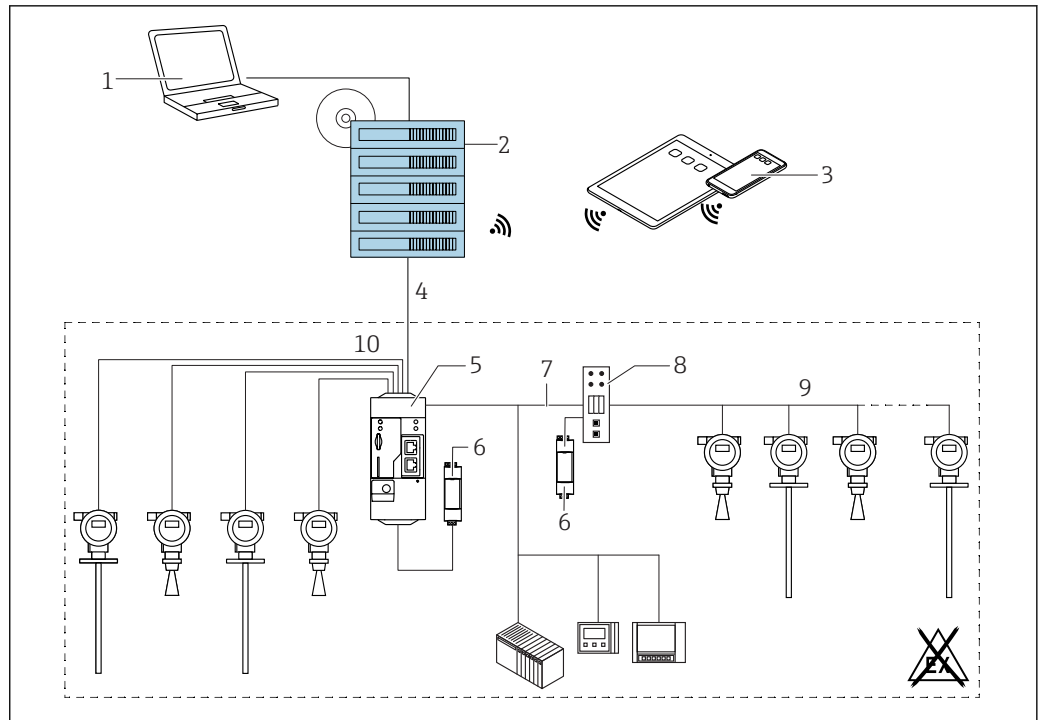

A0034288

46 Example of inventory management platform with SupplyCare Enterprise SCE30B

- 1 SupplyCare Enterprise (via Web browser)
- 2 SupplyCare Enterprise installation
- 3 SupplyCare Enterprise on mobile devices (via Web browser)
- 4 Ethernet/WLAN/UMTS
- 5 Fieldgate FXA42
- 6 Power supply 24 V DC
- 7 Modbus TCP via Ethernet as server/client
- 8 Converter from Modbus to HART Multidrop
- 9 HART Multidrop
- 10 4 x 4 to 20 mA analog input (2-wire/4-wire)

### Cloud-based application: SupplyCare Hosting

SupplyCare Hosting is offered as a hosting service (software as a service). Here, the software is installed within the Endress+Hauser IT infrastructure and made available to the user in the Endress+Hauser portal.

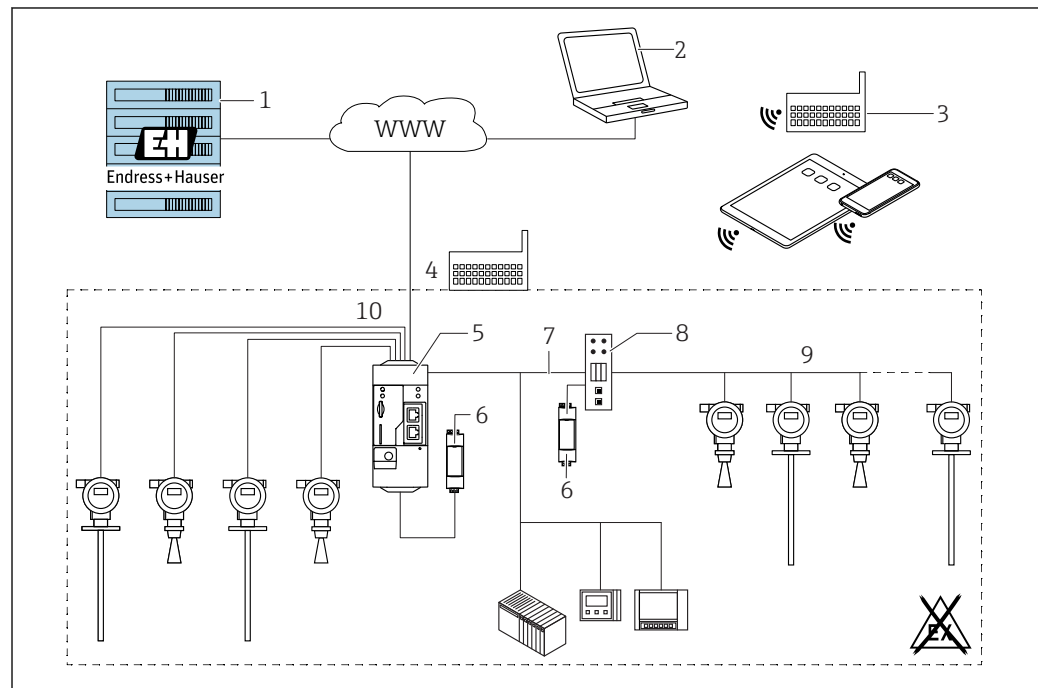

A0034289

47 Example of inventory management platform with SupplyCare Hosting SCH30

- 1 SupplyCare Hosting installation in Endress+Hauser data center
- 2 PC workstation with Internet connection
- 3 Warehouse locations with Internet connection via 2G/3G with FXA42 or FXA30
- 4 Warehouse locations with Internet connection with FXA42
- 5 Fieldgate FXA42
- 6 Power supply 24 V DC
- 7 Modbus TCP via Ethernet as server/client
- 8 Converter from Modbus to HART Multidrop
- 9 HART Multidrop
- 10 4 x 4 to 20 mA analog input (2-wire/4-wire)

With SupplyCare Hosting, users do not need to make the initial software purchase or install and run the IT infrastructure needed. Endress+Hauser constantly update SupplyCare Hosting and enhance the capability of the software in conjunction with the customer. The hosted version of SupplyCare is thus always up-to-date and can be customized to meet different customer requirements. Other services are also offered in addition to the IT infrastructure and the software that is installed in a secure, redundant Endress+Hauser data center. These services include defined availability of the global Endress+Hauser Service and Support Organization and defined response times in a service event.

## Certificates and approvals



Currently available certificates and approvals can be called up via the product configurator.

**CE mark** The measuring system meets the legal requirements of the applicable EU Directives. These are listed in the corresponding EU Declaration of Conformity along with the standards applied.  
Endress+Hauser confirms successful testing of the device by affixing to it the CE mark.

**RoHS** The measuring system complies with the substance restrictions of the Restriction on Hazardous Substances Directive 2011/65/EU (RoHS 2).

**RCM-Tick marking** The supplied product or measuring system meets the ACMA (Australian Communications and Media Authority) requirements for network integrity, interoperability, performance characteristics as well as health and safety regulations. Here, especially the regulatory arrangements for electromagnetic compatibility are met. The products are labelled with the RCM- Tick marking on the name plate.



A0029561

**Ex approval**

- ATEX
- IEC Ex
- CSA
- FM
- NEPSI
- KC
- INMETRO
- JPN

Additional safety instructions must be followed for use in hazardous areas. Please refer to the separate "Safety Instructions" (XA) document included in the delivery. Reference to the applicable XA can be found on the nameplate.

**Dual seal according to ANSI/ISA 12.27.01** The devices have been designed according to ANSI/ISA 12.27.01 as dual seal devices, allowing the user to waive the use and save the cost of installing external secondary process seals in the conduit as required by the process sealing sections of ANSI/NFPA 70 (NEC) and CSA 22.1 (CEC) These instruments comply with the North-American installation practice and provide a very safe and cost-saving installation for pressurized applications with hazardous fluids.  
Further information can be found in the Safety Instructions (XA) of the relevant devices.

**Functional safety** Use for level monitoring (MIN, MAX, range) up to SIL 3 (homogeneous or diverse redundancy), independently evaluated by TÜV Rheinland in accordance with IEC 61508, refer to the "Functional Safety Manual" for information.

**WHG** WHG approval: Z-65.16-524

**Pressure equipment with allowable pressure ≤ 200 bar (2 900 psi)** Pressure instruments with a flange and threaded boss that do not have a pressurized housing do not fall within the scope of the Pressure Equipment Directive, irrespective of the maximum allowable pressure.

**Reasons:**  
According to Article 2, point 5 of EU Directive 2014/68/EU, pressure accessories are defined as "devices with an operational function and having pressure-bearing housings".  
If a pressure instrument does not have a pressure-bearing housing (no identifiable pressure chamber of its own), there is no pressure accessory present within the meaning of the Directive.

**Marine approval**

Device	Marine approval <sup>1)</sup>				
	GL	ABS	LR	BV	DNV
FMR56	-	-	-	-	-
FMR57	✓	✓	✓	✓	✓

1) See order code for 590 "Additional approval"

**Radio standard EN 302729**

The Micropilot FMR56 and FMR57 devices comply with the LPR (Level Probing Radar) radio standard EN 302729. The devices are approved for unrestricted use inside and outside of closed vessels in countries of the EU and EFTA. As a prerequisite, the countries in question must have already implemented this standard.

The following countries are those that have currently implemented the standard:

Belgium, Bulgaria, Germany, Denmark, Estonia, France, Greece, UK, Ireland, Iceland, Italy, Liechtenstein, Lithuania, Latvia, Malta, The Netherlands, Norway, Austria, Poland, Portugal, Romania, Sweden, Switzerland, Slovakia, Spain, Czech Republic and Cyprus.

Implementation is still underway in all of the countries not listed.

Please note the following for the operation of the devices outside of closed vessels:

1. Installation must be carried out by properly trained, expert staff.
2. The device antenna must be installed in a fixed location pointing vertically downwards.
3. The installation site must be located at a distance of 4 km from the astronomy stations listed below or otherwise approval must be provided by the relevant authority. If the device is installed at a distance of 4 to 40 km from one of the listed stations, it must not be installed at a height of more than 15 m (49 ft) above the ground.

*Astronomy stations*

Country	Name of the station	Latitude	Longitude
Germany	Effelsberg	50°31'32" North	06°53'00" East
Finland	Metsähovi	60°13'04" North	24°23'37" East
	Tuorla	60°24'56" North	24°26'31" East
France	Plateau de Bure	44°38'01" North	05°54'26" East
	Floirac	44°50'10" North	00°31'37" West
Great Britain	Cambridge	52°09'59" North	00°02'20" East
	Damhall	53°09'22" North	02°32'03" West
	Jodrell Bank	53°14'10" North	02°18'26" West
	Knockin	52°47'24" North	02°59'45" West
	Pickmere	53°17'18" North	02°26'38" West
Italy	Medicina	44°31'14" North	11°38'49" East
	Noto	36°52'34" North	14°59'21" East
	Sardinia	39°29'50" North	09°14'40" East
Poland	Fort Skala Krakow	50°03'18" North	19°49'36" East
Russia	Dmitrov	56°26'00" North	37°27'00" East
	Kalyazin	57°13'22" North	37°54'01" East
	Pushchino	54°49'00" North	37°40'00" East
	Zelenchukskaya	43°49'53" North	41°35'32" East
Sweden	Onsala	57°23'45" North	11°55'35" East
Switzerland	Bleien	47°20'26" North	08°06'44" East
Spain	Yebes	40°31'27" North	03°05'22" West



Country	Name of the station	Latitude	Longitude
	Robledo	40°25'38" North	04°14'57" West
Hungary	Penc	47°47'22" North	19°16'53" East

 As a general rule, the requirements outlined in EN 302729 must be observed.

**FCC**

This device complies with Part 15 of the FCC rules. Operation is subject to the following two conditions: (1) This device may not cause harmful interference, and (2) this device must accept any interference received, including interference that may cause undesired operation.

[Any] changes or modifications not expressly approved by the party responsible for compliance could void the user's authority to operate the equipment.

The devices are compliant with the FCC Code of Federal Regulations, CFR 47, Part 15, Sections 15.205, 15.207, 15.209.

**Industry Canada**

**Canada CNR-Gen Section 7.1.3**

This device complies with Industry Canada licence-exempt RSS standard(s). Operation is subject to the following two conditions: (1) This device may not interference, and (2) this device must accept any interference, including interference that may cause undesired operation of the device.

*Le présent appareil est conforme aux CNR d'Industrie Canada applicables aux appareils radio exempts de licence. L'exploitation est autorisée aux deux conditions suivantes : (1) l'appareil ne doit pas produire de brouillage, et (2) l'utilisateur de l'appareil doit accepter tout brouillage radioélectrique subi, même si le brouillage est susceptible d'en compromettre le fonctionnement.*

[Any] changes or modifications not expressly approved by the party responsible for compliance could void the user's authority to operate the equipment.

- The installation of the LPR/TLPR device shall be done by trained installers, in strict compliance with the manufacturer's instructions.
- The use of this device is on a "no-interference, no-protection" basis. That is, the user shall accept operations of high-powered radar in the same frequency band which may interfere with or damage this device. However, devices found to interfere with primary licensing operations will be required to be removed at the user's expense.
- This device shall be installed and operated in a completely enclosed container to prevent RF emissions, which can otherwise interfere with aeronautical navigation.
- The installer/user of this device shall ensure that it is at least 10 km from the Dominion Astrophysical Radio Observatory (DRAO) near Penticton, British Columbia. The coordinates of the DRAO are latitude 49°19'15" N and longitude 119°37'12" W. For devices not meeting this 10 km separation (e.g., those in the Okanagan Valley, British Columbia,) the installer/user must coordinate with, and obtain the written concurrence of, the Director of the DRAO before the equipment can be installed or operated. The Director of the DRAO may be contacted at 250-497-2300 (tel.) or 250-497-2355 (fax). (Alternatively, the Manager, Regulatory Standards Industry Canada, may be contacted.)

**Japanese radio approval**

The devices comply with Japanese Radio Law, Article 6, Section 1(1)



**CRN approval**

A CRN approval is available for some device versions. Devices are CRN approved if the following two conditions are met:

- The device has a CSA approval (product structure: feature 010 "Approval")
- The device has a CRN-approved process connection as per the following table:

Feature 100 in the product structure	Process connection
AGJ	NPS 3" Cl.150 RF, 316/316L
AHJ	NPS 4" Cl.150 RF, 316/316L
RGJ	Thread ANSI MNPT1-1/2, 316L
RVJ	Thread EN10226 R1-1/2, 316L
XWG	UNI slip-on flange 3"/DN80/80, PP

Feature 100 in the product structure	Process connection
XZG	UNI slip-on flange 4"/DN100/100, PP
XOG	UNI slip-on flange 6"/DN150/150, PP

-  Process connections that do not have CRN approval are not listed in this table.
- Please refer to the product structure to discover which process connections are available for a specific device type.
  - A CRN approval is available on request for some process connections not listed in the product structure.
  - CRN-approved devices are labeled with registration number OF15872.5C on the nameplate.
-  An additional pressure restriction applies for the device versions listed in the table below if they are CRN-approved. The pressure range indicated in the "Process" section continues to apply for device versions not listed in the table below.

Product	Antenna <sup>1)</sup>	Process connection <sup>2)</sup>	Seal <sup>3)</sup>	Max. pressure
FMR50/FMR56	BN: horn 80mm/3"	XWG: UNI slip-on flange 3"		1.6 bar (23.2 psi)
		XZG: UNI slip-on flange 4"		1.5 bar (21.75 psi)
		XOG: UNI slip-on flange 6"		1.5 bar (21.75 psi)
	BR: horn 100mm/4"	XZG: UNI slip-on flange 4"		12 bar (17.4 psi)
		XOG: UNI slip-on flange 6"		1.8 bar (26.1 psi)

- 1) Feature 070 in the product structure
- 2) Feature 100 in the product structure
- 3) Feature 090 in the product structure

**Test, certificate**

Feature 580 "Test, certificate"	Designation
JD	3.1 Material certificate, pressurized parts, EN10204-3.1 inspection certificate
KV	Declaration of Conformity ASME B31.3: The construction, the material used, the pressure and temperature ranges and the labeling of the devices meet the requirements of ASME B31.3

-  Test reports, declarations and inspection certificates are available in electronic format in the *W@M Device Viewer*:  
Enter the serial number that appears on the device ([www.endress.com/deviceviewer](http://www.endress.com/deviceviewer))  
This concerns the options for the following order codes:
- 550 "Calibration"
  - 580 "Test, certificate"

**Hard-copy product documentation**

Hard-copy versions of the test reports, declarations and inspection certificates can also be order via order code 570 "Service", option I7 "Hard-copy product documentation". The documents are then supplied with the product.

---

**Other standards and guidelines**

- EN 60529  
Degrees of protection provided by enclosures (IP code)
- EN 61010-1  
Safety Requirements for Electrical Equipment for Measurement, Control and Laboratory Use
- IEC/EN 61326  
"Emission in accordance with Class A requirements". Electromagnetic compatibility (EMC requirements).
- NAMUR NE 21  
Electromagnetic compatibility (EMC) of industrial process and laboratory control equipment
- NAMUR NE 43  
Standardization of the signal level for the breakdown information of digital transmitters with analog output signal.
- NAMUR NE 53  
Software of field devices and signal-processing devices with digital electronics
- NAMUR NE 107  
Status classification as per NE107
- NAMUR NE 131  
Requirements for field devices for standard applications.
- IEC61508  
Functional safety of safety-related electric/electronic/programmable electronic systems

## Ordering information

---

### Ordering information

Detailed ordering information is available for your nearest sales organization [www.addresses.endress.com](http://www.addresses.endress.com) or in the Product Configurator under [www.endress.com](http://www.endress.com) :

1. Click Corporate
2. Select the country
3. Click Products
4. Select the product using the filters and search field
5. Open the product page

The Configuration button to the right of the product image opens the Product Configurator.



#### **Product Configurator - the tool for individual product configuration**

- Up-to-the-minute configuration data
- Depending on the device: Direct input of measuring point-specific information such as measuring range or operating language
- Automatic verification of exclusion criteria
- Automatic creation of the order code and its breakdown in PDF or Excel output format
- Ability to order directly in the Endress+Hauser Online Shop

**3-point linearity protocol**

 The following points must be considered if option F3 (3-point linearity protocol) was selected in feature 550 ("Calibration").

The 3 points of the linearity protocol are defined as follows:

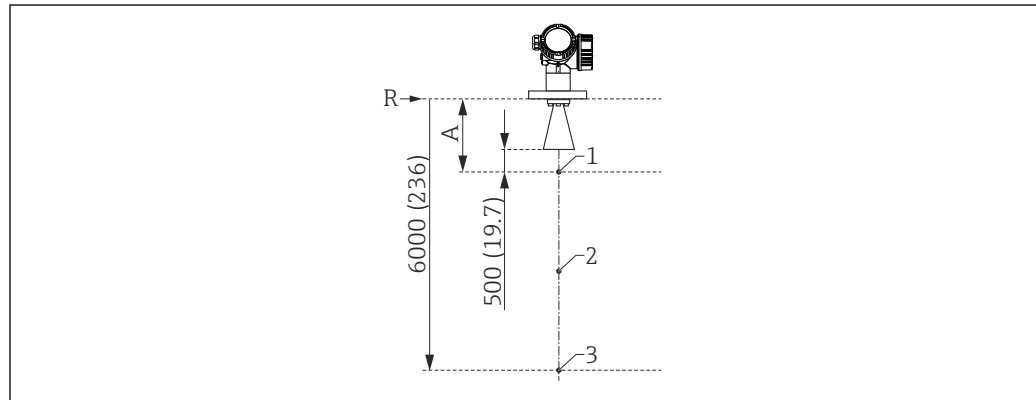

A0023272

 48 Points of the 3-point linearity protocol; engineering unit: mm (in)

A Distance from the reference point R to the first measuring point

R Reference point of measurement

1 First measuring point

2 Second measuring point (in the middle between the first and third measuring point)

3 Third measuring point

Measuring point	Item
1st measuring point	<ul style="list-style-type: none"> <li>■ At a distance A from the reference point</li> <li>■ A = length of antenna + antenna extension where applicable + 500 mm (19.7 in)</li> <li>■ Minimum distance: <math>A_{\min} = 1000</math> mm (39.4 in)</li> </ul>
2nd measuring point	In the middle between the 1st and 3rd measuring point
3rd measuring point	6 000 mm (236 in) below the reference point R

 The position of the measuring points can vary by  $\pm 1$  cm ( $\pm 0.04$  in).

 The linearity check is performed under reference operating conditions.

**5-point linearity protocol**

**i** The following points must be considered if option F4 (5-point linearity protocol) was selected in feature 550 ("Calibration").

The 5 points of the linearity protocol are evenly distributed over the measuring range (0% - 100%). **Empty calibration** (E) and **Full calibration** (F) must be specified in order to define the measuring range<sup>2)</sup>.

The following restrictions must be considered when selecting E and F:

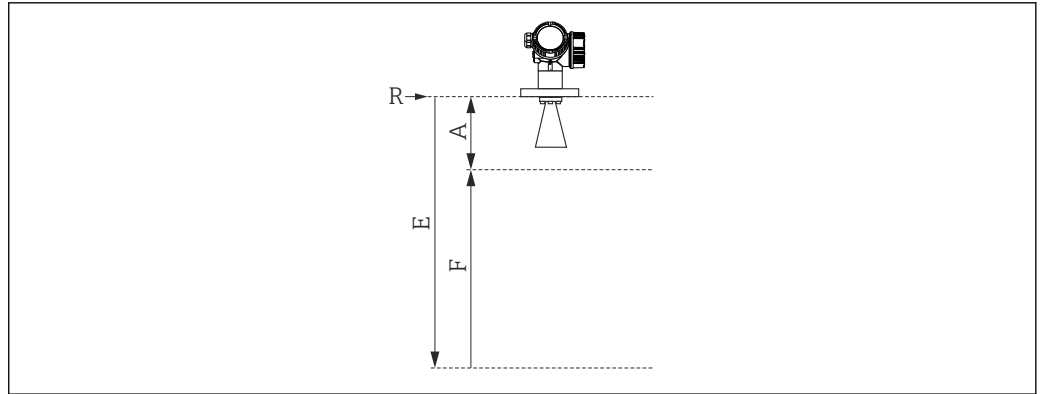

A0017983

Version	Minimum distance between reference point R and 100% mark	Minimum span	Maximum value for "Empty calibration"
FMR56/FMR57 Without antenna extension	$A \geq \text{length of antenna} + 600 \text{ mm (24 in)}^1$		
FMR57 with antenna extension <sup>2)</sup>	$A \geq \text{length of antenna} + \text{antenna extension} + 600 \text{ mm (24 in)}^3$	$F \geq 400 \text{ mm (16 in)}$	$E \leq 20 \text{ m (66 ft)}$

- 1) Minimum value for FMR57: 861 mm (16 in)
- 2) Feature 610 "Accessory mounted" option OP or OT
- 3) Minimum value: 861 mm (16 in)

**i** The linearity check is performed under reference operating conditions.

**i** The selected values for **Empty calibration** and **Full calibration** are only used to create the linearity protocol. Afterwards, the values are reset to the default values specific for the antenna. If values other than the default values are required, they must be ordered as a customized parameterization.

2) If (E) and (F) are not specified, antenna-dependent default values will be used instead.

**Customer-specific configuration**

If the option IJ: "Customized parameterization HART", IK "Customized parameterization PA" or IL "Customized parameterization FF" has been selected in feature 570 "Service", presettings that differ from the default settings can be selected for the following parameters:

Parameters	Communication protocol	Picklist / range of values
Setup → Unit of length	<ul style="list-style-type: none"> <li>■ HART</li> <li>■ PA</li> <li>■ FF</li> </ul>	<ul style="list-style-type: none"> <li>■ in</li> <li>■ ft</li> <li>■ mm</li> <li>■ m</li> </ul>
Setup → Empty calibration	<ul style="list-style-type: none"> <li>■ HART</li> <li>■ PA</li> <li>■ FF</li> </ul>	max. 70 m (230 ft)
Setup → Full calibration	<ul style="list-style-type: none"> <li>■ HART</li> <li>■ PA</li> <li>■ FF</li> </ul>	max. < 70 m (230 ft)
Setup → Extended setup → Curr. output 1/2 → Damping	HART	0 to 999.9 s
Setup → Extended setup → Curr. output 1/2 → Failure mode	HART	<ul style="list-style-type: none"> <li>■ Min</li> <li>■ Max</li> <li>■ Last valid value</li> </ul>
Expert → Comm. → HART config. → Burst mode	HART	<ul style="list-style-type: none"> <li>■ Off</li> <li>■ On</li> </ul>

**Tagging (TAG)**

<b>Ordering feature</b>	895: Marking
<b>Option</b>	Z1: Tagging (TAG), see additional spec.
<b>Position of the measuring point marking</b>	To be selected in the additional specifications: <ul style="list-style-type: none"> <li>■ Tag plate Stainless Steel</li> <li>■ Self-adhesive paper label</li> <li>■ Supplied label/plate</li> <li>■ RFID TAG</li> <li>■ RFID TAG + Tag plate Stainless Steel</li> <li>■ RFID TAG + Self-adhesive paper label</li> <li>■ RFID TAG + Supplied label/plate</li> </ul>
<b>Definition of the measuring point designation</b>	To be defined in the additional specifications: 3 lines containing up to 18 characters each  The measuring point designation appears on the selected label and/or the RFID TAG.
<b>Designation in the Electronic Name Plate (ENP)</b>	The first 32 characters of the measuring point designation
<b>Designation on the display module</b>	The first 12 characters of the measuring point designation

**Services**

The following services can be selected via the product structure in the Product Configurator:

- PWIS-free (PWIS = paint-wetting impairment substances)
- Customized parameterization HART
- Customized parameterization PA
- Customized parameterization FF
- W/o tooling DVD (FieldCare)
- Hard-copy product documentation



## Application packages

---

### Heartbeat Diagnostics

#### Availability

Available in all device versions.

#### Function

- Continuous self-monitoring of the device.
- Diagnostic messages output to
  - the local display.
  - an asset management system (e.g. FieldCare/DeviceCare).
  - an automation system (e.g. PLC).

#### Advantages

- Device condition information is available immediately and processed in time.
- The status signals are classified in accordance with VDI/VDE 2650 and NAMUR recommendation NE 107 and contain information about the cause of the error and remedial action.

#### Detailed description

See the "Diagnostics and troubleshooting" section of the Operating Instructions for the device.

## Heartbeat Verification

### Availability

Available for the following versions of feature 540 "Application package":

- EH: Heartbeat Verification + Monitoring
- EJ: Heartbeat Verification

### Device functionality checked on demand

- Verification of the correct functioning of the measuring device within specifications.
- The verification result provides information about the condition of the device: **Passed** or **Failed**.
- The results are documented in a verification report.
- The automatically generated report supports the obligation to demonstrate compliance with internal and external regulations, laws and standards.
- Verification is possible without interrupting the process.

### Advantages

- No onsite presence is required to use the function.
- The DTM<sup>3)</sup> triggers verification in the device and interprets the results. No specific knowledge is required on the part of the user.
- The verification report can be used to prove quality measures to a third party.
- **Heartbeat Verification** can replace other maintenance tasks (e.g. periodic check) or extend the test intervals.

### SIL/WHG-locked devices<sup>4)</sup>

- The **Heartbeat Verification** module contains a wizard for the proof test which must be performed at appropriate intervals for the following applications:
  - SIL (IEC61508/IEC61511)
  - WHG (German Water Resources Act)
- To perform a proof test, the device must be locked (SIL/WHG locking).
- The wizard can be used via FieldCare, DeviceCare or a DTM-based process control system.



In the case of SIL-locked and WHG-locked devices, it is **not** possible to perform verification without taking additional measures (e.g. bridging the output current) because the output current must be simulated (Increased safety mode) or the level must be approached manually (Expert mode) during subsequent re-locking (SIL/WHG locking).

### Detailed description



SD01871F

3) DTM: Device Type Manager; controls device operation via DeviceCare, FieldCare or a DTM-based process control system.

4) Only relevant for devices with SIL or WHG approval: order code 590 ("Additional approval"), option LA ("SIL") or LC ("WHG").

## Heartbeat Monitoring

### Availability

Available for the following versions of feature 540 "Application package":  
EH: Heartbeat Verification + Monitoring

### Function

- In addition to the verification parameters, the corresponding parameter values are also logged.
- Existing measured variables, such as the echo amplitude, are used in the **Foam detection** and **Build-up detection** wizards.

 In the Micropilot FMR6x, the **Foam detection** and **Build-up detection** wizards cannot be used together.

### "Foam detection" wizard

- The Heartbeat Monitoring module contains the **Foam detection** wizard.
- This wizard is used to configure automatic foam detection, which detects foam on the product surface on the basis of the reduced signal amplitude. Foam detection can be linked to a switch output in order to control a sprinkler system, for example, which dissolves the foam.
- This wizard can be used via FieldCare, DeviceCare or a DTM-based process control system.

### "Build-up detection" wizard

- The Heartbeat Monitoring module contains the **Build-up detection** wizard.
- The wizard is used to configure automatic buildup detection, which detects the buildup of deposits on the antenna on the basis of the increased area of the coupling signal. Buildup detection can be linked to a switch output in order to control a compressed air system, for example, to clean the antenna.
- This wizard can be used via FieldCare, DeviceCare or a DTM-based process control system.

### Advantages

- Early detection of changes (trends) to ensure plant availability and product quality.
- Use of information for the proactive planning of measures (e.g. cleaning/maintenance).
- Identification of undesirable process conditions as the basis to optimizing the facility and the processes.
- Automated control of measures to remove foam or buildup.

### Detailed description



 SD01871F

## Accessories

Device-specific accessories      Weather protection cover

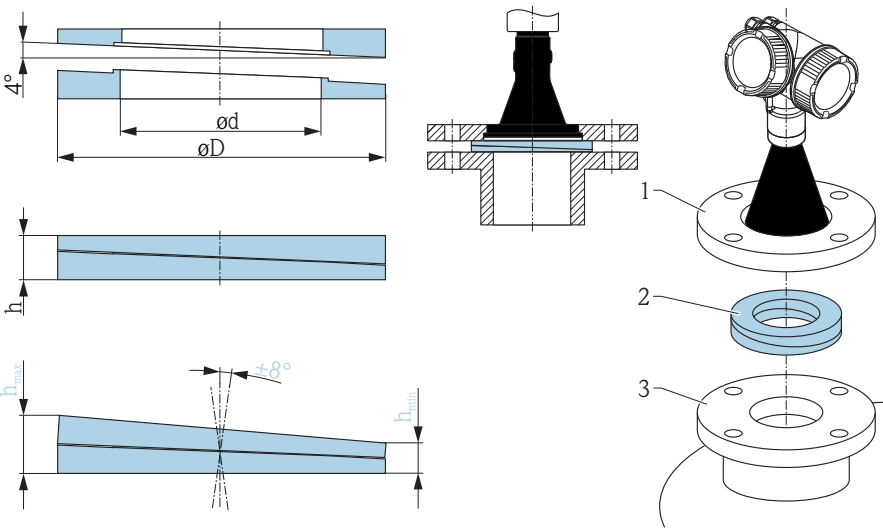

Accessory	Description
Weather protection cover	<p style="text-align: right;">A0015466</p> <p style="text-align: right;">A0015472</p> <p>49 Weather protection cover; Dimensions: mm (in)</p> <p> The weather protection cover can be ordered together with the device (product structure, feature 620 "Accessory Enclosed", option PB "Weather Protection Cover"). Alternatively, it can be separately ordered as an accessory; order code 71162242.</p>

Adjustable flange seal for FMR50/FMR56

Accessories	Description		
Adjustable flange seal for FMR50/FMR56	 <p data-bbox="414 873 670 952">                     1 UNI slip-on flange                      2 Adjustable flange seal                      3 Nozzle                 </p> <p data-bbox="414 974 1524 1041">  The material properties and process conditions of the adjustable flange seal must be compatible with the properties (temperature, pressure, resistance) of the process.                 </p> <p data-bbox="414 1041 1524 1097">  For FMR56: The adjustable flange seal can also be ordered directly with the device (product structure: feature 620 "Accessory enclosed", options PL, PM, PN, PO, PQ, PR).                 </p>		
<b>Technical data: version DN/JIS</b>			
Order number	71074263	71074264	71074265
Compatible with	DN80 PN10/40	DN100 PN10/16	<ul style="list-style-type: none"> <li>■ DN150 PN10/16</li> <li>■ JIS 10K 150A</li> </ul>
Recommended screw length	100 mm (3.9 in)	100 mm (3.9 in)	110 mm (4.3 in)
Recommended screw size	M14	M14	M18
Material	EPDM		
Process pressure	-0.1 to 0.1 bar (-1.45 to 1.45 psi)		
Process temperature	-40 to +80 °C (-40 to +176 °F)		
D	142 mm (5.59 in)	162 mm (6.38 in)	218 mm (8.58 in)
d	89 mm (3.5 in)	115 mm (4.53 in)	169 mm (6.65 in)
h	22 mm (0.87 in)	23.5 mm (0.93 in)	26.5 mm (1.04 in)
h <sub>min</sub>	14 mm (0.55 in)	14 mm (0.55 in)	14 mm (0.55 in)
h <sub>max</sub>	30 mm (1.18 in)	33 mm (1.3 in)	39 mm (1.45 in)

Accessories	Description			
	<b>Technical data: version ASME/JIS</b>			
Order number	71249070	71249072	71249073	
Compatible with	<ul style="list-style-type: none"> <li>▪ ASME 3" 150lbs</li> <li>▪ JIS 80A 10K</li> </ul>	ASME 4" 150lbs	ASME 6" 150lbs	
Recommended screw length	100 mm (3.9 in)	100 mm (3.9 in)	110 mm (4.3 in)	
Recommended screw size	M14	M14	M18	
Material	EPDM			
Process pressure	-0.1 to 0.1 bar (-1.45 to 1.45 psi)			
Process temperature	-40 to +80 °C (-40 to +176 °F)			
D	133 mm (5.2 in)	171 mm (6.7 in)	219 mm (8.6 in)	
d	89 mm (3.5 in)	115 mm (4.53 in)	168 mm (6.6 in)	
h	22 mm (0.87 in)	23.5 mm (0.93 in)	26.5 mm (1.04 in)	
h <sub>min</sub>	14 mm (0.55 in)	14 mm (0.55 in)	14 mm (0.55 in)	
h <sub>max</sub>	30 mm (1.18 in)	33 mm (1.3 in)	39 mm (1.45 in)	

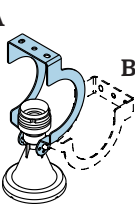
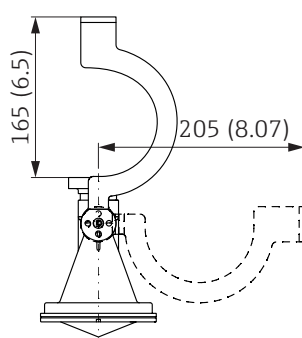
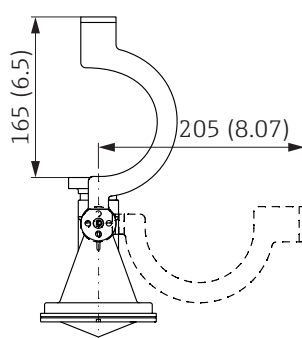
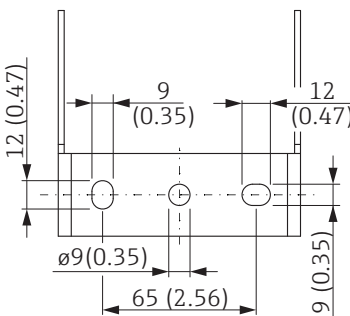
#### Mounting bracket for wall or ceiling mounting of FMR50/FMR56

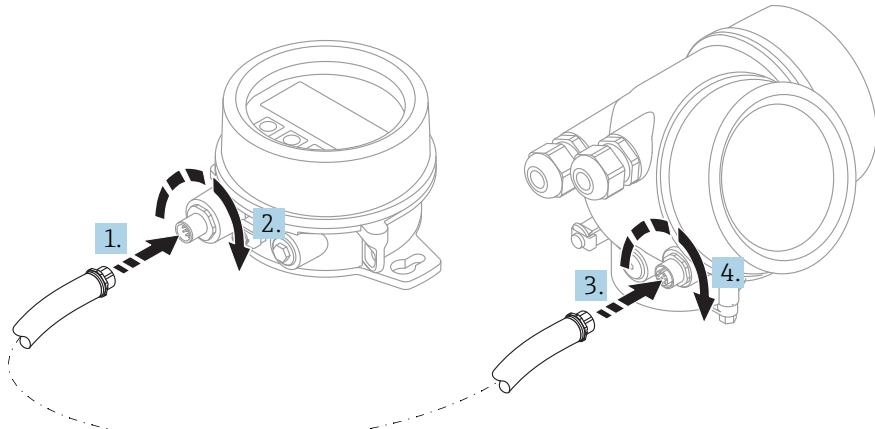

Accessories	Description
Mounting bracket for wall or ceiling mounting of FMR50/FMR56	<div style="display: flex; align-items: flex-start;"> <div style="margin-right: 20px;"> <p><b>A</b></p>  <p><b>B</b></p>  </div> <div style="margin-right: 20px;">  </div> <div>  </div> </div> <p style="text-align: right; font-size: small;">A0017746</p> <p> 50 Mounting bracket for FMR50/FMR56 with horn antenna</p> <p>A Ceiling installation B Wall mounting</p> <ul style="list-style-type: none"> <li>▪ <b>Material:</b> <ul style="list-style-type: none"> <li>▪ Mounting bracket: 304 (1.4301)</li> <li>▪ Screws: A2</li> <li>▪ Nordlock washers: A4</li> </ul> </li> <li>▪ <b>Order number:</b> 71162776</li> </ul>

Remote display FHX50

Accessories	Description
Remote display FHX50	<div style="text-align: center;">  </div> <p style="text-align: right; font-size: small;">A0019128</p> <ul style="list-style-type: none"> <li>▪ Material:             <ul style="list-style-type: none"> <li>▪ Plastic PBT</li> <li>▪ 316L/1.4404</li> <li>▪ Aluminum</li> </ul> </li> <li>▪ Degree of protection: IP68 / NEMA 6P and IP66 / NEMA 4x</li> <li>▪ Suitable for display modules:             <ul style="list-style-type: none"> <li>▪ SD02 (push buttons)</li> <li>▪ SD03 (touch control)</li> </ul> </li> <li>▪ Connecting cable:             <ul style="list-style-type: none"> <li>▪ Cable supplied with device up to 30 m (98 ft)</li> <li>▪ Standard cable supplied by customer up to 60 m (196 ft)</li> </ul> </li> <li>▪ Ambient temperature range: -40 to 80 °C (-40 to 176 °F)</li> <li>▪ Ambient temperature range (option): -50 to 80 °C (-58 to 176 °F) <sup>1)</sup></li> </ul> <p> <span style="font-size: small;">i</span> ▪ If the remote display should be used, order the device version "Prepared for display FHX50" (feature 030, version L, M or N). For the FHX50, you must select option A: "Prepared for display FHX50" under feature 050 "Measuring device version".         </p> <p> <span style="font-size: small;">i</span> ▪ If the device version "Prepared for display FHX50" was not originally ordered and a FHX50 display is to be retrofitted, you must select version B "Not prepared for display FHX50" under feature 050: "Measuring device version" when ordering the FHX50. In this case, a retrofit kit for the device is supplied with the FHX50. The kit can be used to prepare the device so that the FHX50 can be used.         </p> <p> <span style="font-size: small;">i</span> Use of the FHX50 may be restricted for transmitters with an approval. A device can only be retrofitted with the FHX50 if the option L, M or N ("Prepared for FHX50") is listed under <i>Basic specifications</i>, item 4 "Display, operation" in the Safety Instructions (XA) for the device.              Also pay attention to the Safety Instructions (XA) of the FHX50.         </p> <p> <span style="font-size: small;">i</span> Retrofitting is not possible on transmitters with:             <ul style="list-style-type: none"> <li>▪ An approval for use in areas with flammable dust (dust ignition-proof approval)</li> <li>▪ Ex nA type of protection</li> </ul> </p> <p> <span style="font-size: small;">i</span> For details, see document SD01007F.         </p>

1) This range is valid if option JN "Ambient temperature transmitter -50 °C (-58 °F)" has been selected in ordering feature 580 "Test, Certificate". If the temperature is permanently below -40 °C (-40 °F), failure rates may be increased.

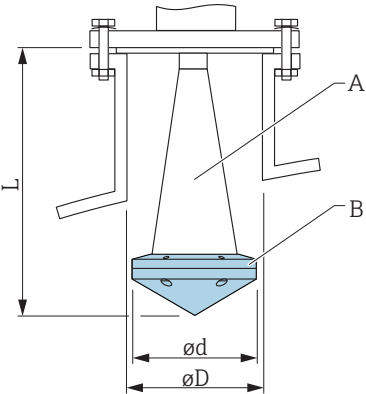
## Horn protection for horn antenna

Accessories	Description
Horn protection for horn antenna 80 mm (3 in) or 100 mm (4 in)	 <p>A0019143</p> <p>A Horn antenna of the Micropilot (not included in the delivery of the horn protection)  B Horn protection  <math>\varnothing d</math> Diameter of horn protection (see table below)  <math>\varnothing D</math> Minimum nozzle diameter (see table below)  L Length of antenna with horn protection (see table below)</p> <p>For details, see the Installation Instructions SD01084F.</p> <p><b>Process conditions</b></p> <ul style="list-style-type: none"> <li>Maximum vessel pressure: 0.5 bar (7.252 psi)</li> <li>Maximum process temperature: 130 °C (266 °F)</li> </ul> <p> Explosion Hazard  Avoid electrostatic charge of the horn protection.</p>

## Horn protection for FMR57

Antenna <sup>1)</sup>	Order number for horn protection	Dimensions of antenna + horn protection		
		L	$\varnothing d$	$\varnothing D$
BC: horn 80mm/3"	71105890	238 mm (9.4 in)	96 mm (3.78 in)	≥ DN100
BD: horn 100mm/4"	71105889	450 mm (17.7 in)	116 mm (4.57 in)	≥ DN150

1) Feature 070 in the product structure

 The horn protection can also be ordered together with the device. Product structure: feature 610 "Accessory mounted", option OW "Horn protection, PTFE".

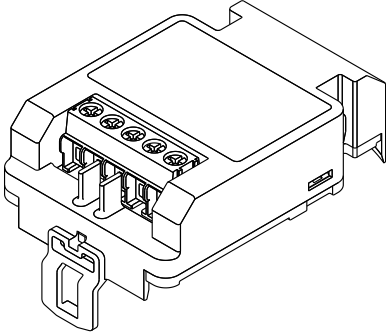

Overvoltage protection

Accessory	Description
<p>Overvoltage protection for 2-wire-devices                      OVP10 (1 channel)                      OVP20 (2 channel)</p>	<div style="text-align: right; font-size: small;">A0021734</div>  <p><b>Technical data</b></p> <ul style="list-style-type: none"> <li>▪ Resistance per channel: <math>2 * 0.5 \Omega_{max}</math></li> <li>▪ Threshold DC voltage: 400 to 700 V</li> <li>▪ Threshold impulse voltage: &lt; 800 V</li> <li>▪ Capacitance at 1 MHz: &lt; 1.5 pF</li> <li>▪ Nominal arrest impulse voltage (8/20 <math>\mu</math>s): 10 kA</li> <li>▪ Suited for wire cross-sections: 0.2 to 2.5 mm<sup>2</sup> (24 to 14 AWG)</li> </ul> <p><b>i</b> <b>Ordering with device</b>                      The overvoltage protection module is preferably ordered with the device. See product structure, feature 610 "Accessory mounted", option NA "Overvoltage protection". Separate ordering of the module is only necessary if a device is to be retrofitted with the overvoltage protection.</p> <p><b>i</b> <b>Order code for retrofitting</b></p> <ul style="list-style-type: none"> <li>▪ For 1-channel devices (feature 020, option A)                          OVP10: 71128617</li> <li>▪ For 2-channel devices (feature 020, option B, C, E or G)                          OVP20 : 71128619</li> </ul> <p><b>Housing lid for retrofitting</b>                      In order to keep the necessary safety distances, the housing lid needs to be replaced if the device is retrofitted with the overvoltage protection. Depending on the housing type, the order code of the suitable lid is as follows:</p> <ul style="list-style-type: none"> <li>▪ GT18 housing: Lid 71185516</li> <li>▪ GT19 housing: Lid 71185518</li> <li>▪ GT20 housing: Lid 71185516</li> </ul> <p><b>i</b> <b>Restrictions for retrofitting</b>                      Depending on the approval of the transmitter the usage of the OVP module may be restricted. A device may only be retrofitted with an OVP module if the option NA (overvoltage protection) is quoted under <i>Optional Specifications</i> in the Safety Instructions (XA) pertaining to the device.</p> <p><b>i</b> For details refer to SD01090F.</p>

## Bluetooth module for HART devices

Accessory	Description
Bluetooth module	<div data-bbox="327 315 973 761" data-label="Image"> </div> <div data-bbox="1380 768 1437 784" data-label="Text">A0036493</div> <ul style="list-style-type: none"> <li>▪ Quick and easy commissioning via SmartBlue (app)</li> <li>▪ No additional tools or adapters required</li> <li>▪ Signal curve via SmartBlue (app)</li> <li>▪ Encrypted single point-to-point data transmission (tested by Fraunhofer institute) and password protected communication via Bluetooth® wireless technology</li> <li>▪ Range under reference conditions: &gt; 10 m (33 ft)</li> </ul> <p><b>i</b> When using the Bluetooth module the minimum supply voltage increases by up to 3 V.</p> <p><b>i</b> <b>Ordering with device</b> The Bluetooth module is preferably ordered with the device. See product structure, feature 610 "Accessory Mounted", option NF "Bluetooth". A separate order is only necessary in case of retrofitting.</p> <p><b>i</b> <b>Order code for retrofitting</b> Bluetooth module (BT10): 71377355</p> <p><b>i</b> <b>Restrictions in case of retrofitting</b> Depending on the approval of the transmitter, application of the Bluetooth module may be restricted. A device may only be retrofitted with a Bluetooth module if the option <i>NF</i> (Bluetooth) is listed in the associated Safety Instructions (XA) under <i>Optional specifications</i>.</p> <p><b>i</b> For details refer to SD02252F.</p>

**Communication-specific accessories****Commubox FXA195 HART**

For intrinsically safe HART communication with FieldCare via the USB interface



For details, see "Technical Information" TI00404F

**Commubox FXA291**

Connects Endress+Hauser field devices with a CDI interface (= Endress+Hauser Common Data Interface) and the USB port of a computer or laptop

Order number: 51516983



For details, see "Technical Information" TI00405C

**HART Loop Converter HMX50**

Is used to evaluate and convert dynamic HART process variables to analog current signals or limit values

Order number: 71063562



For details, see "Technical Information" TI00429F and Operating Instructions BA00371F

**WirelessHART adapter SWA70**

- Is used for the wireless connection of field devices
- The WirelessHART adapter can be easily integrated into field devices and existing infrastructures, offers data protection and transmission safety and can be operated in parallel with other wireless networks



For details, see Operating Instructions BA00061S

**Connect Sensor FXA30/FXA30B**

Fully integrated, battery-powered gateway for simple applications with SupplyCare Hosting. Up to 4 field devices with 4 to 20 mA communication (FXA30/FXA30B), serial Modbus (FXA30B) or HART (FXA30B) can be connected. With its robust design and ability to run for years on the battery, it is ideal for remote monitoring in isolated locations. Version with LTE (USA, Canada and Mexico only) or 3G mobile transmission for worldwide communication.



For details, see "Technical Information" TI01356S and Operating Instructions BA01710S.

**Fieldgate FXA42**

Fieldgates enable communication between connected 4 to 20 mA, Modbus RS485 and Modbus TCP devices and SupplyCare Hosting or SupplyCare Enterprise. The signals are transmitted either via Ethernet TCP/IP, WLAN or mobile communications (UMTS). Advanced automation capabilities are available, such as an integrated Web-PLC, OpenVPN and other functions.



For details, see "Technical Information" TI01297S and Operating Instructions BA01778S.

**SupplyCare Enterprise SCE30B**

Inventory management software that displays the level, volume, mass, temperature, pressure, density or other parameters of tanks. The parameters are recorded and transmitted by means of gateways like Fieldgate FXA42, Connect Sensor FXA30B or other gateway types. This Web-based software is installed on a local server and can also be visualized and operated with mobile terminals such as a smartphone or tablet.



For details, see Technical Information TI01228S and Operating Instructions BA00055S

**SupplyCare Hosting SCH30**

Inventory management software that displays the level, volume, mass, temperature, pressure, density or other parameters of tanks. The parameters are recorded and transmitted by means of gateways like Fieldgate FXA42, Connect Sensor FXA30B or other gateway types. SupplyCare Hosting is offered as a hosting service (Software as a Service, SaaS). In the Endress+Hauser portal, the user is provided with the data over the Internet.



For details, see Technical Information TI01229S and Operating Instructions BA00050S

**Field Xpert SFX350**

Field Xpert SFX350 is a mobile computer for commissioning and maintenance. It enables efficient device configuration and diagnostics for HART and FOUNDATION Fieldbus devices in the **non-Ex area**.



For details, see Operating Instructions BA01202S

**Field Xpert SFX370**

Field Xpert SFX370 is a mobile computer for commissioning and maintenance. It enables efficient device configuration and diagnostics for HART and FOUNDATION Fieldbus devices in the **non-Ex area** and the **Ex area**.



For details, see Operating Instructions BA01202S

**Service-specific accessories****DeviceCare SFE100**

Configuration tool for HART, PROFIBUS and FOUNDATION Fieldbus field devices



Technical Information TI01134S

**FieldCare SFE500**

FDT-based plant asset management tool

It can configure all smart field units in your system and helps you manage them. By using the status information, it is also a simple but effective way of checking their status and condition.



Technical Information TI00028S

**System components****Memograph M graphic data manager**

The Memograph M graphic data manager provides information on all the relevant process variables. Measured values are recorded correctly, limit values are monitored and measuring points analyzed. The data are stored in the 256 MB internal memory and also on a SD card or USB stick.



Technical Information TI00133R and Operating Instructions BA00247R

**RN221N**

Active barrier with power supply for safe separation of 4 to 20 mA standard signal circuits. Offers bidirectional HART transmission.



Technical Information TI00073R and Operating Instructions BA00202R

**RN221**

Supply unit for powering two 2-wire measuring devices solely in the non-Ex area. Bidirectional communication is possible via the HART communication jacks.



Technical Information TI00081R and Brief Operating Instructions KA00110R

## Supplementary documentation

The following documentation types are available in the Downloads section of the Endress+Hauser website ([www.endress.com/downloads](http://www.endress.com/downloads)):



For an overview of the scope of the associated Technical Documentation, refer to the following:

- *W@M Device Viewer* ([www.endress.com/deviceviewer](http://www.endress.com/deviceviewer)): Enter the serial number from nameplate
- *Endress+Hauser Operations App*: Enter the serial number from the nameplate or scan the 2D matrix code (QR code) on the nameplate

**Brief Operating Instructions (KA)****Guide that takes you quickly to the 1st measured value**

The Brief Operating Instructions contain all the essential information from incoming acceptance to initial commissioning.

**Operating Instructions (BA)****Your reference guide**

These Operating Instructions contain all the information that is required in various phases of the life cycle of the device: from product identification, incoming acceptance and storage, to mounting, connection, operation and commissioning through to troubleshooting, maintenance and disposal.

**Safety Instructions (XA)**

Depending on the approval, the following Safety Instructions (XA) are supplied with the device. They are an integral part of the Operating Instructions.



The nameplate indicates the Safety Instructions (XA) that are relevant to the device.

---



71486058

[www.addresses.endress.com](http://www.addresses.endress.com)

---