

# Technical Information

## Micropilot FMR20

### Modbus RS485

Free space radar  
For bulk solids

#### Level measurement for bulk solids

##### Application

- Ingress protection: IP66/68 / NEMA 4X/6P
- Maximum measuring range up to 10 m (32.8 ft)
- Process temperature: -40 to 80 °C (-40 to 176 °F)
- Accuracy: up to ± 5 mm (0.2 in)

##### Your benefits

- Level measurement for solids
- Simple, safe and secure wireless remote access – ideal for installation in places difficult to reach
- Commissioning, operation and maintenance via free iOS / Android app SmartBlue – saves time and reduces costs
- Hermetically sealed wiring and fully potted electronics – eliminate dust ingress and allow operation under harsh environmental conditions



## Table of contents









<b>Important document information</b> . . . . .	<b>3</b>	Storage temperature . . . . .	22
Symbols used . . . . .	3	Climate class . . . . .	22
<b>Terms and abbreviations</b> . . . . .	<b>4</b>	Operating altitude as per IEC 61010-1 Ed.3 . . . . .	22
<b>Product life cycle</b> . . . . .	<b>5</b>	Degree of protection . . . . .	22
Engineering . . . . .	5	Vibration resistance . . . . .	22
Procurement . . . . .	5	Electromagnetic compatibility (EMC) . . . . .	22
Installation . . . . .	5	<b>Process</b> . . . . .	<b>23</b>
Commissioning . . . . .	5	Process temperature, process pressure . . . . .	23
Operation . . . . .	5	Dielectric constant . . . . .	23
Maintenance . . . . .	5	<b>Mechanical construction</b> . . . . .	<b>24</b>
Retirement . . . . .	5	Dimensions . . . . .	24
<b>Measuring principle</b> . . . . .	<b>6</b>	Weight . . . . .	27
Input . . . . .	6	Materials . . . . .	28
Output . . . . .	6	Connecting cable . . . . .	28
<b>Input</b> . . . . .	<b>6</b>	<b>Operability</b> . . . . .	<b>28</b>
Measured variable . . . . .	6	Operating concept . . . . .	28
Measuring range . . . . .	6	Operation via Bluetooth® wireless technology . . . . .	28
Operating frequency . . . . .	7	Remote operation via Modbus protocol . . . . .	29
Transmission power . . . . .	7	<b>Certificates and approvals</b> . . . . .	<b>30</b>
<b>Output</b> . . . . .	<b>7</b>	CE mark . . . . .	30
Digital output . . . . .	7	RoHS . . . . .	30
Signal on alarm . . . . .	7	EAC conformity . . . . .	30
Linearization . . . . .	7	RCM marking . . . . .	30
<b>Protocol-specific data, Modbus</b> . . . . .	<b>8</b>	Approvals . . . . .	30
Modbus settings . . . . .	8	Explosion-protected smartphones and tablets . . . . .	30
Measured variables via Modbus protocol . . . . .	8	Pressure equipment with allowable pressure	
<b>Electrical connection</b> . . . . .	<b>9</b>	≤ 200 bar (2 900 psi) . . . . .	30
Cable assignment . . . . .	9	EN 302729-1/2 radio standard . . . . .	30
Supply voltage . . . . .	9	FCC / Industry Canada . . . . .	31
Power consumption . . . . .	9	Mexico . . . . .	32
Starting time . . . . .	11	Other standards and guidelines . . . . .	33
Power supply failure . . . . .	11	<b>Ordering information</b> . . . . .	<b>33</b>
Connecting the device . . . . .	11	<b>Accessories</b> . . . . .	<b>34</b>
Cable specification . . . . .	13	Device-specific accessories . . . . .	34
Overvoltage protection . . . . .	13	Service-specific accessories . . . . .	48
<b>Performance characteristics</b> . . . . .	<b>13</b>	<b>Supplementary documentation</b> . . . . .	<b>48</b>
Reference operating conditions . . . . .	13	Brief Operating Instructions (KA) . . . . .	48
Maximum measured error . . . . .	13	Operating Instructions (BA) . . . . .	48
Measured value resolution . . . . .	13	Safety Instructions (XA) . . . . .	48
Response time . . . . .	14	<b>Registered trademarks</b> . . . . .	<b>49</b>
Influence of ambient temperature . . . . .	14		
<b>Installation</b> . . . . .	<b>14</b>		
Installation conditions . . . . .	14		
<b>Environment</b> . . . . .	<b>22</b>		
Ambient temperature range . . . . .	22		

## Important document information

---

### Symbols used

### Symbols for certain types of information and graphics

-  **Permitted**  
Procedures, processes or actions that are permitted
-  **Forbidden**  
Procedures, processes or actions that are forbidden
-  **Tip**  
Indicates additional information
-  **Reference to documentation**
-  **Reference to graphic**
-  **Notice or individual step to be observed**
-  **1, 2, 3**  
Series of steps
-  **Result of a step**
- 1, 2, 3, ...**  
Item numbers
- A, B, C, ...**  
Views

## Terms and abbreviations

**BA**

Document type "Operating Instructions"

**KA**

Document type "Brief Operating Instructions"

**TI**

Document type "Technical Information"

**SD**

Document type "Special Documentation"

**XA**

Document type "Safety Instructions"

**PN**

Nominal pressure

**MWP**

MWP (Maximum working pressure/max. process pressure)

The MWP can also be found on the nameplate.

**ToF**

Time of Flight

 **$\epsilon_r$  (Dk value)**

Relative dielectric constant

**Operating tool**

The term "operating tool" is used in place of the following operating software: SmartBlue (app), for operation using an Android or iOS smartphone or tablet

**RTU**

Remote Transmit Unit

**BD**

Blocking Distance; no signals are analyzed within the BD.

**PLC**

Programmable logic controller (PLC)

**CDI**

Common Data Interface

## Product life cycle

---

### Engineering

- Proven radar measuring technology
  - Wide range of installation possibilities and accessories
  - Highest degree of ingress protection
  - 2D/3D drawings
  - Spec Sheet Producer
  - Applicator selection tool for selecting the perfect measurement solution
-  Device not compatible with transmitters and sensors that use ultrasonic measurement technology (e.g. Prosonic FMU9x, FDU9x)
- 

### Procurement

- Global availability
  - Order code includes variety of mounting accessories
- 

### Installation

- Rear thread for flexible installation
  - Slip-on flange for nozzle installation
  - Complete measuring point: including mounting accessory and flooding protection tube
- 

### Commissioning

- Quick and easy setup with SmartBlue (app) and Modbus
  - No additional tools or adapters required
  - Local languages (up to 15)
- 

### Operation

- Continuous self-monitoring
  - Diagnostics information according to NAMUR NE107 with remedial measures in the form of plain text messages
  - Signal curve via SmartBlue (app)
  - Encrypted single point-to-point data transmission (tested by Fraunhofer AISEC) and password-protected communication via Bluetooth® wireless technology
- 

### Maintenance

- No maintenance required
  - Technical experts on call around the world
- 

### Retirement

- Environmentally responsible recycling concepts
  - RoHS compliance (restriction of certain hazardous substances), lead-free soldering of electronic components
-

## Measuring principle

The Micropilot is a "downward-looking" measuring system that functions according to the time-of-flight (ToF) method. It measures the distance from the reference point **R** to the product surface. Radar impulses are emitted by an antenna, reflected off the product surface and received again by the radar system.

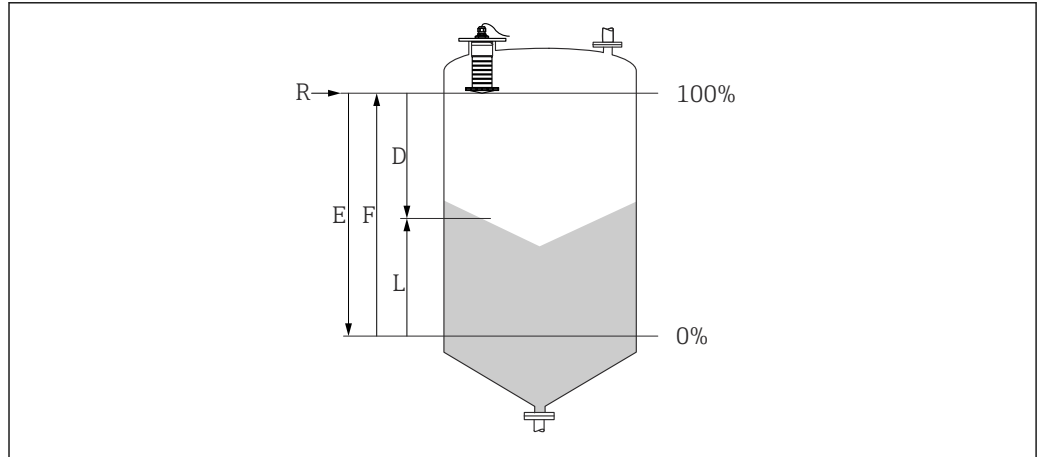

A0045303

1 Setup parameters of the Micropilot

- R* Reference point of the measurement (lower edge of the flange or threaded connection)
- E* Empty calibration (= zero)
- F* Full calibration (= span)
- D* Measured distance
- L* Level ( $L = E - D$ )

### Input

The reflected radar pulses are received by the antenna and transmitted to the electronics. A microprocessor evaluates the signals and identifies the level echo caused by the reflection of the radar pulses at the product surface. This clear signal detection system benefits from over 30 years' experience with time-of-flight procedures.

The distance **D** to the product surface is proportional to the time of flight **t** of the pulse:

$$D = c \cdot t / 2,$$

where **c** is the speed of light.

Based on the known empty distance **E**, the level **L** is calculated:

$$L = E - D$$

### Output

The device is adjusted by entering the empty distance **E** (= zero point) and the full distance **F** (= span).

Digital output (SmartBlue): 0 to 10 m (0 to 32.8 ft)

## Input

### Measured variable

The measured variable is the distance between the reference point and the product surface.

The level is calculated based on **E**, the empty distance entered.

### Measuring range

#### Maximum measuring range

10 m (32.8 ft)

### Installation requirements

- No agitators
- No buildup
- Relative dielectric constant  $\epsilon_r > 2$   
Contact Endress+Hauser for lower  $\epsilon_r$  values

### Usable measuring range

The usable measuring range depends on the medium's reflective properties, the installation position and any possible interference reflections.

Optimum results are achieved with coarse-grained material and the use of the flooding protection tube.

Reduction of the max. possible measuring range by:

- Media with bad reflective properties (= low  $\epsilon_r$  value)
- Product cone
- Extremely loose surfaces of bulk solids, e.g. bulk solids with low bulk weight in the case of pneumatic filling.
- Formation of buildup, particularly of moist products.

 For dielectric constants (DC values) of many media commonly used in various industries refer to:

- the Endress+Hauser DC manual (CP01076F)
- the Endress+Hauser "DC Values App" (available for Android and iOS)

---

**Operating frequency** K-band (~ 26 GHz)

---

**Transmission power** **Mean power density in the direction of the beam**

- At a distance of 1 m (3.3 ft): < 12 nW/cm<sup>2</sup>
- At a distance of 5 m (16 ft): < 0.4 nW/cm<sup>2</sup>

## Output

---

**Digital output**

**Modbus®**

Dedicated differential Modbus interface via separate wire pair

**Bluetooth® wireless technology**

The device has a *Bluetooth®* wireless technology interface and can be operated and configured via this interface using the SmartBlue app.

- The range under reference conditions is 25 m (82 ft)
- Incorrect operation by unauthorized persons is prevented by means of encrypted communication and password encryption
- The *Bluetooth®* wireless technology interface can be deactivated

---

**Signal on alarm**

Depending on the interface, failure information is displayed as follows:

- Digital communication (Modbus)
  - Status signal (as per NAMUR Recommendation NE 107)
  - Diagnostic code
- Operating tool via SmartBlue (app)
  - Status signal (as per NAMUR Recommendation NE 107)
  - Plain text display with remedial action

---

**Linearization**

The linearization function of the device allows the conversion of the measured value into any unit of length, weight, flow or volume. When operating via Modbus, linearization tables are pre-programmed for the calculation of the volume in vessels (see the following list).

**Pre-programmed linearization curves**

- Cylindrical tank
- Spherical tank
- Tank with pyramid bottom
- Tank with conical bottom
- Tank with flat bottom

Other linearization tables of up to 32 value pairs can be entered manually.

## Protocol-specific data, Modbus

**Modbus conformity**

Modbus-compliant with restrictions.

The TIA-485 Standard is only met with the following restrictions:

**Maximum bus load:**

100 Ω

For installations with a bus cable > 100 m, the load should not drop below 200 Ω, or a fieldbus repeater should be used.

**Time for connection setup**

< 1 s

**Addressing**

1 to 200

**Modbus settings**

The following settings can be customized via Bluetooth and Modbus.

Setting	Options	Default
Data bits	7,8	8
Parity	Even, odd, none	Even
Stop bits	1,2	1
Baud rate	1200, 2400, 4800, 9600, 19200	9600
Protocol	RTU, ASCII	RTU
Addressing	1 to 200	200
Minimum polling interval	500 ms	

**Measured variables via Modbus protocol**

The 8 most important process parameters are mapped as burst parameters to the first addresses in the Modbus address range. This means that these parameters can be read out in one measurement transmission. All parameters are available in the Float32 format.



The register address must be incremented by one (register address +1) when using the Memograph M RSG45 or Fieldgate FXA30b Modbus master. This can also apply for other masters.

Modbus address	Parameter name	Description	SI unit
5000	MODB_PV_VALUE	Level linearized (PV)	Depends on the type of linearization
5002	MODB_SV_VALUE	Distance (SV)	m
5004	MODB_TV_VALUE	Relative echo amplitude (TV)	dB
5006	MODB_QV_VALUE	Temperature (QV)	°C
5008	MODB_SIGNALQUALITY	Signal quality	-
5010	MODB_ACTUALDIAGNOSTICS	Current diagnostics number	-



Modbus address	Parameter name	Description	SI unit
5012	MODB_LOCATION_LONGITUDE	Longitude coordinate	°
5014	MODB_LOCATION_LATITUDE	Latitude coordinate	°

## Electrical connection

### Cable assignment

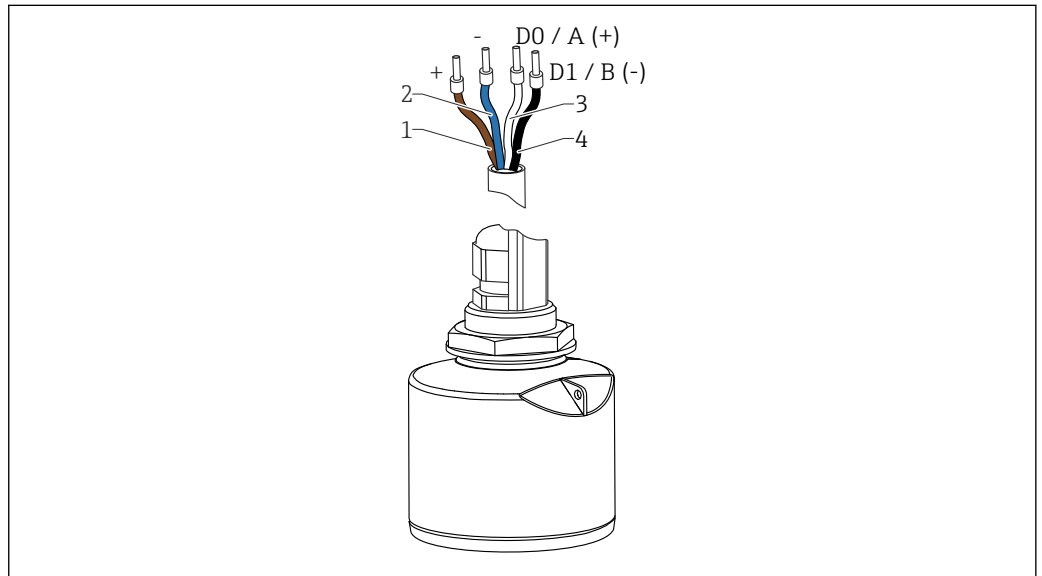

 2 FMR20 cable assignment, Modbus

- 1 Plus, brown wire
- 2 Minus, blue wire
- 3 Modbus DO/A (+), white wire
- 4 Modbus D1/B (-), black wire

### Supply voltage

5 to 30 V<sub>DC</sub>

An external power supply is necessary.

#### Battery operation

The sensor's Bluetooth® wireless technology communication can be disabled to increase the operating life of the battery.

#### Potential equalization

No special measures for potential equalization are required.

 Various power supply units can be ordered as an accessory from Endress+Hauser.

### Power consumption

Data with supply voltage 24 V<sub>DC</sub>

Maximum input power: 100 mW

Calculation for other supply voltage:

$$P = 39 \text{ mW} + (V_{CC} - 24 \text{ V}_{DC}) \times 0.28$$

Measures to reduce power consumption:

Disabling the Bluetooth® wireless technology interface reduces the power consumption by 1.5 mW.

**Single shot mode switched on/off via RTU**

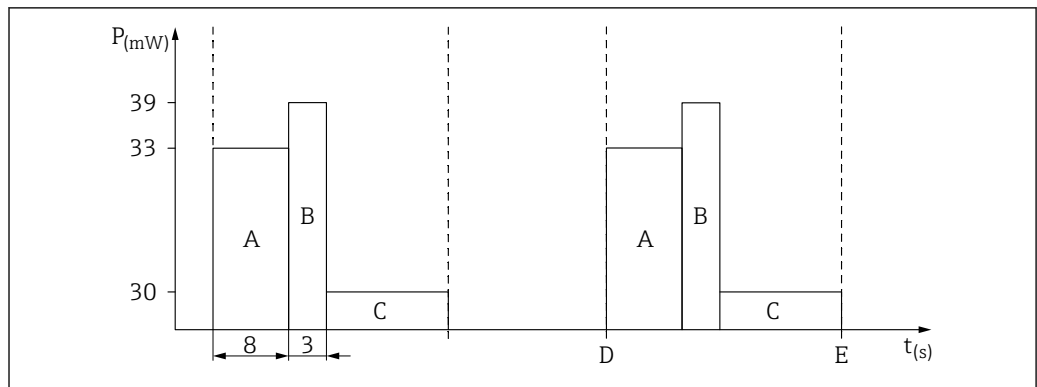

A0038152

3 Power consumption of single shot mode switched on/off via RTU

- A Start-up
- B Measurement
- C Power save mode
- D Switch on power supply
- E Switch off power supply

**Single shot mode switched on permanently**

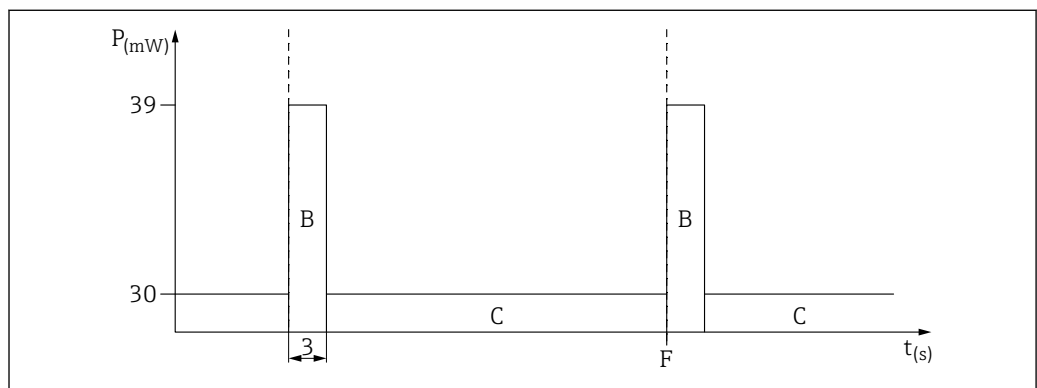

A0038151

4 Power consumption of single shot mode switched on permanently

- B Measurement
- C Power save mode
- F Trigger

**Continuous measuring mode switched on/off via RTU**

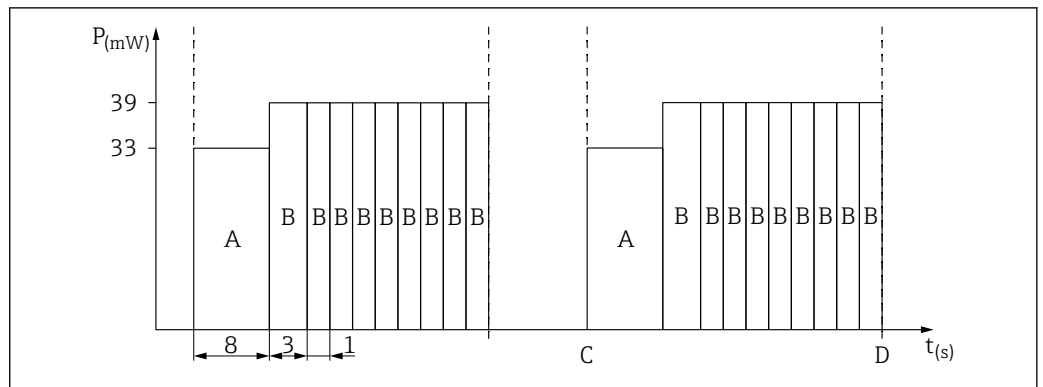

5 Power consumption of continuous measuring mode switched on/off via RTU

- A Start-up
- B Measurement
- C Switch on power supply
- D Switch off power supply

**Calculation example**

Assumed configuration

- RTU: E+H FXA30B with battery (7.2 V, 14.5 Ah)
- Modbus: single-shot mode switched on/off via RTU
- Switch on power supply every 15 min and leave switched on for 30 s

Power consumption with  $V_{cc} = 7.2 V$

- Start-up:  $33 mW + (7.2 V - 24 V) \times 0.28 = 28.3 mW$
- Measurement:  $39 mW + (7.2 V - 24 V) \times 0.28 = 34.3 mW$
- Power save mode:  $30 mW + (7.2 V - 24 V) \times 0.28 = 25.3 mW$

Energy of a measurement:

$$E = 8 s \times 28.3 mW + 3 s \times 34.3 mW + (30 s - 8 s - 3 s) \times 25.3 mW = 810 mWs$$

Number of measurements:

$$7.2 V \times 14.5 Ah \times 3600 / 0.810 Ws = \sim 460\,000 \text{ measurements}$$

Operating life:

$$460\,000 \times 15 \text{ min} = 4\,790 \text{ days} = 13 \text{ years}$$

 The energy consumption of the RTU is not taken into consideration!

**Starting time**

Until the 1st measured value:

- 11 s (typically)
- 15 s (maximum)

Until full accuracy:

- 15 s (typically)
- 20 s (maximum)

**Power supply failure**

The configuration remains stored in the sensor.

**Connecting the device**

**Block circuit diagram for Modbus RS485 connection**

The RS485 connection meets the requirements of the RS485-IS specification for use in hazardous environments.

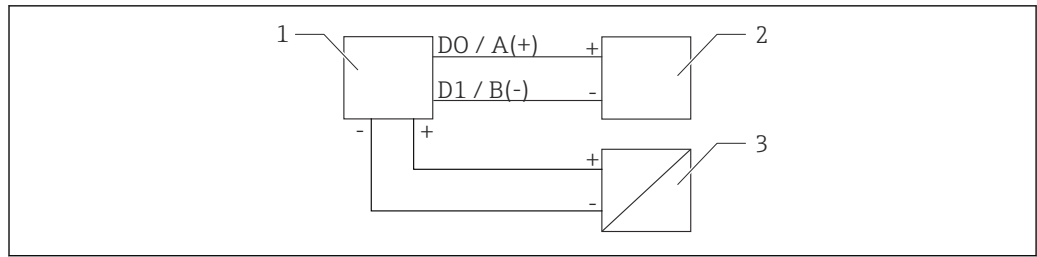

A0037751

6 Block circuit diagram for Modbus RS485 connection

- 1 Device with Modbus communication
- 2 Modbus master/RTU
- 3 Power supply

Up to 32 users can be connected on the RS485 bus.

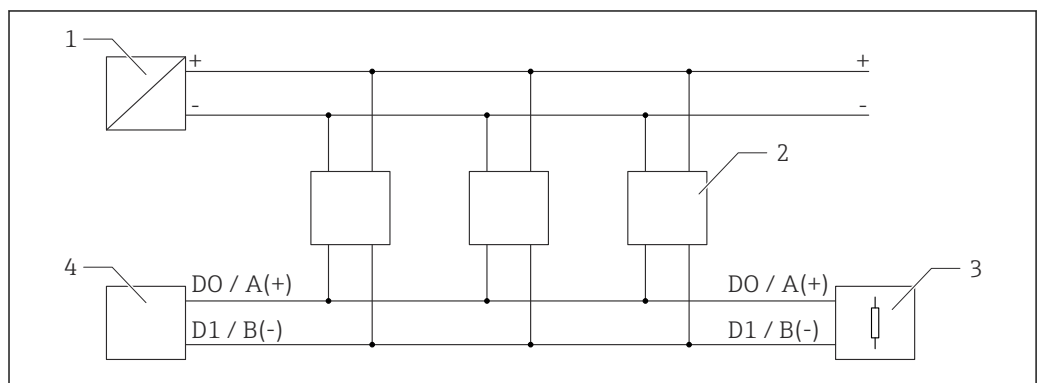

A0038149

7 Block circuit diagram for Modbus RS485 connection, multiple users

- 1 Power supply
- 2 Device with Modbus communication
- 3 Bus termination
- 4 Modbus master/RTU

**i** The bus cable should be a type-A fieldbus cable with a maximum length of 1200 m (3937 ft).

If the device is installed in a hazardous environment, the cable length may not exceed 1000 m (3281 ft).

A terminating resistor must be connected at both ends of the RS485 bus.

### Modbus RS485 bus terminating resistor

The bus terminating resistor should be installed as per the RS485-IS specification.

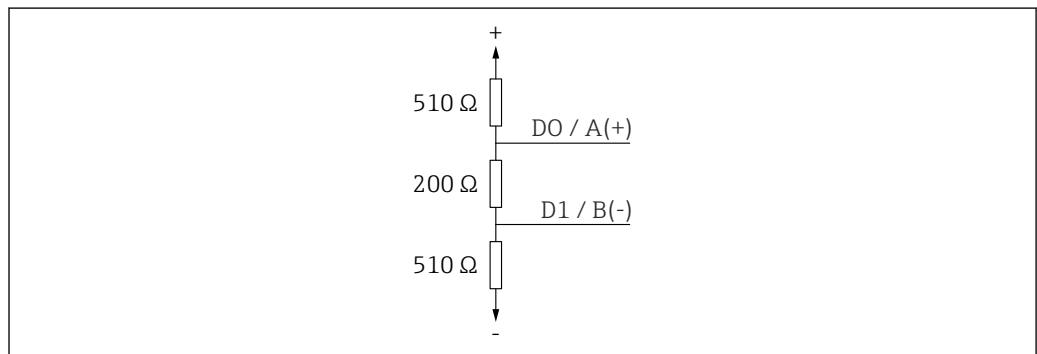

A0038150

8 Representation of the bus terminating resistor as per the RS485-IS specification

**Cable specification**

Unshielded cable, wire cross-section 0.22 mm<sup>2</sup>

- UV- and weather-resistant
- Flame resistance according to IEC 60332-1-2

As per IEC/EN 60079-11 section 10.9, the cable is designed for a tensile strength of 30 N (6.74 lbf) (over a period of 1 h).

The device is supplied with 5 m (16 ft) cable length as standard. Cable lengths 10 m (33 ft) and 20 m (66 ft) are optionally available.

User-defined lengths up to total length of 300 m (980 ft) are possible in increments of one meter or one foot.

**Overvoltage protection**

The device is equipped with integrated overvoltage protection.

## Performance characteristics

**Reference operating conditions**

- Temperature = +24 °C (+75 °F) ±5 °C (±9 °F)
- Pressure = 960 mbar abs. (14 psia) ±100 mbar (±1.45 psi)
- Humidity = 60 % ±15 %
- Reflector: metal plate with diameter ≥ 1 m (40 in)
- No major interference reflections inside the signal beam

**Maximum measured error**

Typical data under reference operating conditions: DIN EN 61298-2, percentage values in relation to the span.

**Output, digital; Modbus, SmartBlue (app)**

- Sum of non-linearity, non-repeatability and hysteresis: ±5 mm (±0.2 in)
- Offset/zero point: ±4 mm (±0.16 in)

**Differing values in near-range applications**

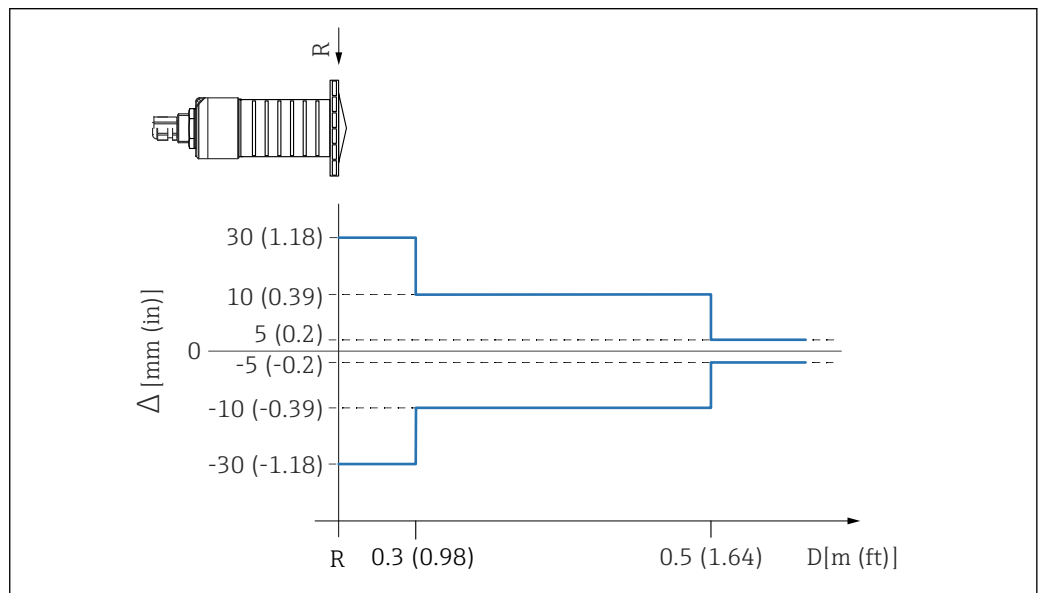

9 Maximum measured error in near-range applications; values for standard version

- Δ Maximum measured error
- R Reference point of the distance measurement
- D Distance from reference point of antenna

**Measured value resolution**

Dead band as per EN61298-2:  
 Digital: 1 mm (0.04 in)

**Response time**

The response time can be configured. The following step response times apply (in accordance with DIN EN 61298-2) when damping is switched off:

**Tank height**

<10 m (32.8 ft)

**Sampling rate**

1 s<sup>-1</sup>

**Response time**

<3 s

**i** In accordance with DIN EN 61298-2, the step response time is the time following an abrupt change in the input signal up until the changed output signal has adopted 90% of the steady-state value for the first time.

**Influence of ambient temperature**

The measurements are carried out in accordance with EN 61298-3.

Digital (Modbus, *Bluetooth*<sup>®</sup> wireless technology):

Standard version: average  $T_C = \pm 3 \text{ mm}$  ( $\pm 0.12 \text{ in}$ )/10 K

## Installation

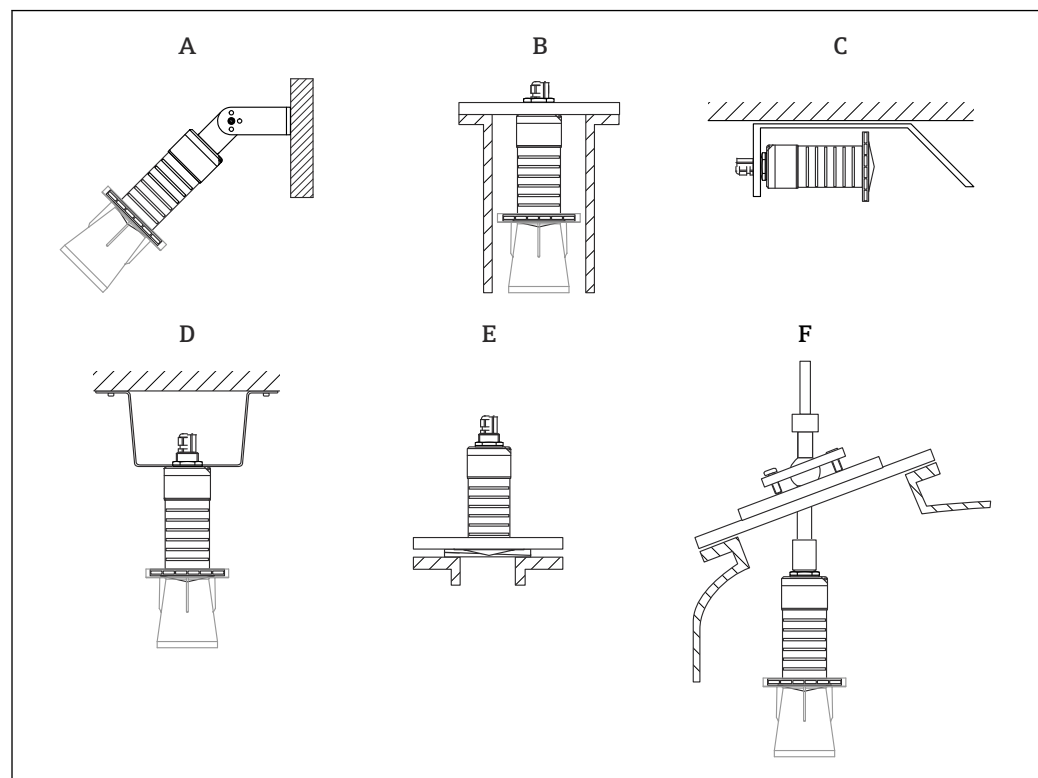
**Installation conditions****Installation types**

A0045309

**10** Wall, ceiling or nozzle installation

- A Wall or ceiling mounting, adjustable
- B Mounted at rear thread
- C Horizontal installation in cramped spaces
- D Ceiling installation with counter nut (included in delivery)
- E Installation with adjustable flange seal
- F Installation with FAU40 alignment unit

**i** **Caution!**

- The sensor cables are not designed as supporting cables. Do not use them for suspension purposes.
- Always operate the device in a vertical position in free-space applications.

**Position for installation on a vessel**

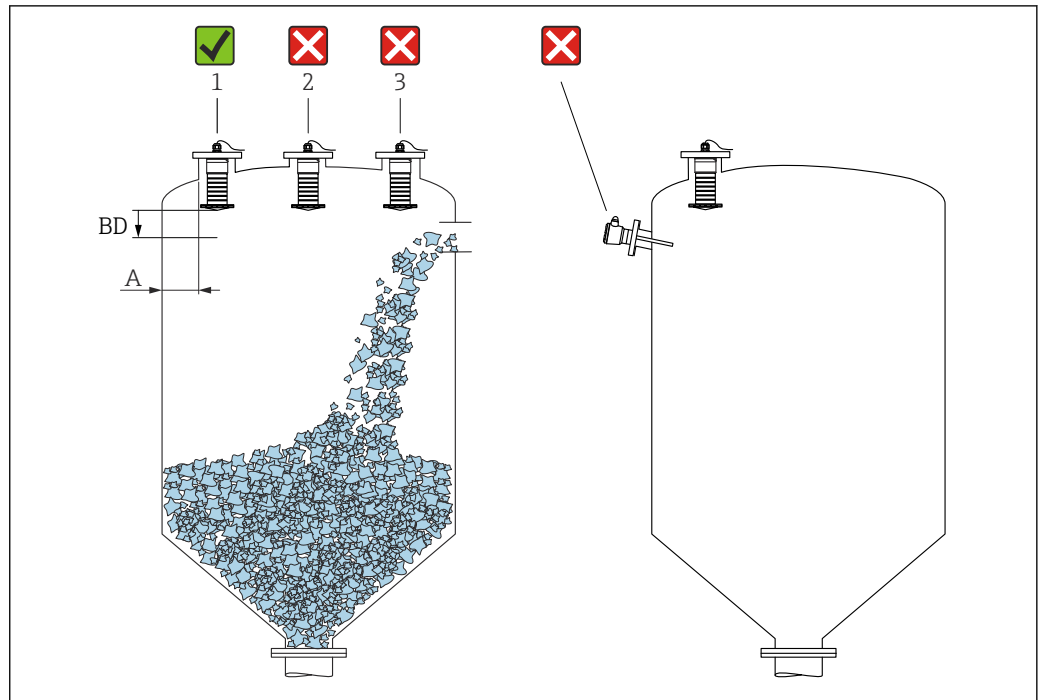

11 Installation position on a vessel

- If possible install the sensor so that its lower edge is inside the vessel.
- Recommended distance **A** wall - nozzle outer edge:  $\sim \frac{1}{6}$  of the vessel diameter. Under no circumstances should the device be mounted closer than 15 cm (5.91 in) to the vessel wall.
- Do not install the sensor in the middle of the vessel.
- Avoid measurements through the filling curtain.
- Avoid internal fixtures such as limit switches.
- No signals are evaluated within the Blocking distance (BD). It can therefore be used to suppress interference signals (e.g. the effects of condensate) in the vicinity of the antenna. An automatic Blocking distance of at least 0.1 m (0.33 ft) is configured as standard. However, this can be overwritten manually (0 m (0 ft) is also permitted).  
Automatic calculation:  
Blocking distance = Empty calibration - Full calibration - 0.2 m (0.656 ft).  
Each time a new entry is made in the **Empty calibration** parameter or **Full calibration** parameter, the **Blocking distance** parameter is recalculated automatically using this formula.  
If the result of the calculation is a value  $< 0.1$  m (0.33 ft), the Blocking distance of 0.1 m (0.33 ft) will continue to be used.

**Nozzle installation**

The antenna should project out of the nozzle for optimum measurement. The interior of the nozzle must be smooth and may not contain any edges or welded joints. The edge of the nozzle should be rounded if possible.

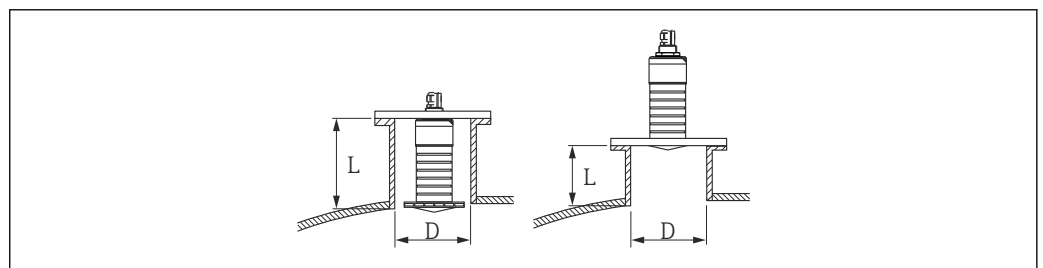

12 Nozzle installation

The maximum nozzle length **L** depends on the nozzle diameter **D**.

Please note the limits for the diameter and length of the nozzle.

**80 mm (3 in) antenna, installation inside nozzle**

- D: min. 120 mm (4.72 in)
- L: max. 205 mm (8.07 in) +  $D \times 4.5$

**80 mm (3 in) antenna, installation outside nozzle**

- D: min. 80 mm (3 in)
- L: max.  $D \times 4.5$

**Device alignment for installation on a vessel**

- Align the antenna so that it is perpendicular to the product surface
- Align the eyelet with lug towards the vessel wall as well as possible

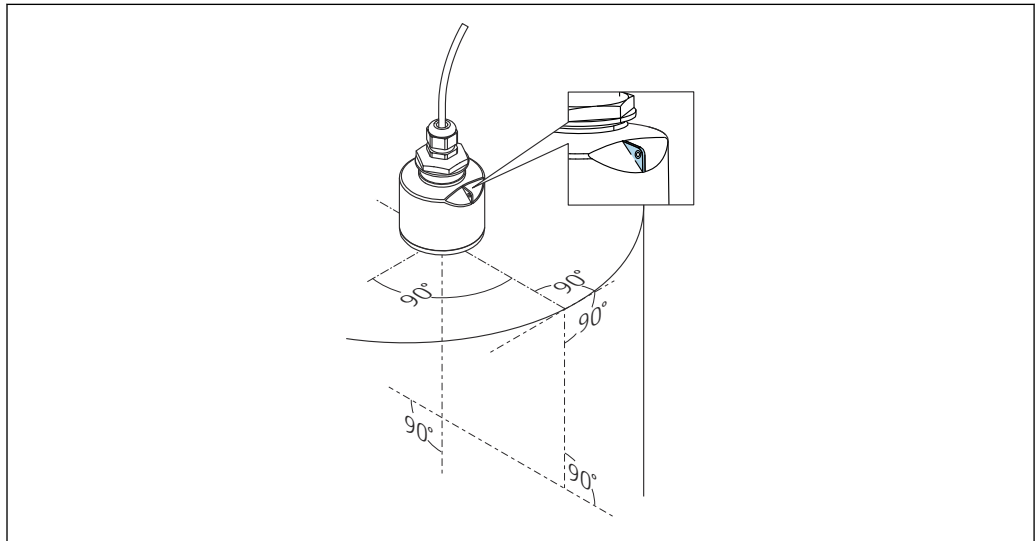

**13** Device alignment for installation on a vessel



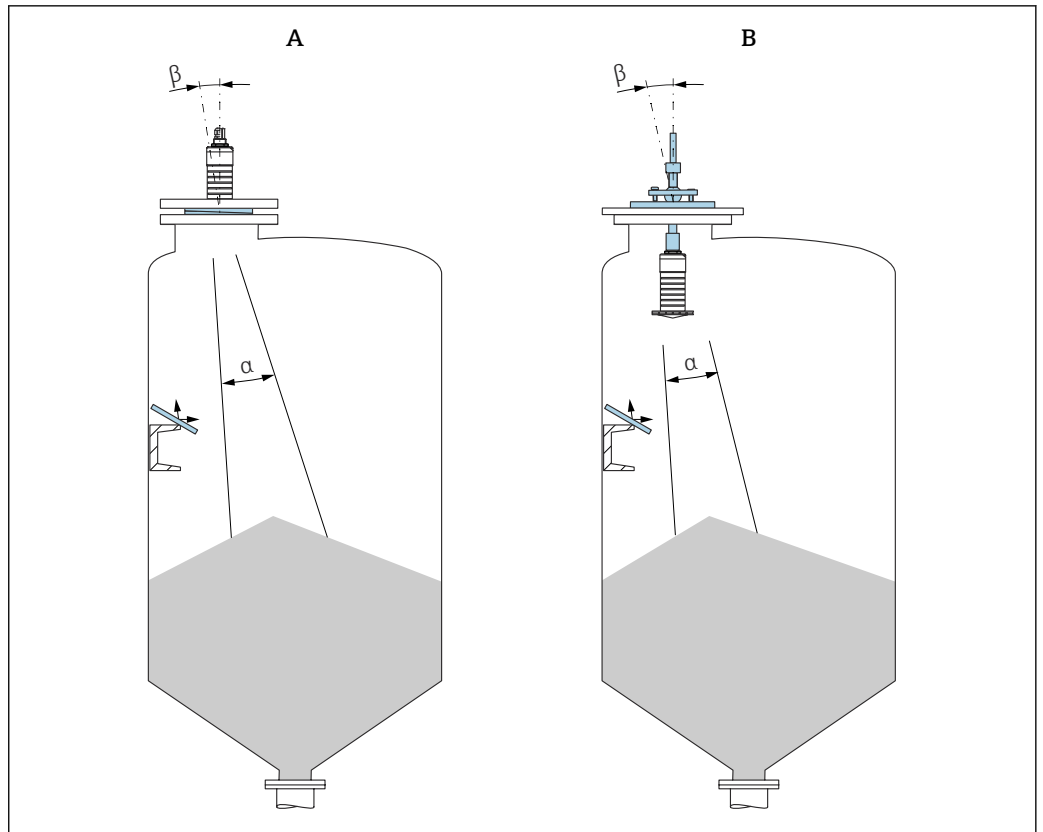

A0045325

14 Aligning the sensor with the product cone

A Installation with adjustable flange seal

B Installation with FAU40 alignment unit



To avoid disturbance echoes, use metal plates installed at an angle (where necessary)

### Beam angle

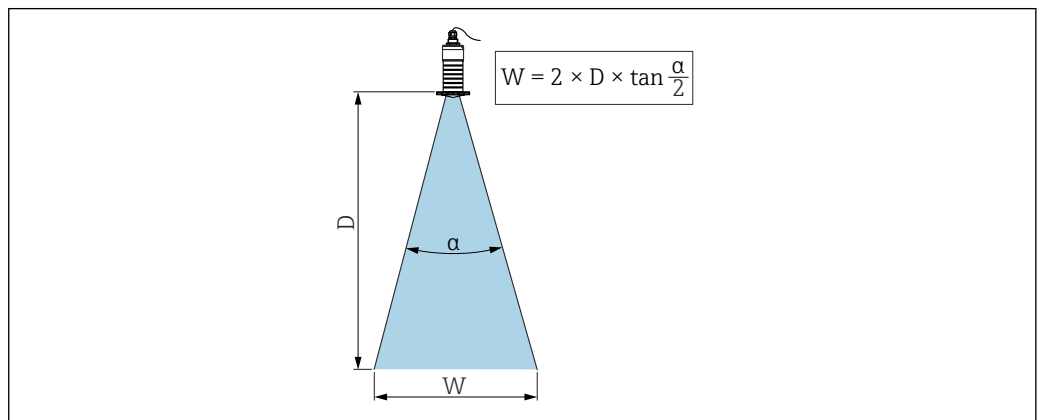

A0046285

15 Relationship between beam angle  $\alpha$ , distance  $D$  and beamwidth diameter  $W$

The beam angle is defined as the angle  $\alpha$  at which the power energy of the radar waves reaches half the value of the maximum power density (3dB width). Microwaves are also emitted outside the signal beam and can be reflected off interfering installations.

Beam diameter  $W$  as a function of beam angle  $\alpha$  and distance  $D$ .

**80 mm (3 in) antenna with or without a flooding protection tube,  $\alpha$  12°**

$$W = D \times 0.21$$

### Measurement in plastic vessels

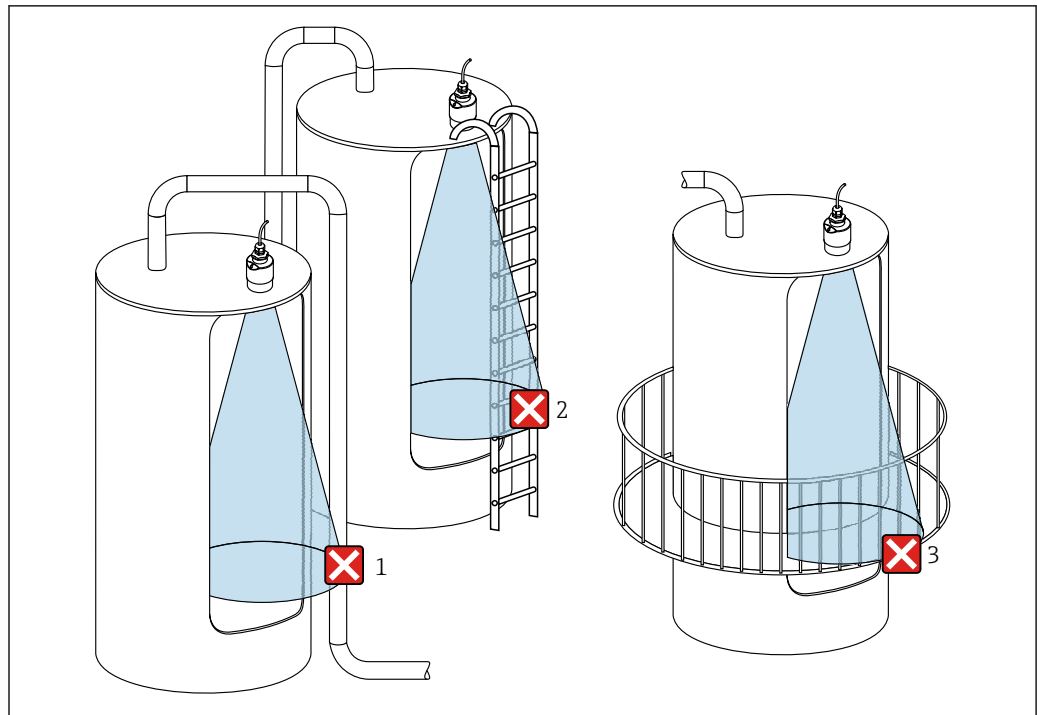

16 Measurement in a plastic vessel with a metallic, interfering installation outside of the vessel

- 1 Pipe, tubing
- 2 Ladder
- 3 Grate, railing

**i** If the outer wall of the vessel is made of a non-conductive material (e.g. GFR), microwaves can also be reflected by interfering installations outside of the vessel.

#### Optimization options

- **Adjustable flange seal:** The device can be aligned with the product surface using the adjustable flange seal.
- **Alignment unit:**  
In the case of devices with an alignment unit, the sensor can be optimally aligned with the conditions at the vessel. The maximum angle  $\beta$  is  $\pm 15^\circ$ .  
The purpose of sensor alignment is primarily to:
  - Prevent interference reflections
  - Increase the maximum possible measuring range in conical outlets
- Please ensure there are no interfering installations made of a conductive material in the signal beam (see the beam angle section for information on calculating the beamwidth diameter).

For more information: contact the Endress+Hauser sales organization.

#### Weather protection cover

A weather protection cover is recommended for outdoor use.

The weather protection cover can be ordered as an accessory or together with the device via the product structure "Accessory enclosed".

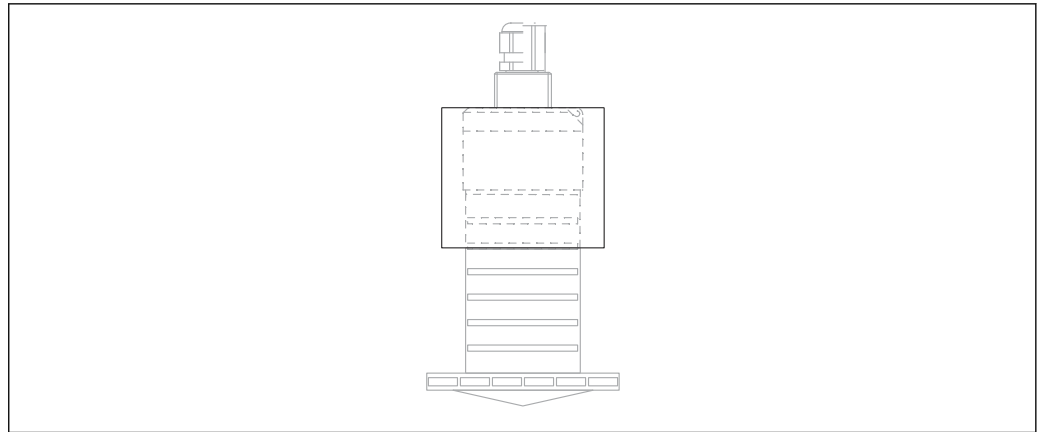

A0046286

17 Weather protection cover

**i** The sensor is not completely covered by the weather protection cover.

### Free-field measurement with flooding protection tube

In free-field installations and/or in applications where there is a risk of flooding, the flooding protection tube must be used.

The flooding protection tube can be ordered as an accessory or together with the device via the product structure "Accessory enclosed".

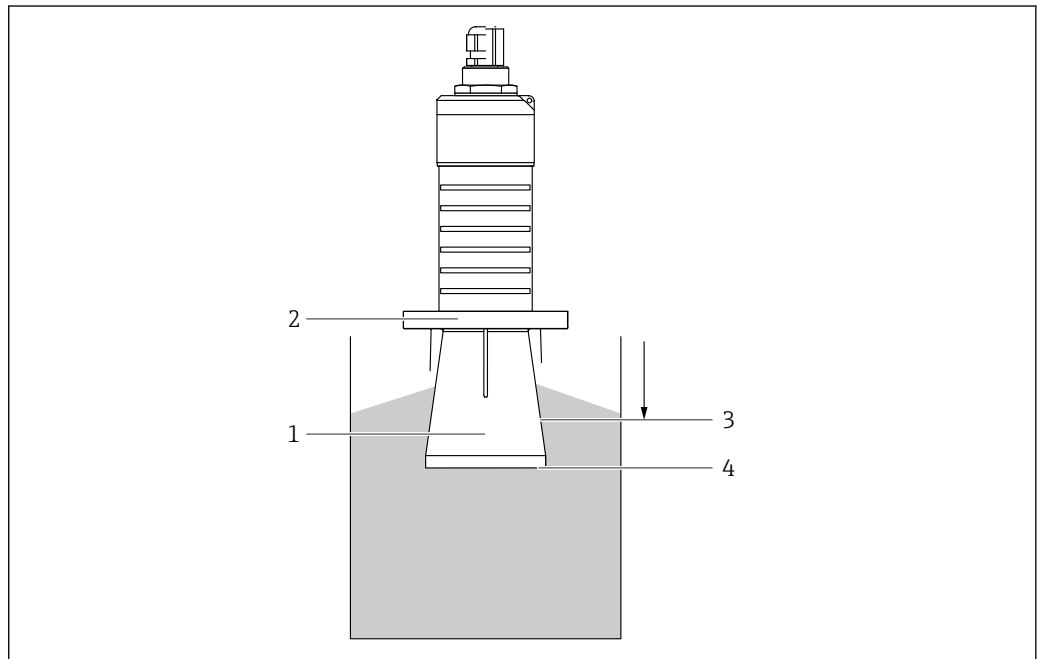

A0045326

18 Function of flooding protection tube

- 1 Empty space
- 2 O-ring (EPDM) seal
- 3 Blocking distance
- 4 Max. level

The tube is screwed directly onto the sensor and seals off the system by means of an O-ring making it air-tight. In the event of flooding, the empty space that develops in the tube ensures a defined detection of the maximum level directly at the end of the tube. Due to the fact that the Blocking distance is inside the tube, multiple echoes are not analyzed.

### Installation with mounting bracket, adjustable

The mounting bracket can be ordered as an accessory or together with the device via the product structure "Accessory enclosed".

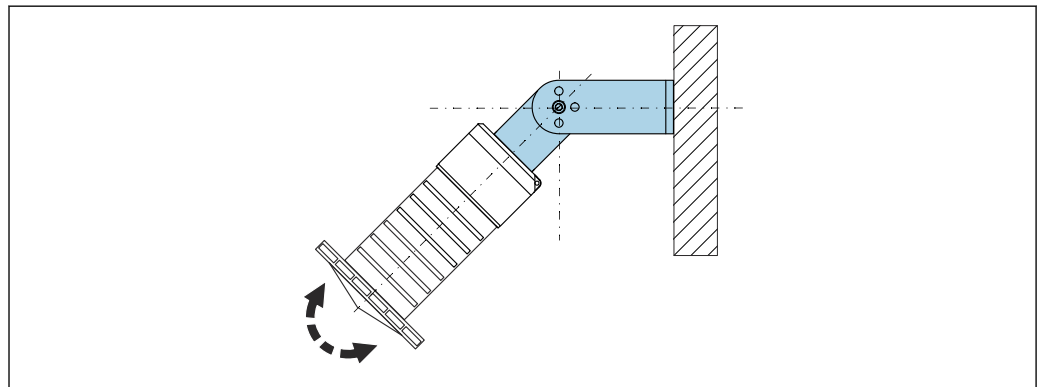

A0046287

■ 19 Installation with mounting bracket, adjustable

- Wall or ceiling installation is possible.
- Using the mounting bracket, position the antenna so that it is perpendicular to the product surface.

#### NOTICE

**There is no conductive connection between the mounting bracket and transmitter housing.** Electrostatic charging possible.

- ▶ Integrate the mounting bracket in the local potential equalization system.

### Cantilever installation, with pivot

The cantilever, wall bracket and mounting frame are available as accessories.

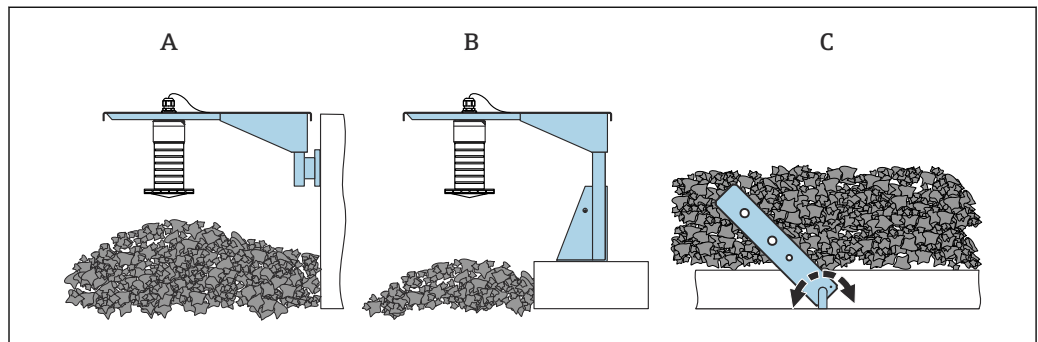

A0045327

■ 20 Cantilever installation, with pivot

- A Cantilever with wall bracket
- B Cantilever with mounting frame
- C Cantilever, pivotable

### Installation with the horizontal mounting bracket

The mounting bracket can be ordered together with the device via the product structure "Accessory enclosed".

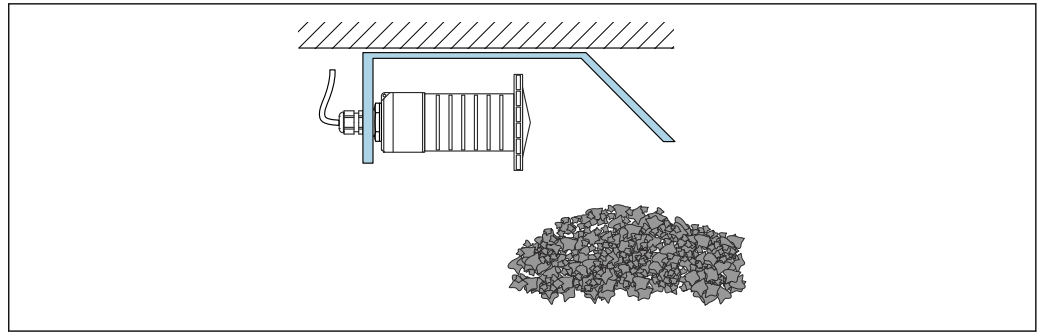

A0045328

21 Installation with the horizontal mounting bracket (without flooding protection tube)

### Installation with pivotable mounting bracket

The pivotable mounting bracket can be ordered together with the device via the product structure "Accessory enclosed".

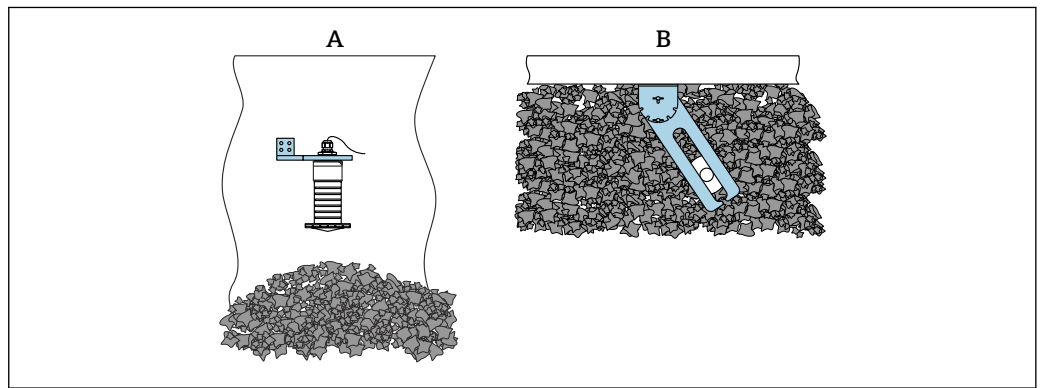

A0045329

22 Installation, pivotable and adjustable

A Cantilever with wall bracket

B Cantilever pivotable and adjustable (to align the device with the medium to be measured)

### FAU40 alignment unit

An angle of inclination of up to 15° in all directions can be set for the antenna axis using the FAU40 alignment unit. The alignment unit is used to optimally direct the radar beam at the bulk solids.

The FAU40 alignment unit is available as an accessory.

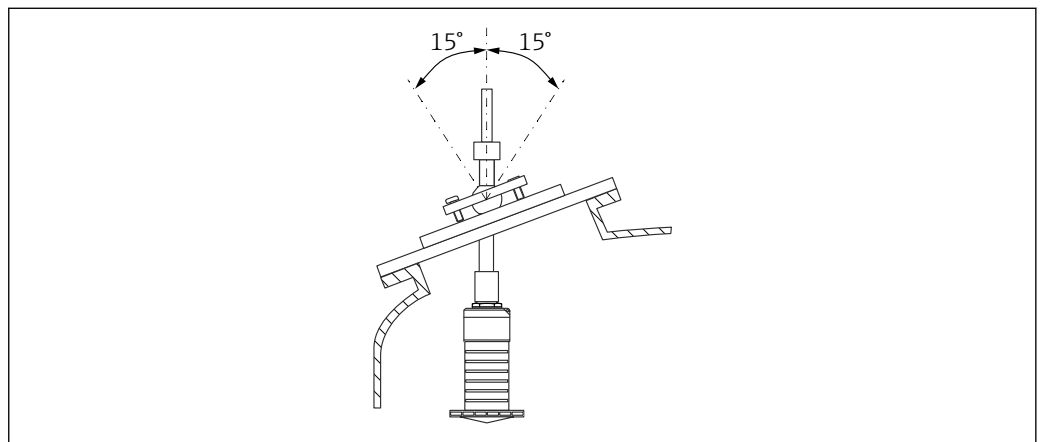

A0045332

23 Micropilot FMR20 with alignment unit

**Adjustable flange seal**

The radar beam can be optimally directed at the bulk solids using the adjustable flange seal.

The adjustable flange seal can be ordered together with the device via the product structure "Accessory enclosed".

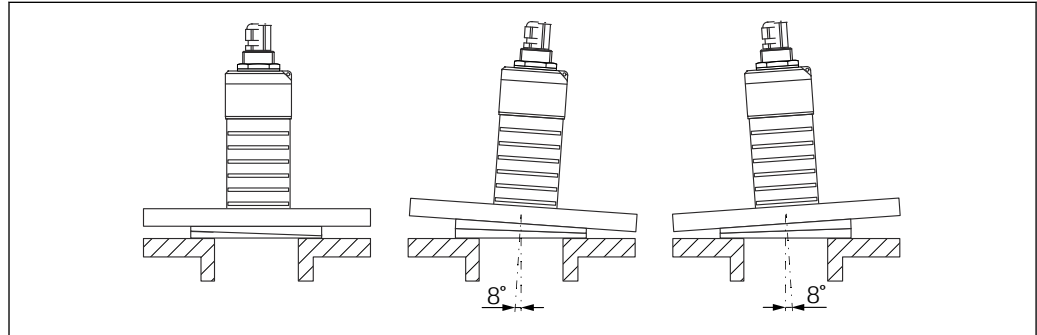

A0045331

24 Micropilot FMR20 with adjustable flange seal

**Environment**

<b>Ambient temperature range</b>	Measuring device: -40 to +80 °C (-40 to +176 °F) <b>i</b> It may not be possible to use the Bluetooth connection at ambient temperatures > 60 °C (140 °F). Outdoor operation in strong sunlight: <ul style="list-style-type: none"> <li>■ Mount the device in the shade.</li> <li>■ Avoid direct sunlight, particularly in warm climatic regions.</li> <li>■ Use a weather protection cover.</li> </ul>
<b>Storage temperature</b>	-40 to +80 °C (-40 to +176 °F)
<b>Climate class</b>	DIN EN 60068-2-38 (test Z/AD)
<b>Operating altitude as per IEC 61010-1 Ed.3</b>	Generally up to 2 000 m (6 600 ft) above sea level.
<b>Degree of protection</b>	Tested acc. to: <ul style="list-style-type: none"> <li>■ IP66, NEMA 4X</li> <li>■ IP68, NEMA 6P (24 h at 1.83 m (6.00 ft) 1.83 m under water)</li> </ul>
<b>Vibration resistance</b>	DIN EN 60068-2-64/IEC 60068-2-64: 20 to 2 000 Hz, 1 (m/s <sup>2</sup> ) <sup>2</sup> /Hz
<b>Electromagnetic compatibility (EMC)</b>	Electromagnetic compatibility in accordance with all of the relevant requirements outlined in the EN 61000 series and NAMUR Recommendation EMC (NE 21). Details are provided in the Declaration of Conformity ( <a href="http://www.endress.com/downloads">www.endress.com/downloads</a> ).

## Process

Process temperature, process pressure

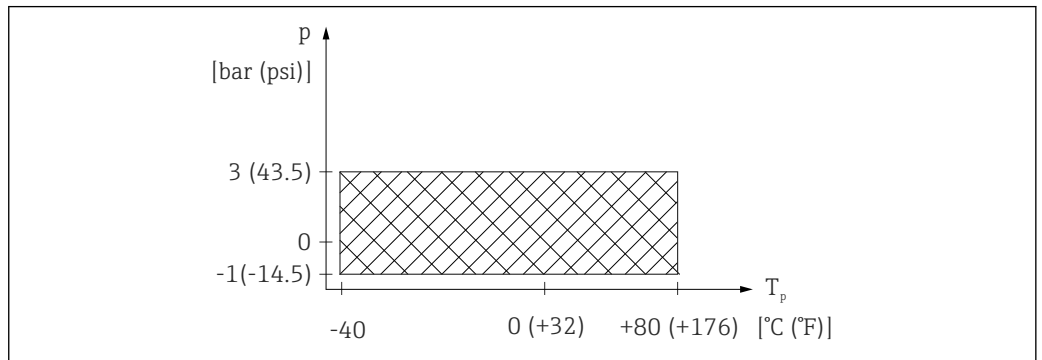

A0029007-EN

25 FMR20: Permitted range for process temperature and process pressure

### Process temperature range

-40 to +80 °C (-40 to +176 °F)

### Process pressure range, threaded process connection

- $p_{\text{gauge}} = -1$  to 3 bar (-14.5 to 43.5 psi)
- $p_{\text{abs}} < 4$  bar (58 psi)

### Process pressure range, UNI flange process connection

- $p_{\text{gauge}} = -1$  to 1 bar (-14.5 to 14.5 psi)
- $p_{\text{abs}} < 2$  bar (29 psi)



The pressure range may be further restricted in the event of a CRN approval.

Dielectric constant

### For solids

- $\epsilon_r \geq 2$
- Contact Endress+Hauser for lower  $\epsilon_r$  values



For dielectric constants (DC values) of many media commonly used in various industries refer to:

- the Endress+Hauser DC manual (CP01076F)
- the Endress+Hauser "DC Values App" (available for Android and iOS)

## Mechanical construction

### Dimensions

### 80 mm (3 in) Antenna

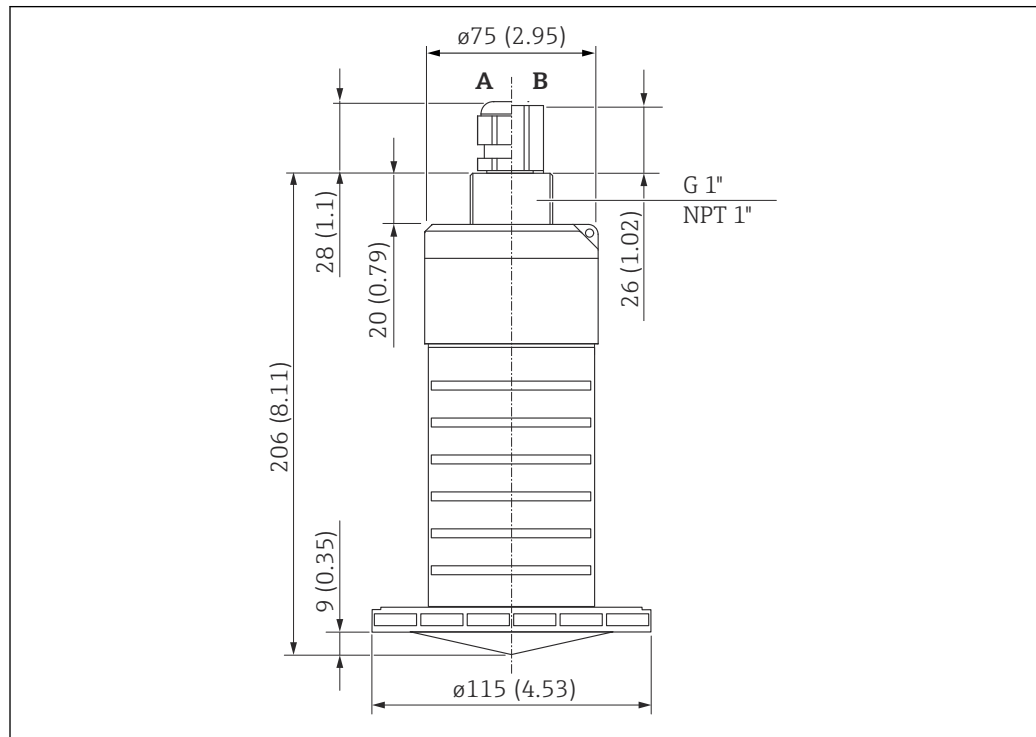

26 Dimensions of 80 mm (3 in) antenna; engineering unit: mm (in)

- A Cable gland
- B FNPT 1/2" conduit



80 mm (3 in) antenna with flooding protection tube

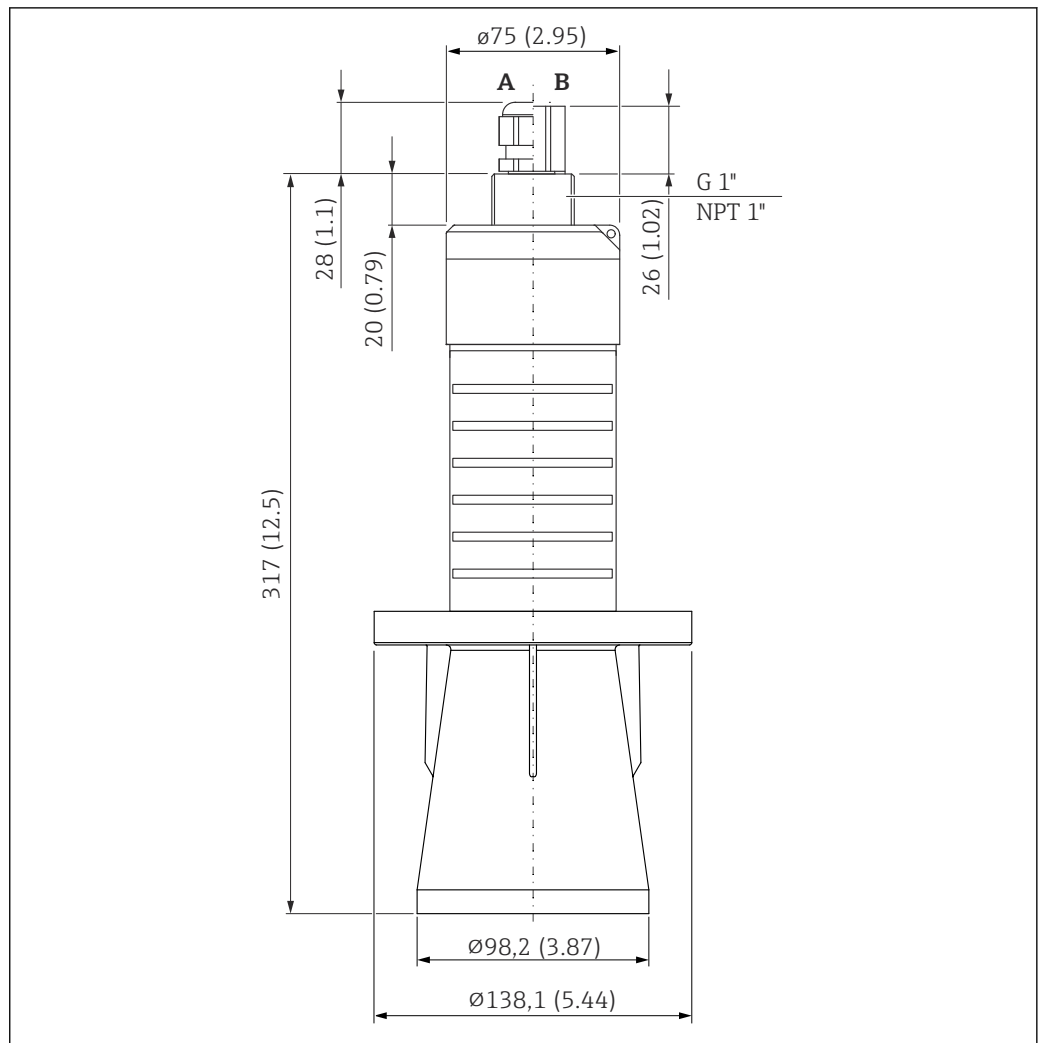

27 Dimensions of 80 mm (3 in) antenna mounted with flooding protection tube, engineering unit: mm (in)

- A Cable gland
- B FNPT ½" conduit

The flooding protection tube, metalized PBT-PC, can be ordered together with the device via the product structure "Accessory enclosed".

**80 mm (3 in) antenna with slip-on flange 3"/DN80**

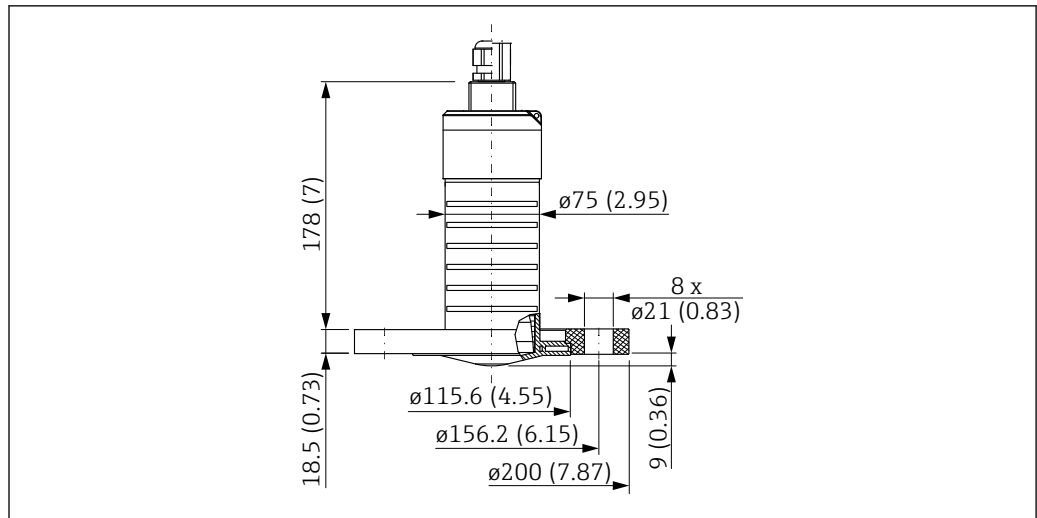

A0028813

28 Dimensions of 80 mm (3 in) antenna with slip-on flange 3"/DN80, engineering unit: mm (in)

The slip-on flange 3"/DN80, PVDF, can be ordered together with the device via the product structure "Accessory enclosed".

**80 mm (3 in) antenna with slip-on flange 4"/DN100**

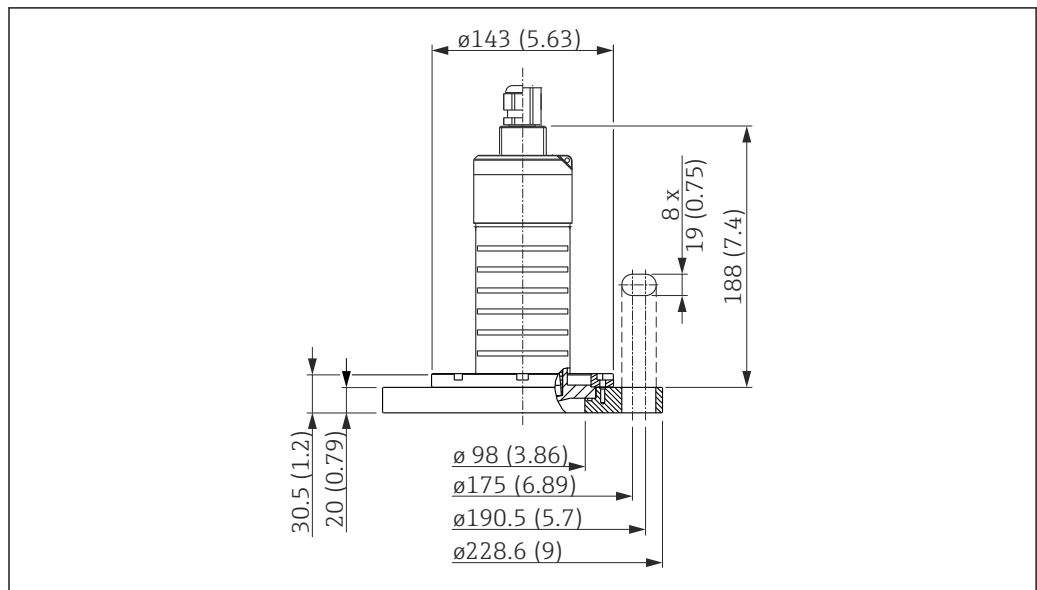

A0028816

29 Dimensions of 80 mm (3 in) antenna with slip-on flange 4"/DN100, engineering unit: mm (in)

The slip-on flange 4"/DN100, PVDF, can be ordered together with the device via the product structure "Accessory enclosed".

**80 mm (3 in) antenna with slip-on flange 6"/DN150**

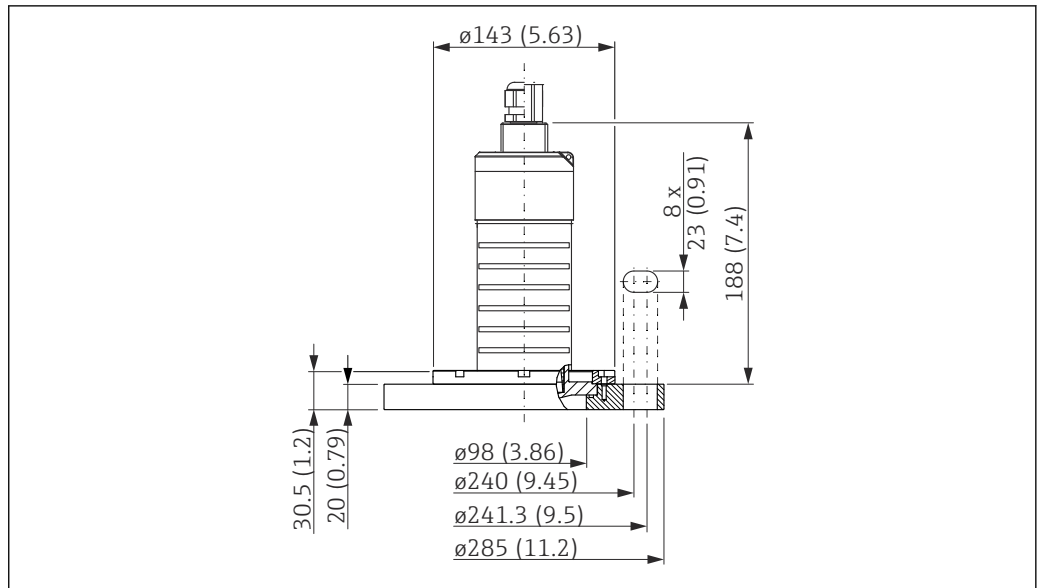

A0028818

30 Dimensions of 80 mm (3 in) antenna with slip-on flange 6"/DN150, engineering unit: mm (in)

The slip-on flange 6"/DN150, PVDF, can be ordered together with the device via the product structure "Accessory enclosed".

**Counter nut for process connection, rear side**

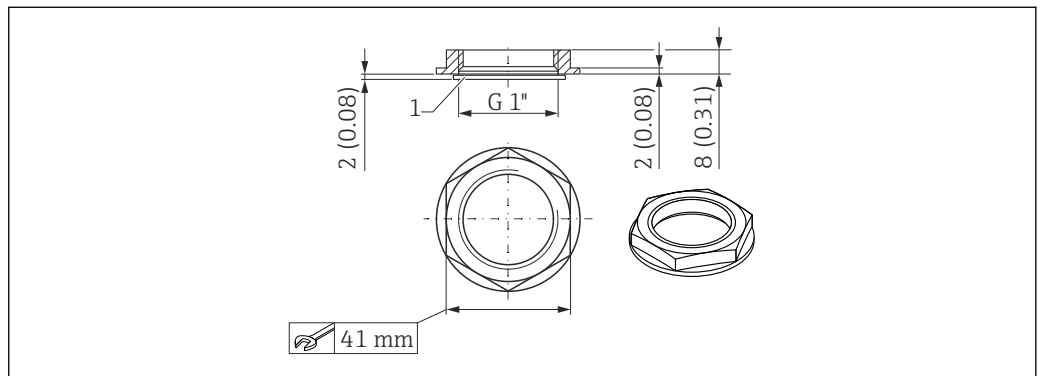

A0028419

31 Dimensions of counter nut for process connection, rear side, engineering unit: mm (in)

1 Seal

- The counter nut with seal (EPDM) is included in the scope of supply
- Material: PA66

**Weight**

**Weight (including 5 m (16.4 ft) cable)**

Device with 80 mm (3 in) antenna: approx. 2.8 kg (6.2 lb)

**Materials**

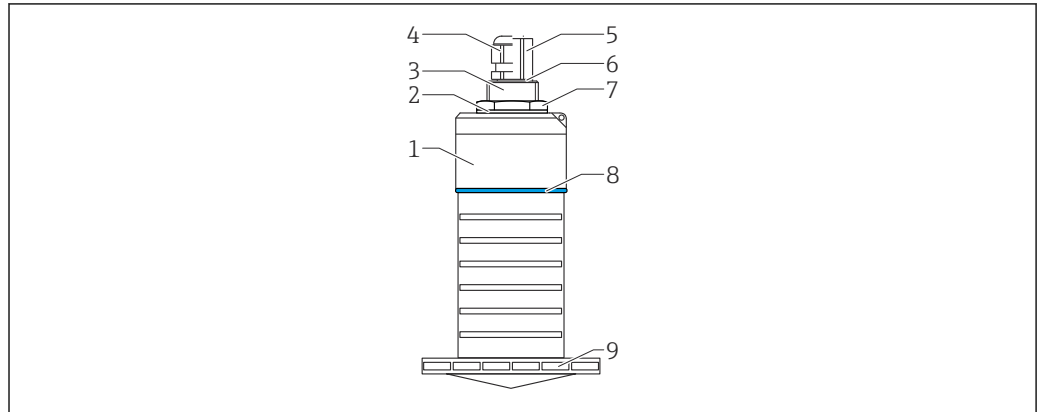

A0046292

32 Overview of materials

80 mm (3 in) antenna

- 1 Sensor housing; PVDF
- 2 Seal; EPDM
- 3 Process connection, rear side; PVDF
- 4 Cable gland; PA
- 5 Conduit adapter; CuZn nickel-plated
- 6 O-ring; EPDM
- 7 Counter nut; PA6.6
- 8 Design ring; PBT-PC
- 9 Process connection, front side; PVDF

**Connecting cable**

Available cable length: 5 to 300 m (16 to 980 ft)

Material : PVC

**Operability**

**Operating concept**

- Modbus
- SmartBlue (app) via Bluetooth® wireless technology
- Menu guidance with brief explanations of the individual parameter functions in the operating tool

**Operation via Bluetooth® wireless technology**

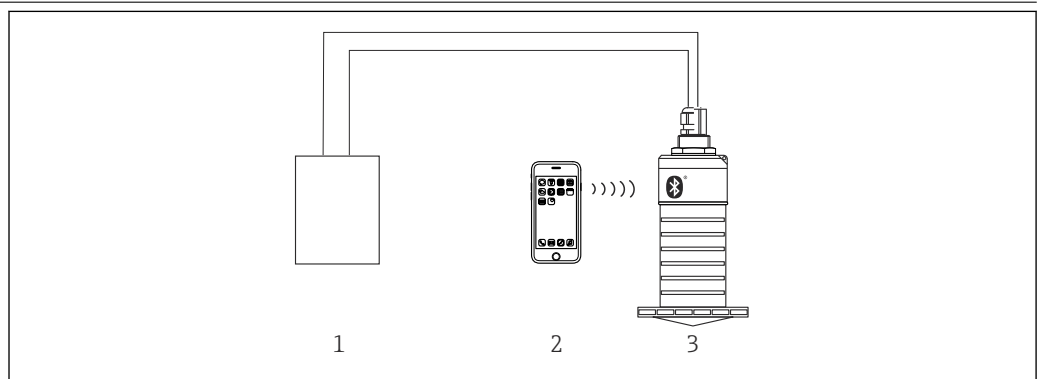

A0046293

33 Possibilities for remote operation via Bluetooth® wireless technology

- 1 Transmitter power supply unit
- 2 Smartphone / tablet with SmartBlue (app)
- 3 Transmitter with Bluetooth® wireless technology

**Remote operation via Modbus protocol**

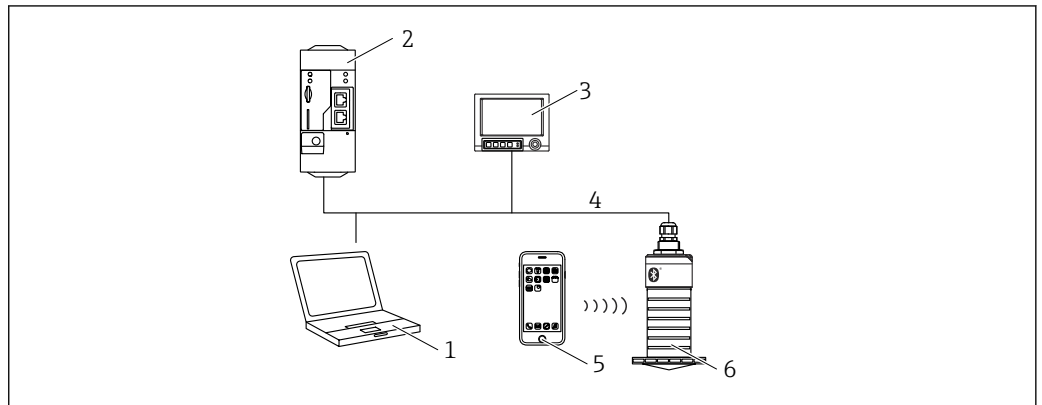

A0046459

34 Options for remote operation via Modbus protocol

- 1 Computer with Modbus operating tool (customer application, terminal application, etc.)
- 2 Remote Transmit Unit (RTU) with Modbus (e.g. Fieldgate FXA42)
- 3 Memograph M RSG45
- 4 Modbus RS485
- 5 Smartphone / tablet with SmartBlue (app)
- 6 Transmitter with Modbus and Bluetooth® wireless technology

## Certificates and approvals



The availability of approvals and certificates can be called up daily via the Product Configurator.

<b>CE mark</b>	The measuring system meets the legal requirements of the applicable EU Directives. These are listed in the corresponding EU Declaration of Conformity along with the standards applied. Endress+Hauser confirms successful testing of the device by affixing to it the CE mark.
<b>RoHS</b>	The measuring system complies with the substance restrictions of the Restriction on Hazardous Substances Directive 2011/65/EU (RoHS 2).
<b>EAC conformity</b>	The measuring system meets the legal requirements of the applicable EAC guidelines. These are listed in the corresponding EAC Declaration of Conformity together with the standards applied. Endress+Hauser confirms successful testing of the device by affixing to it the EAC mark.
<b>RCM marking</b>	The supplied product or measuring system meets the ACMA (Australian Communications and Media Authority) requirements for network integrity, interoperability, performance characteristics as well as health and safety regulations. Here, especially the regulatory arrangements for electromagnetic compatibility are met. The products bear the RCM marking on the nameplate.



A0029561

### Approvals

- Non-hazardous area
- ATEX II 1 G Ex ia IIC T4 Ga
- ATEX II 1/2 G Ex ia IIC T4 Ga/Gb
- CSA C/US General Purpose
- CSA C/US IS Cl.I Div.1 Gr.A-D, AEx ia / Ex ia T4
- IEC Ex ia IIC T4 Ga/Gb

Additional safety instructions must be followed for use in hazardous areas. Please refer to the separate "Safety Instructions" (XA) document included in the delivery. Reference to the applicable XA can be found on the nameplate.

### Explosion-protected smartphones and tablets

Only mobile end devices with Ex approval may be used in hazardous areas.

### Pressure equipment with allowable pressure ≤ 200 bar (2 900 psi)

Pressure instruments with a flange and threaded boss that do not have a pressurized housing do not fall within the scope of the Pressure Equipment Directive, irrespective of the maximum allowable pressure.

#### Reasons:

According to Article 2, point 5 of EU Directive 2014/68/EU, pressure accessories are defined as "devices with an operational function and having pressure-bearing housings".

If a pressure instrument does not have a pressure-bearing housing (no identifiable pressure chamber of its own), there is no pressure accessory present within the meaning of the Directive.

### EN 302729-1/2 radio standard

The devices comply with the LPR (Level Probing Radar) radio standard EN 302729-1/2 and are approved for unrestricted use inside and outside of closed vessels in countries of the EU and EFTA. As a prerequisite, the countries in question must have already implemented this standard.

The following countries are those that have currently implemented the standard:

Belgium, Bulgaria, Germany, Denmark, Estonia, France, Greece, UK, Ireland, Iceland, Italy, Liechtenstein, Lithuania, Latvia, Malta, The Netherlands, Norway, Austria, Poland, Portugal, Romania, Sweden, Switzerland, Slovakia, Spain, Czech Republic and Cyprus.

Implementation is still underway in all of the countries not listed.

Please note the following for operation of the devices outside of closed vessels:

1. The device must be mounted in accordance with the instructions in the "Installation" section.
2. Installation must be carried out by properly trained, expert staff.
3. The device antenna must be installed in a fixed location pointing vertically downwards.
4. The installation site must be located at a distance of 4 km from the astronomy stations listed below or otherwise approval must be provided by the relevant authority. If the device is installed at a distance of 4 to 40 km from one of the listed stations, it must not be installed at a height of more than 15 m (49 ft) above the ground.

*Astronomy stations*

Country	Name of the station	Latitude	Longitude
Germany	Effelsberg	50°31'32" North	06°53'00" East
Finland	Metsähovi	60°13'04" North	24°23'37" East
	Tuorla	60°24'56" North	24°26'31" East
France	Plateau de Bure	44°38'01" North	05°54'26" East
	Floirac	44°50'10" North	00°31'37" West
Great Britain	Cambridge	52°09'59" North	00°02'20" East
	Damhall	53°09'22" North	02°32'03" West
	Jodrell Bank	53°14'10" North	02°18'26" West
	Knockin	52°47'24" North	02°59'45" West
	Pickmere	53°17'18" North	02°26'38" West
Italy	Medicina	44°31'14" North	11°38'49" East
	Noto	36°52'34" North	14°59'21" East
	Sardinia	39°29'50" North	09°14'40" East
Poland	Fort Skala Krakow	50°03'18" North	19°49'36" East
Russia	Dmitrov	56°26'00" North	37°27'00" East
	Kalyazin	57°13'22" North	37°54'01" East
	Pushchino	54°49'00" North	37°40'00" East
	Zelenchukskaya	43°49'53" North	41°35'32" East
Sweden	Onsala	57°23'45" North	11°55'35" East
Switzerland	Bleien	47°20'26" North	08°06'44" East
Spain	Yebes	40°31'27" North	03°05'22" West
	Robledo	40°25'38" North	04°14'57" West
Hungary	Penc	47°47'22" North	19°16'53" East



As a general rule, the requirements outlined in EN 302729-1/2 must be observed.

**FCC / Industry Canada**

This device complies with Part 15 of the FCC Rules [and with Industry Canada license-exempt RSS standard(s)]. Operation is subject to the following two conditions: (1) this device may not cause harmful interference, and (2) this device must accept any interference received, including interference that may cause undesired operation.

*Le présent appareil est conforme aux CNR d'Industrie Canada applicables aux appareils radio exempts de licence. L'exploitation est autorisée aux deux conditions suivantes: (1) l'appareil ne doit pas produire de brouillage, et (2) l'utilisateur de l'appareil doit accepter tout brouillage radioélectrique subi, même si le brouillage est susceptible d'en compromettre le fonctionnement.*

[Any] Changes or modifications made to this equipment not expressly approved by Endress+Hauser may void the FCC authorization to operate this equipment.

- i** This equipment has been tested and found to comply with the limits for a Class B digital device, pursuant to Part 15 of the FCC Rules. These limits are designed to provide reasonable protection against harmful interference in a residential installation. This equipment generates, uses and can radiate radio frequency energy and, if not installed and used in accordance with the instructions, may cause harmful interference to radio communications. However, there is no guarantee that interference will not occur in a particular installation. If this equipment does cause harmful interference to radio or television reception, which can be determined by turning the equipment off and on, the user is encouraged to try to correct the interference by one or more of the following measures:
- Reorient or relocate the receiving antenna
  - Increase the separation between the equipment and receiver
  - Connect the equipment into an outlet on a circuit different from that to which the receiver is connected
  - Consult the dealer or an experienced radio/TV technician for help
- i**
- The installation of the LPR/TLPR device shall be done by trained installers, in strict compliance with the manufacturer's instructions.
  - The use of this device is on a "no-interference, no-protection" basis. That is, the user shall accept operations of high-powered radar in the same frequency band which may interfere with or damage this device. However, devices found to interfere with primary licensing operations will be required to be removed at the user's expense.
  - Only for usage without the accessory "flooding protection tube", i.e. NOT in the free-field: This device shall be installed and operated in a completely enclosed container to prevent RF emissions, which can otherwise interfere with aeronautical navigation.

#### FCC / Industry Canada IDs

##### Tank level-probing radar

- **HVIN: FMR20**
  - FCC ID: LCGFMR2XK
  - Industry Canada ID: 2519A-2K
- **HVIN: FMR20X**
  - FCC ID: LCGFMR2XKT
  - Industry Canada ID: 2519A-2KT

##### Level-probing radar:

- **HVIN: FMR20+R7; FMR20+R8**
  - FCC ID: LCGFMR2XKF
  - Industry Canada ID: 2519A-2KF
- **HVIN: FMR20+R7X; FMR20+R8X**
  - FCC ID: LCGFMR2XKL
  - Industry Canada ID: 2519A-2KL

#### Mexico

El funcionamiento de este equipo está sujeto a las dos condiciones siguientes:

- (1) Este equipo o aparato no puede causar interferencias perjudiciales.
- (2) Este equipo o aparato debe aceptar todas las interferencias, incluyendo las que puedan causar un funcionamiento indeseado del equipo o aparato.

Este producto contiene un módulo inalámbrico

Marca: Endress+Hauser

Modelo: FMR20

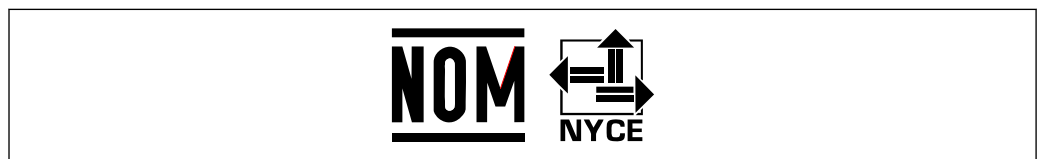

A0034100



## Other standards and guidelines

- IEC/EN 61010-1  
Protection Measures for Electrical Equipment for Measurement, Control, Regulation and Laboratory Procedures
- IEC/EN 55011  
"EMC Emission, RF Emission for Class B". Industrial, scientific and medical equipment – Electromagnetic disturbance characteristics - Limits and methods of measurement
- IEC/EN 61000-4-2  
EMC Immunity, ESD (Performance Criteria A). Electromagnetic compatibility (EMC): Testing and measurement techniques - Electrostatic discharge immunity test (ESD)
- IEC/EN 61000-4-3  
EMC Immunity, RF field susceptibility (Performance Criteria A). Electromagnetic compatibility (EMC): Testing and measurement techniques - Radiated, radio-frequency, electromagnetic field immunity test
- IEC/EN 61000-4-4  
EMC Immunity, bursts (Performance Criteria B). Electromagnetic compatibility (EMC): Testing and measurement techniques - Electrical fast transient/burst immunity test
- IEC/EN 61000-4-5  
EMC Immunity, surge (Performance Criteria B). Electromagnetic compatibility (EMC): Testing and measurement techniques - Surge immunity test
- IEC/EN 61000-4-6  
EMC Immunity, conducted RF (Performance Criteria A). Electromagnetic compatibility (EMC): Testing and measurement techniques - Immunity to conducted disturbances induced by radio-frequency fields
- IEC/EN 61000-4-8  
EMC Immunity, magnetic fields 50 Hz. Electromagnetic compatibility (EMC): Testing and measurement techniques - Power frequency magnetic field immunity test
- EN 61000-6-3  
EMC Emission, conducted RF. EMC: Radiated interference - Residential, commercial and light industry environment
- NAMUR NE 21  
Electromagnetic compatibility (EMC) of industrial process and laboratory control equipment
- NAMUR NE 43  
Standardization of the signal level for the breakdown information of digital transmitters with analog output signal.
- NAMUR NE 107  
Status classification as per NE107
- NAMUR NE 131  
Requirements for field devices for standard applications
- IEEE 802.15.1  
Requirements for the *Bluetooth*® wireless technology interface

## Ordering information

Detailed ordering information is available from your nearest sales organization [www.addresses.endress.com](http://www.addresses.endress.com) or in the Product Configurator under [www.endress.com](http://www.endress.com) :

1. Click Corporate
2. Select the country
3. Click Products
4. Select the product using the filters and search field
5. Open the product page

The Configuration button opens the Product Configurator.



### Product Configurator - the tool for individual product configuration

- Up-to-the-minute configuration data
- Depending on the device: Direct input of measuring point-specific information such as measuring range or operating language
- Automatic verification of exclusion criteria
- Automatic creation of the order code and its breakdown in PDF or Excel output format
- Ability to order directly in the Endress+Hauser Online Shop

## Accessories

### Device-specific accessories

#### Weather protection cover

The weather protection cover can be ordered together with the device via the product structure "Accessory enclosed".

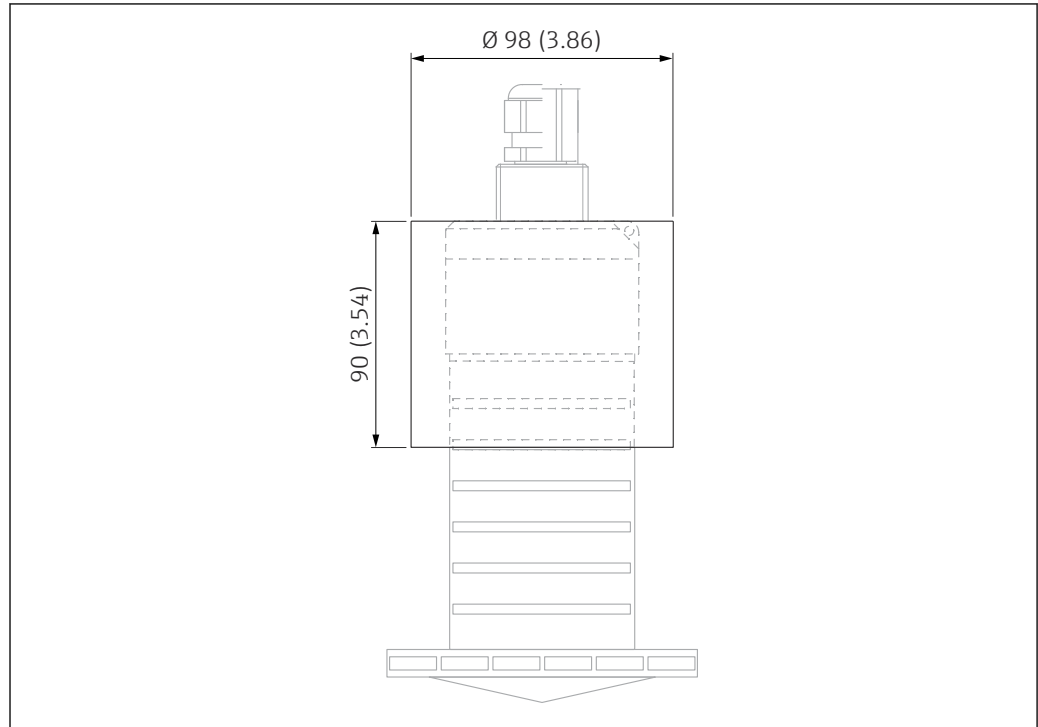

 35 Dimensions of weather protection cover, engineering unit: mm (in)

**Material**  
PVDF

**Order number**  
52025686

 The sensor is not completely covered by the weather protection cover.

**Flooding protection tube 80 mm (3 in)**

Suitable for use with devices with a 80 mm (3 in) antenna and "Mounting customer side w/o flange" process connection.

The flooding protection tube can be ordered together with the device via the product structure "Accessory enclosed".

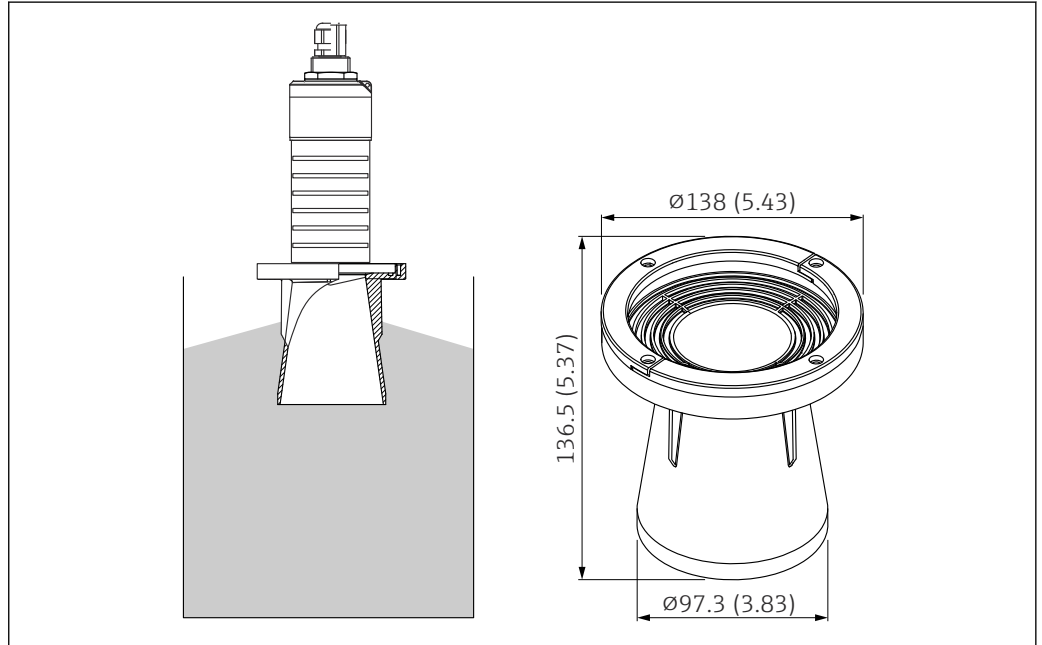

36 Dimensions of flooding protection tube 80 mm (3 in), engineering unit: mm (in)

A0045346

**Material**

PBT-PC, metalized

**Order number**

71327051

**Mounting bracket, adjustable**

The mounting bracket can be ordered together with the device via the product structure "Accessory enclosed".

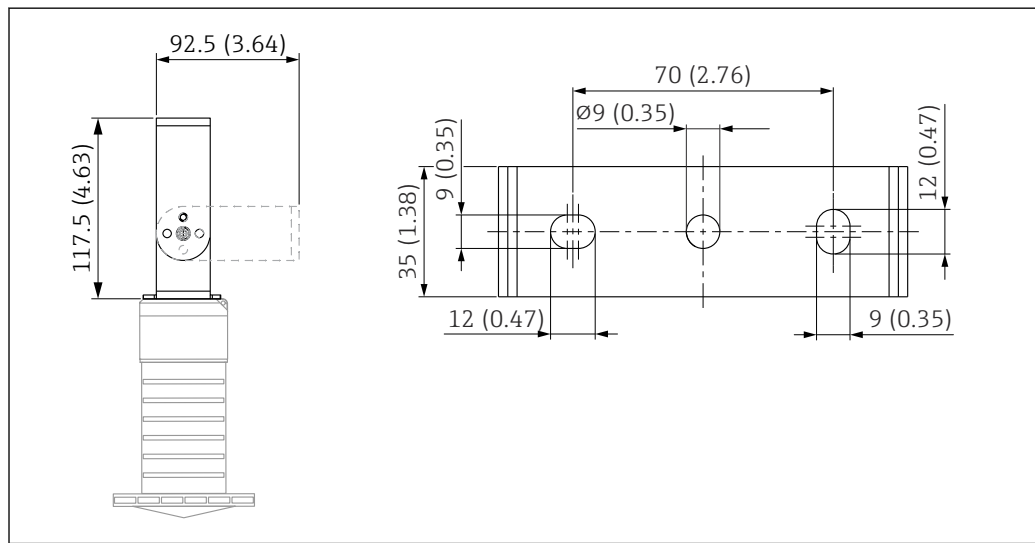

A0046296

37 Dimensions of mounting bracket, engineering unit: mm (in)

Consists of:

- 1 × mounting bracket, 316L (1.4404)
- 1 × angle bracket, 316L (1.4404)
- 3 × screws, A4
- 3 × securing disks, A4

**Order number**

71325079

**UNI flange 3"/DN80/80, PP**

The UNI flange 3"/DN80/80 can be ordered together with the device via the product structure "Accessory enclosed".

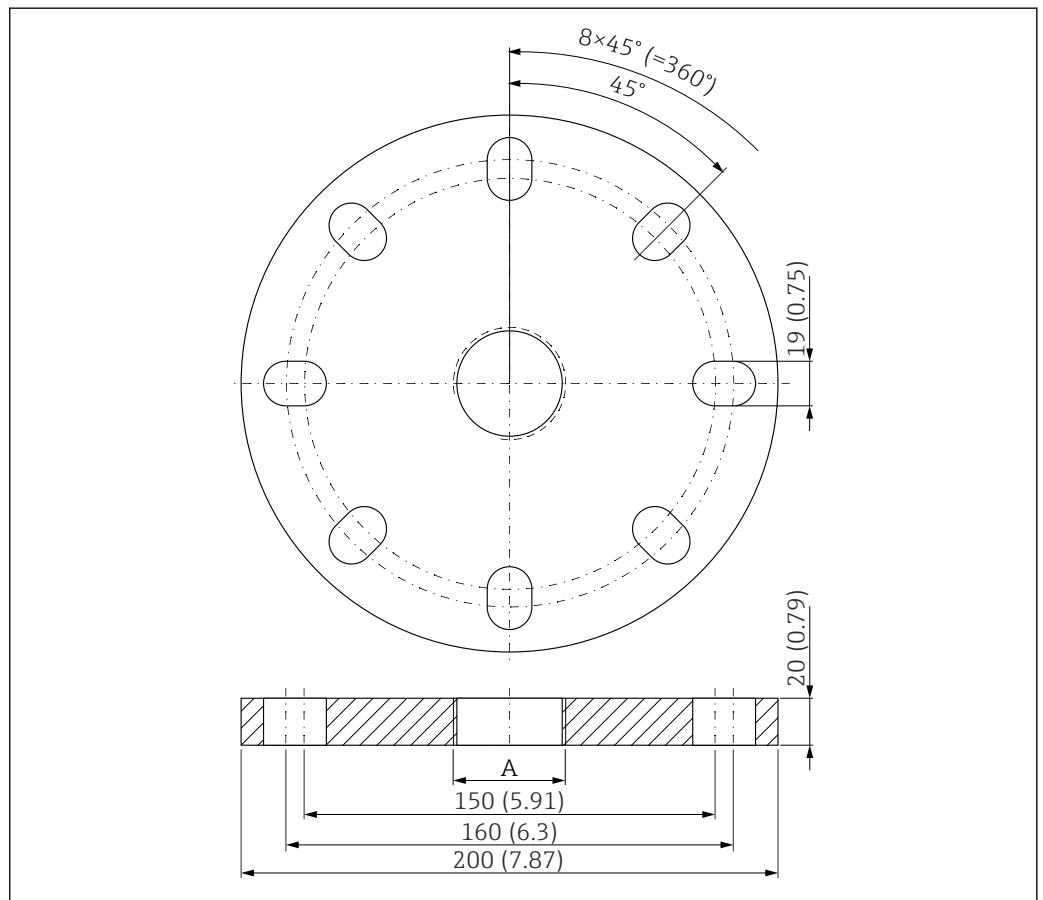

A0037947

38 Dimensions of UNI flange 3"/DN80/80, engineering unit: mm (in)

A Sensor connection in accordance with product structure "Process connection on rear"

**Material**

PP

**Order number**

FAX50-####

**UNI flange 4"/DN100/100, PP**

The UNI flange 4"/DN100/100 can be ordered together with the device via the product structure "Accessory enclosed".

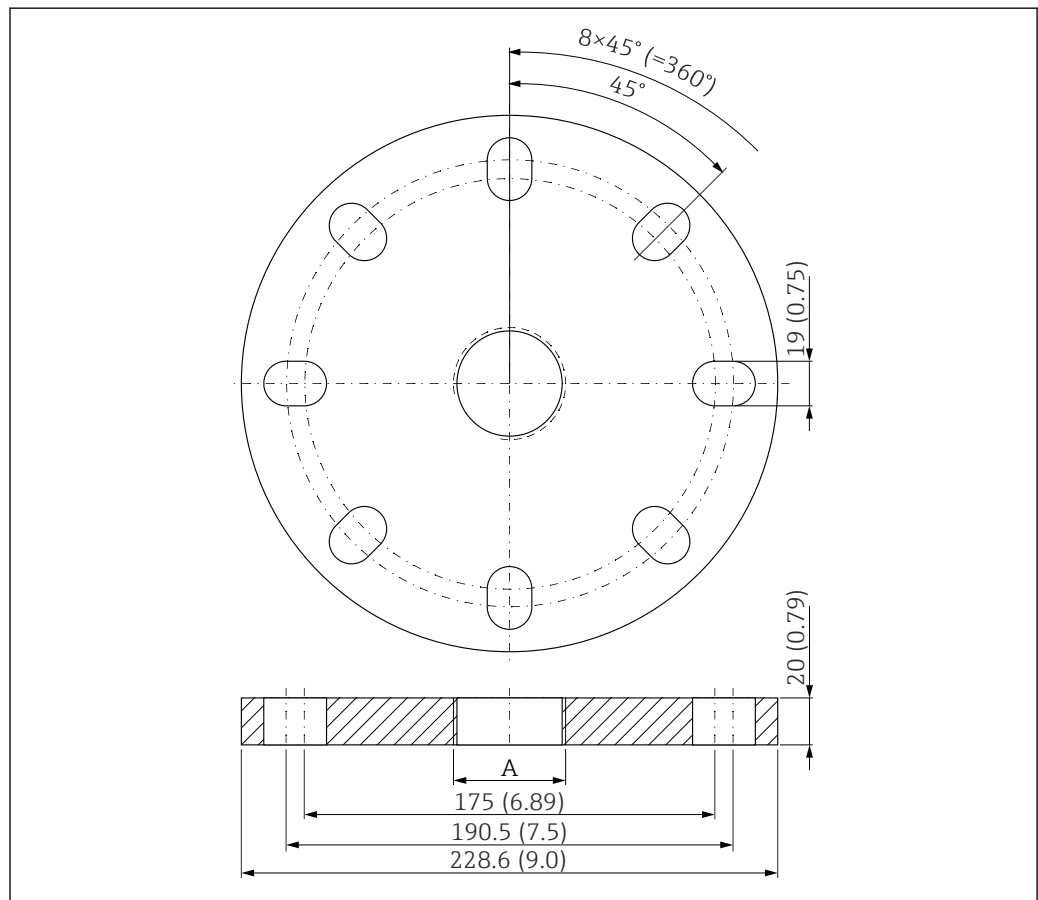

A0037948

39 Dimensions of UNI flange 4"/DN100/100, engineering unit: mm (in)

A Sensor connection in accordance with product structure "Process connection on rear"

**Material**

PP

**Order number**

FAX50-####

**Cantilever, pivotable**

*Sensor installation*

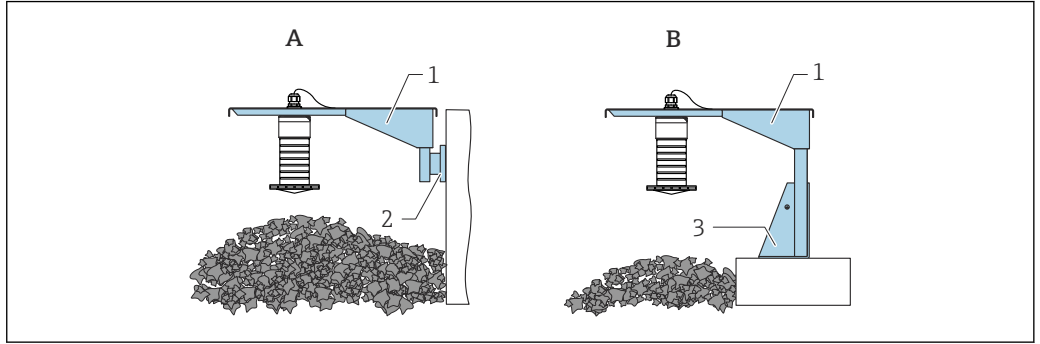

A0045347

40 Installation type sensor process connection rear side

- A Installation with cantilever and wall bracket
- B Installation with cantilever and mounting frame
- 1 Cantilever
- 2 Wall bracket
- 3 Mounting frame

*Cantilever arm 500 mm, for G 1" or MNPT 1" connections on rear*

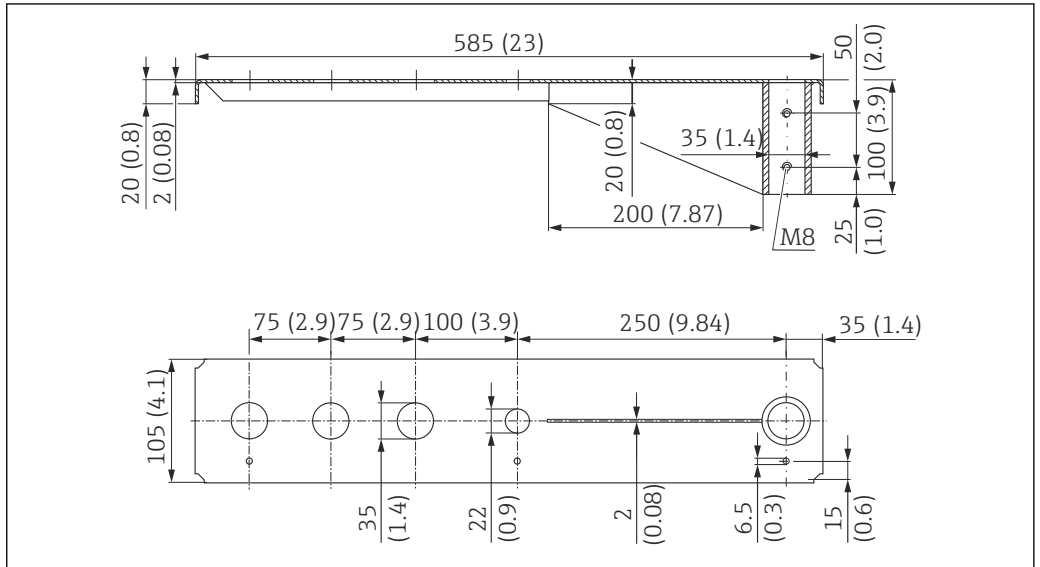

A0037806

41 Dimensions. Unit of measurement mm (in)

**Weight:**  
3.0 kg (6.62 lb)

**Material**  
316L (1.4404)

**Order number**  
71452315

- 35 mm (1.38 in) openings for all G 1" or MNPT 1" connections on rear
- 22 mm (0.87 in) opening can be used for any additional sensor
- Retaining screws are included in delivery

Cantilever arm 1 000 mm, for G 1" or MNPT 1" connections on rear

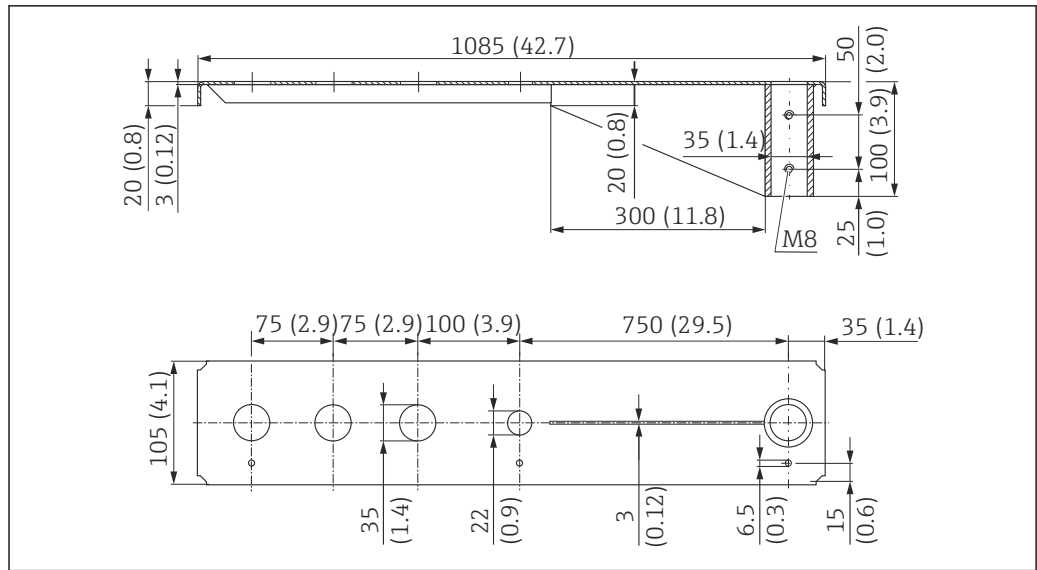

A0037807

42 Dimensions. Unit of measurement mm (in)

**Weight:**

5.4 kg (11.91 lb)

**Material**

316L (1.4404)

**Order number**

71452316

-  35 mm (1.38 in) openings for all G 1" or MNPT 1" connections on rear
- 22 mm (0.87 in) opening can be used for any additional sensor
- Retaining screws are included in delivery

Frame, 700 mm (27.6 in)

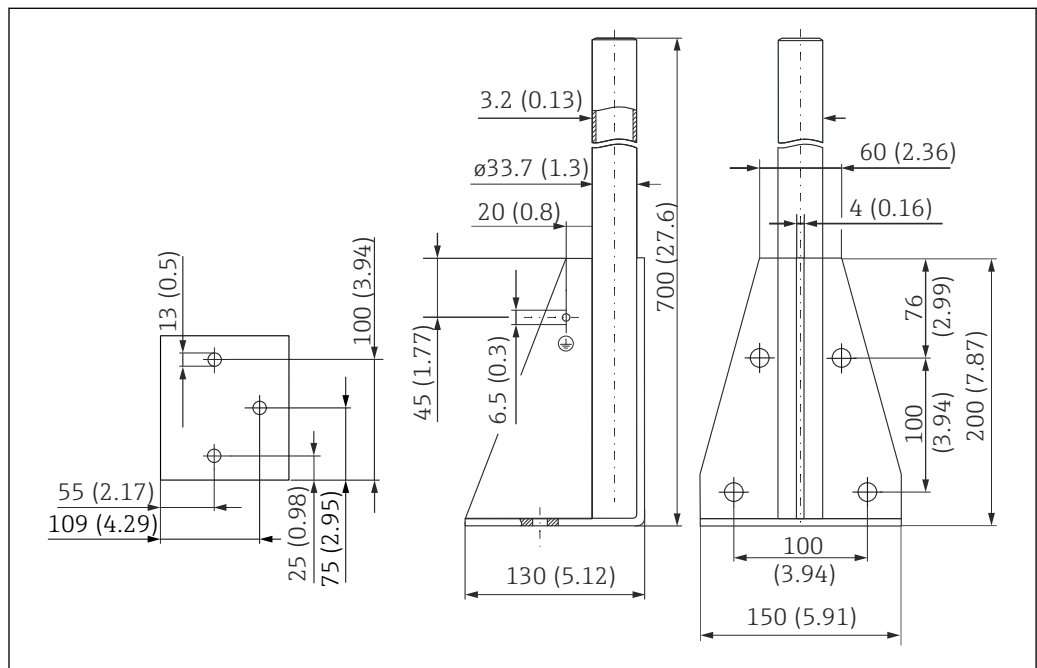

A0037799

43 Dimensions. Unit of measurement mm (in)



**Weight:**  
4.0 kg (8.82 lb)

**Material**  
316L (1.4404)

**Order number**  
71452327

Frame, 1400 mm (55.1 in)

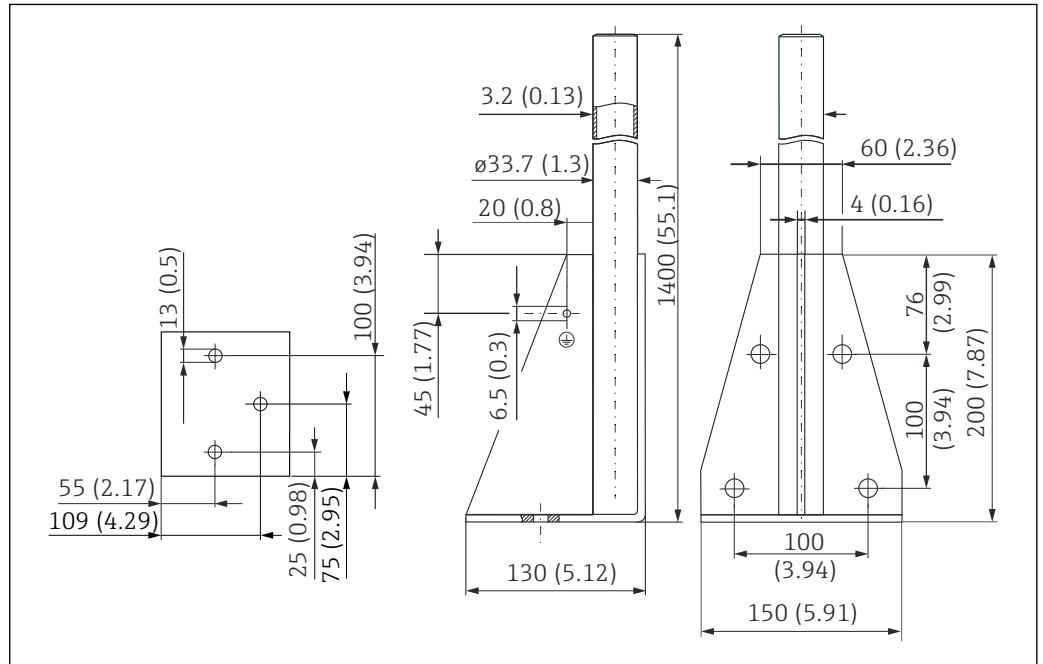

44 Dimensions. Unit of measurement mm (in)

**Weight:**  
6.0 kg (13.23 lb)

**Material**  
316L (1.4404)

**Order number**  
71452326

Wall bracket for cantilever with pivot

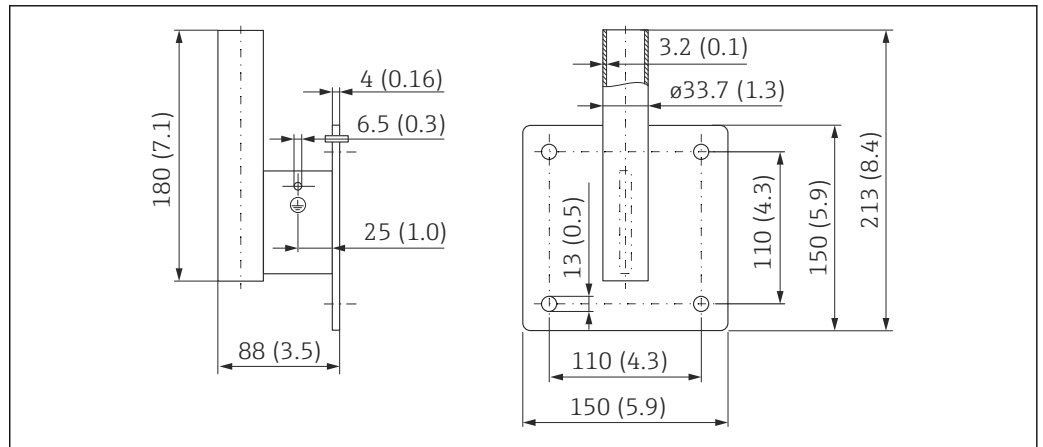

45 Dimensions of the wall bracket. Unit of measurement mm (in)

**Weight**

1.21 kg (2.67 lb)

**Material**

316L (1.4404)

**Order number**

71452323

**Ceiling mounting bracket**

The ceiling mounting bracket can be ordered together with the device via the product structure "Accessory enclosed".

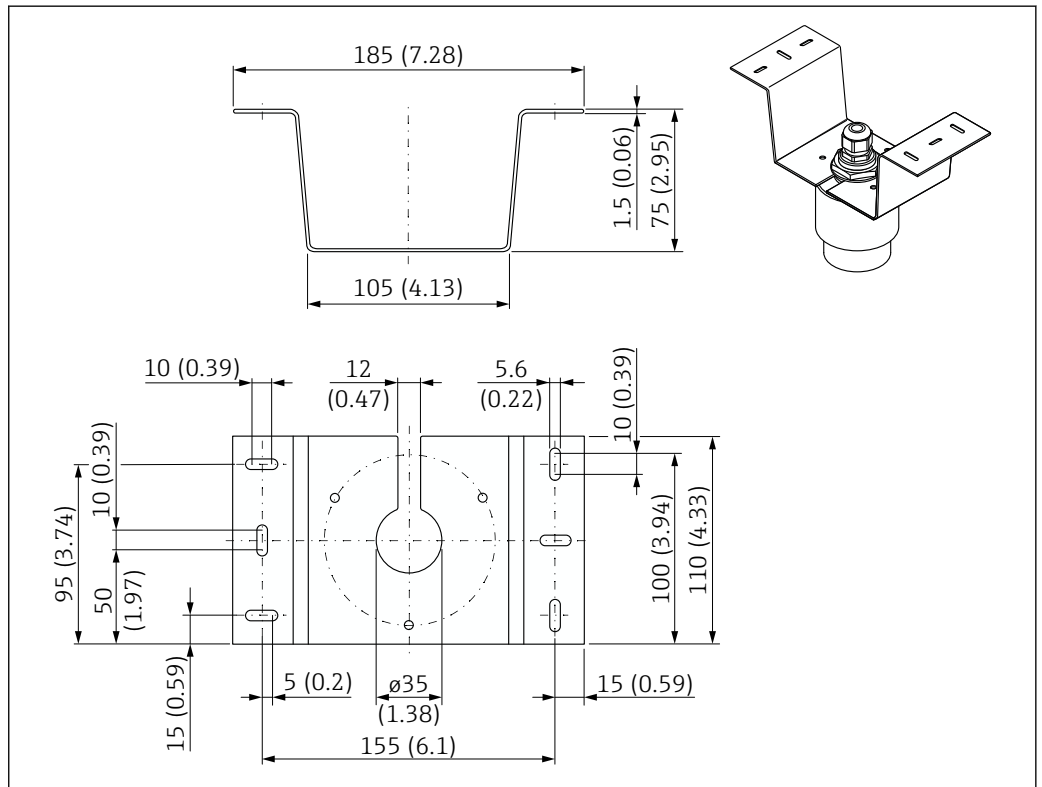

46 Dimensions of ceiling mounting bracket. Unit of measurement mm (in)

**Material**

316L (1.4404)

**Order number**

71093130

**Pivotable mounting bracket**

The mounting bracket can be ordered together with the device via the product structure "Accessory enclosed".

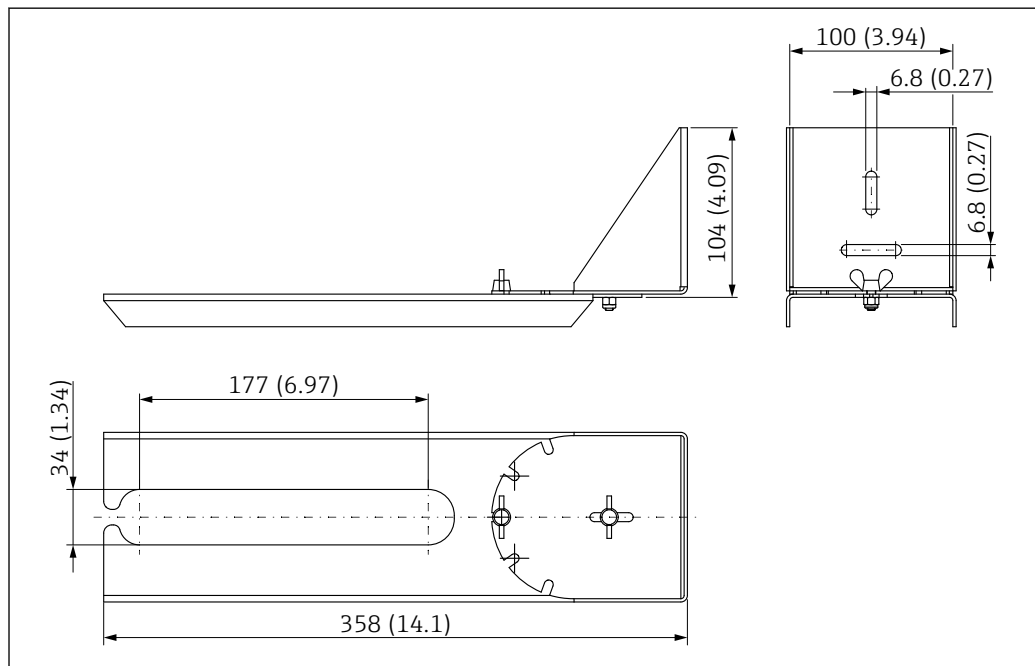

47 Dimensions of pivotable mounting bracket. Unit of measurement mm (in)

**Material**

316L (1.4404)

**Order number**

71429910

**Horizontal mounting bracket**

The horizontal mounting bracket is used to install the device in confined spaces.

The mounting bracket can be ordered together with the device via the product structure "Accessory enclosed".

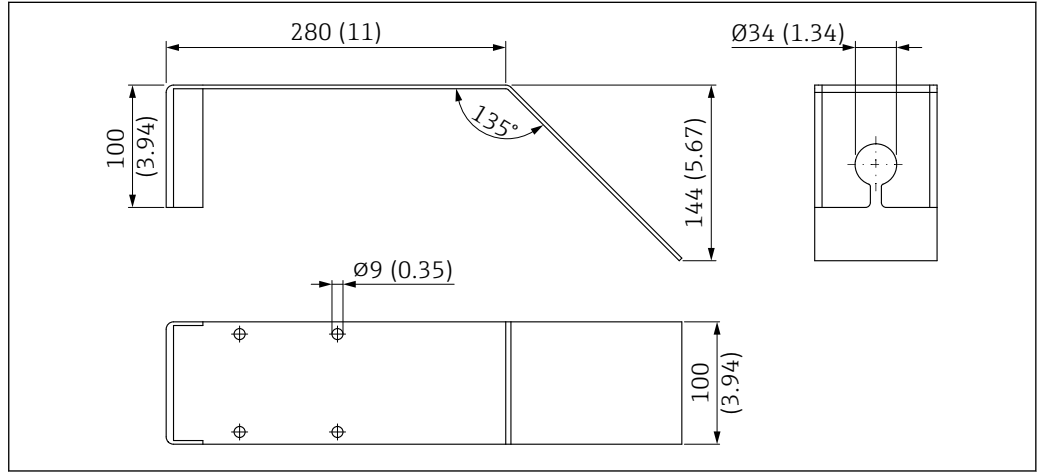

48 Dimensions of the horizontal mounting bracket. Unit of measurement mm (in)

**Material**

316L (1.4404)

**Order number**

71429905

### FAU40 alignment unit

The alignment unit is used to optimally align the sensor with the bulk solids.

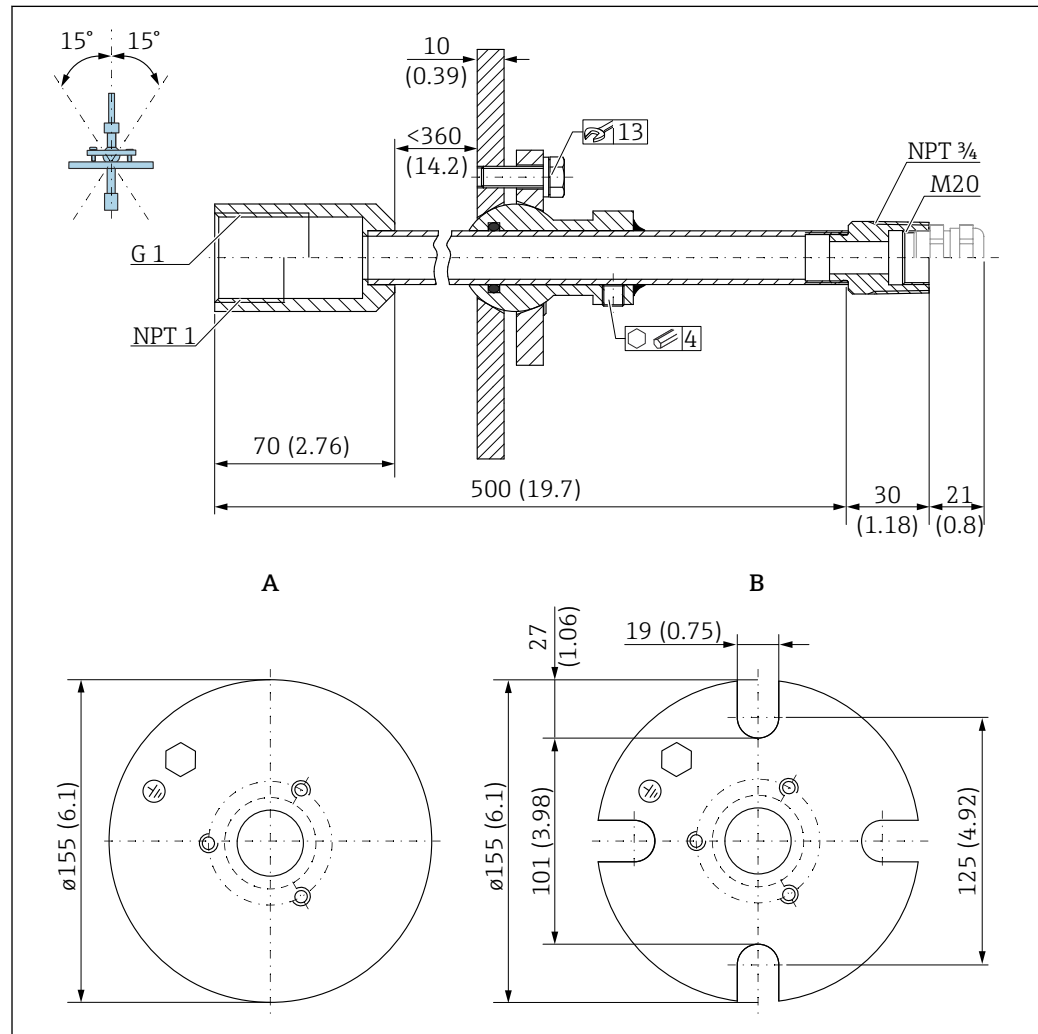

49 Dimensions. Unit of measurement mm (in)

- A Welding flange
- B UNI flange

### Material

- Flange: 304
- Pipe: steel, galvanized
- Cable gland: 304 or steel, galvanized

### Order number

FAU40-##

**i** Can be used for all rear sensor connections G1" or MNPT1, male thread, and connecting cable max.  $\varnothing 10$  mm (0.43 in), minimum length 600 mm (23.6 in).

**📖** Technical Information TI00179F

**Adjustable flange seal**

The adjustable flange seal is used to align the FMR20

The adjustable flange seal can be ordered together with the device via the product structure "Accessory enclosed".

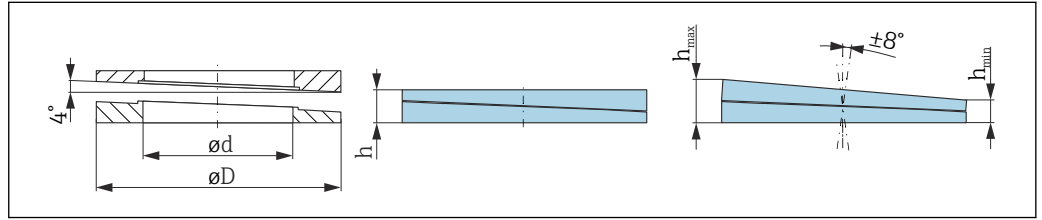

A0045324

50 Dimensions

Technical data: version DN/JIS			
Order number	71074263	71074264	71074265
Compatible with	DN80 PN10/40	DN100 PN10/16	<ul style="list-style-type: none"> <li>■ DN150 PN10/16</li> <li>■ JIS 10K 150A</li> </ul>
Recommended screw length	100 mm (3.9 in)	100 mm (3.9 in)	110 mm (4.3 in)
Recommended screw size	M14	M14	M18
Material	EPDM		
Process pressure	-0.1 to 0.1 bar (-1.45 to 1.45 psi)		
Process temperature	-40 to +80 °C (-40 to +176 °F)		
D	142 mm (5.59 in)	162 mm (6.38 in)	218 mm (8.58 in)
d	89 mm (3.5 in)	115 mm (4.53 in)	169 mm (6.65 in)
h	22 mm (0.87 in)	23.5 mm (0.93 in)	26.5 mm (1.04 in)
h <sub>min</sub>	14 mm (0.55 in)	14 mm (0.55 in)	14 mm (0.55 in)
h <sub>max</sub>	30 mm (1.18 in)	33 mm (1.3 in)	39 mm (1.45 in)
Technical data: version ASME/JIS			
Order number	71249070	71249072	71249073
Compatible with	<ul style="list-style-type: none"> <li>■ ASME 3" 150lbs</li> <li>■ JIS 80A 10K</li> </ul>	ASME 4" 150lbs	ASME 6" 150lbs
Recommended screw length	100 mm (3.9 in)	100 mm (3.9 in)	110 mm (4.3 in)
Recommended screw size	M14	M14	M18
Material	EPDM		
Process pressure	-0.1 to 0.1 bar (-1.45 to 1.45 psi)		
Process temperature	-40 to +80 °C (-40 to +176 °F)		
D	133 mm (5.2 in)	171 mm (6.7 in)	219 mm (8.6 in)
d	89 mm (3.5 in)	115 mm (4.53 in)	168 mm (6.6 in)
h	22 mm (0.87 in)	23.5 mm (0.93 in)	26.5 mm (1.04 in)
h <sub>min</sub>	14 mm (0.55 in)	14 mm (0.55 in)	14 mm (0.55 in)
h <sub>max</sub>	30 mm (1.18 in)	33 mm (1.3 in)	39 mm (1.45 in)

**Service-specific accessories****Applicator**

Software for selecting and sizing Endress+Hauser measuring devices:

- Calculation of all the necessary data for identifying the optimum measuring device: e.g. pressure loss, accuracy or process connections.
- Graphic illustration of the calculation results

Administration, documentation and access to all project-related data and parameters over the entire life cycle of a project.

Applicator is available:

<https://portal.endress.com/webapp/applicator>

**Configurator**

Product Configurator - the tool for individual product configuration

- Up-to-the-minute configuration data
- Depending on the device: Direct input of measuring point-specific information such as measuring range or operating language
- Automatic verification of exclusion criteria
- Automatic creation of the order code and its breakdown in PDF or Excel output format
- Ability to order directly in the Endress+Hauser Online Shop

The Configurator is available on the Endress+Hauser website: [www.endress.com](http://www.endress.com) -> Click "Corporate" -> Select your country -> Click "Products" -> Select the product using the filters and the search field -> Open the product page -> The "Configure" button to the right of the product image opens the Product Configurator.

**W@M**

Life cycle management for your plant

W@M supports you with a wide range of software applications over the entire process: from planning and procurement, to the installation, commissioning and operation of the measuring devices. All the relevant device information, such as the device status, spare parts and device-specific documentation, is available for every device over the entire life cycle.

The application already contains the data of your Endress+Hauser device. Endress+Hauser also takes care of maintaining and updating the data records.

W@M is available:

[www.endress.com/lifecyclemanagement](http://www.endress.com/lifecyclemanagement)

## Supplementary documentation

The following documentation types are available in the Downloads section of the Endress+Hauser website ([www.endress.com/downloads](http://www.endress.com/downloads)):

-  For an overview of the scope of the associated Technical Documentation, refer to the following:
  - *W@M Device Viewer* ([www.endress.com/deviceviewer](http://www.endress.com/deviceviewer)): Enter the serial number from nameplate
  - *Endress+Hauser Operations App*: Enter the serial number from the nameplate or scan the 2D matrix code (QR code) on the nameplate

**Brief Operating Instructions (KA)****Guide that takes you quickly to the 1st measured value**

The Brief Operating Instructions contain all the essential information from incoming acceptance to initial commissioning.

**Operating Instructions (BA)****Your reference guide**

These Operating Instructions contain all the information that is required in various phases of the life cycle of the device: from product identification, incoming acceptance and storage, to mounting, connection, operation and commissioning through to troubleshooting, maintenance and disposal.

**Safety Instructions (XA)**

Depending on the approval, the following Safety Instructions (XA) are supplied with the device. They are an integral part of the Operating Instructions.

-  The nameplate indicates the Safety Instructions (XA) that are relevant to the device.



## Registered trademarks

### **Modbus®**

Registered trademark of SCHNEIDER AUTOMATION, INC.

### **Apple®**

Apple, the Apple logo, iPhone, and iPod touch are trademarks of Apple Inc., registered in the U.S. and other countries. App Store is a service mark of Apple Inc.

### **Android®**

Android, Google Play and the Google Play logo are trademarks of Google Inc.

### **Bluetooth®**

The *Bluetooth*® word mark and logos are registered trademarks owned by the Bluetooth SIG, Inc. and any use of such marks by Endress+Hauser is under license. Other trademarks and trade names are those of their respective owners.

---

---



71535198

[www.addresses.endress.com](http://www.addresses.endress.com)

---